



PreciseFlex DD 6-Axis



PreciseFlex DD 4-Axis

PreciseFlexTM Direct Drive Robots

Service Manual

Part Number 628651, Revision A

Brooks Automation

Information provided within this document is subject to change without notice, and although believed to be accurate, Brooks Automation assumes no responsibility for any errors, omissions, or inaccuracies.

AcuLigner™, Advan Tag, AutoTeach™, ATR™, AXM™, BiSymmetrik™, CenterSmart™, Crate to Operate™, CrossingConnect™, DARTS™, Enerta™, e-RMA™, e-Spares™, e-Volution™, Falcon™, FIXLOAD™, FrogLeg™, GuardianPro™, Independent Twin Linear Exchange™, InCooler™, InLigner™, Isoport™, ITLX™, Jet™, Jet Engine™, LEAP™, LeapFrog™, LowProfile™, LPT™, M2 Nano™, Marathon 2, Marathon Express, PASIV™, Pathway™, PowerPak™, PowerTools™, PuroMaxx™, QuadraFly™, Radius™, Radiant™, Radiant Express™, Reliance™, Reliance ATR™, RetroEase™, SCARA™, SmartPM™, SMIF-INX™, SMIF-LPT™, SPOTLevel™, The New Pathway to Productivity™, Time Optimized Trajectory™, Time Optimal Trajectory™, Time Optimized Path™, TopCooler™, TopLigner™, VacuTran™, VersaPort™, WaferEngine™, LEAP™, Pathway™, GIO, GSB, Guidance 6600, Guidance 6430, Guidance 6420, Guidance 6410, Guidance 6000, Guidance 3400, Guidance 3300, Guidance 3200, Guidance 2600, Guidance 2400, Guidance 2300, Guidance 2200, Guidance 1400, Guidance 1300, Guidance 1200, Guidance 0200 Slave Amplifier, Guidance 0006, Guidance 0004, Guidance Controller, Guidance Development Environment, GDE, Guidance Development Suite, GDS, Guidance Dispense, Guidance Input and Output Module, Guidance Programming Language, GPL, Guidance Slave Board, Guidance System, Guidance System D4/D6, IntelliGuide, PreciseFlex™ 100, PreciseFlex™ 300, PreciseFlex™ 400, PreciseFlex™ 3400, PreciseFlex™ c3, PreciseFlex™ c5, PreciseFlex™ c8a™, PreciseFlex™ c10™, PreciseFlex™ 1300, PreciseFlex™ 1400, PreciseFlex™ DD4, PreciseFlex™ DD6, PreciseFlex™ DDR, PreciseFlex™ G5400, PreciseFlex™ G5600, PreciseFlex™ G6400, PreciseFlex™ G6410, PreciseFlex™ G6420, PreciseFlex™ G6430, PreciseFlex™ G6600, PreciseFlex™ GSB Slave Amp, PreciseFlex™ PFD0, PrecisePlace 100, PrecisePlace 0120, PrecisePlace 0130, PrecisePlace 0140, PrecisePlace 1300, PrecisePlace 1400, PrecisePlace 2300, PrecisePlace 2400, PrecisePower 300, PrecisePower 500, PrecisePower 1000, PrecisePower 2000, PreciseVision, IntelliGuide Vision, and RIO logos are trademarks of Brooks Automation.

Fusion®, Guardian®, MagnaTran®, Marathon®, Razor®, Spartan®, Vision®, Zaris®, and the Brooks and design logo are registered U.S. trademarks of Brooks Automation.

All other trademarks are properties of their respective owners.

© 2025 Brooks Automation. All rights reserved. The information included in this manual is proprietary information of Brooks Automation, and is provided for the use of Brooks customers only and cannot be used for distribution, reproduction, or sale without the express written permission of Brooks Automation.

This technology is subject to United States export Administration Regulations and authorized to the destination only; diversion contrary to U.S. law is prohibited.

<p>Brooks Automation 15 Elizabeth Drive Chelmsford, MA 01824-2400 Tel: +1 978-262-2400 Fax: +1 978-262-2500</p>	<p>Brooks Automation, PreciseFlex Collaborative Robots 201 Lindbergh Avenue Livermore, CA 94551 Tel: +1-408-224-2838</p>
--	---



Worldwide Headquarters

15 Elizabeth Drive
Chelmsford, MA 01824 U.S.A.

**Brooks Automation,
PreciseFlex Collaborative Robots**

201 Lindbergh Avenue
Livermore, CA 94551 U.S.A

Technical Support

Location	Contact	Website
North America	+1-800-447-5007 (Toll-Free) +1-978-262-2900 (Local) +1-408-224-2838 (PreciseFlex)	http://www.brooks.com/
Europe	support_preciseflex@brooksautomation.com	
Japan	+81 120-255-390 (Toll Free) +81 45-330-9005 (Local)	
China	+86 21-5131-7066	
Taiwan	+886 080-003-5556 (Toll Free) +886 3-5525258 (Local)	
Korea	1800-5116 (Toll Free)	
Singapore	+65 1-800-4-276657 (Toll Free) +65 6309 0701 (Local)	

General Emails

Division	Email Address
Sales	sales_preciseflex@brooksautomation.com
Technical Support	support_preciseflex@brooksautomation.com
Technical Publications	Technical.Publications@brooksautomation.com



Brooks Automation

15 Elizabeth Drive
Chelmsford, MA
01824-2400
Tel: +1 978-262-2400
Fax: +1 978-262-2500
www.brooks.com

Brooks Locations Worldwide:

Brooks Automation
46702 Bayside Parkway
Fremont, CA 94538
Tel: +1-510-661-5000
Fax: +1-510-661-5166

Brooks Automation
AIM Servicios Administrativos
S de RL de CV
Carretera Huinalá km 2.8
Parque Industrial Las Américas
66640 Apodaca, NL Mexico
Tel: +52 81 8863-6363

**Brooks Automation
(Germany) GmbH**
Ernst-Ruska-Ring 11
07745 Jena, Germany
Tel: +49 3641 4821 100
Fax: +49 3641 4821 4100

**Brooks Automation
(Germany) GmbH**
Daimler-Straße 7
78256 Steißlingen, Germany
Tel: +49-7732-9409-0
Fax: +49-7732-9409-200

Brooks Automation
9601 Dessau Road, Suite 301
Austin, TX 78754
Tel: +1 512-912-2840
Toll-Free: +1 800-367-4887

**Brooks Automation
(Israel) Ltd.**
Mevo Yerach 5
Kiryat-Gat 82000
Israel
Tel: +972 8672 2988
Fax: +972 8672 2966

**Brooks Technology (Shanghai)
Limited**
2nd Floor, No. 72,
887 Zuchongzhi Road
Zhangjiang Hi-Tech
Park Pudong, Shanghai
China 201203
Tel: +86-21-5131-7070
Fax: +86-21-5131-7068

Brooks Japan K.K.
HEADQUARTERS
Nisso Bldg, No 16, 9F
3-8-8 ShinYokohama, Kohoku-ku
Yokohama, Kanagawa 222-0033
Tel: +81-45-477-5570
Fax: +81-45-477-5571

Brooks Japan K.K.
YOKOHAMA TECHNICAL
CENTER
852-1 Kawamuko-cho, Tsuzuki-ku
Yokohama, Kanagawa 224-0044
Tel: +81-45-477-5250
Fax: +81-45-470-6800

Brooks Japan K.K.
KUMAMOTO SERVICE OFFICE
202 Mirai Office II
312-1 Tatsudamachi Yuge
Tatsuda, Kumamoto 861-8002
Tel: +81-96-327-9720
Fax: +81-96-327-9721

Brooks CCS Japan K.K.
CONTAMINATION CONTROL
SOLUTIONS
Nisso Bldg, No 16, 9F
3-8-8 ShinYokohama, Kohoku-ku
Yokohama, Kanagawa 222-0033
Tel: +81-45-477-5570
Fax: +81-45-477-5571

Brooks Automation Ltd.
TAIWANHEADQUARTERS
5F-5, No.32, Tai-Yuen Street
Chu-Pei City
Hsinchu County 302, Taiwan,
R.O.C.
Tel: +886-3-552 5258
Fax (G&A): +886-3-552 5255
Fax (Sales): +886-3-552 5200

Brooks Automation Korea, Inc.
#35 Giheungdanji-Ro 121Beon-
Gil
Giheung-Gu, Yongin-Si
Gyeonggi-Do, 17086
Korea
Tel: +82-31-288-2500
Fax: +82-31-287-2111

**Brooks Automation CCS RS
AG**
Lohstampfstrasse 11
CH-8274 Tagerwilen, Switzerland
Tel: + 41 71-666-72-10
Fax: + 41 71-666-72-11

Brooks Automation Korea
#35 Giheungdanji-Ro 121Beon-
Gil
Giheung-Gu, Yongin-Si
Gyeonggi-Do, 17086
Korea
Tel: +82-31-288-2500
Fax: +82-31-287-2111

Brooks Automation (S) Pte Ltd
51-18-C1 Menara BHL,
57 Jalan Ahmad Shah,
10050, Penang,
Malaysia
Tel: +60 4 3701012
Fax: +60 4 3701015

**Brooks Automation
(Singapore) Pte Ltd**
Blk 5008 Ang Mo Kio Avenue 5
#05-08, Techplace II
Singapore 569874
Tel: +65-6836-3168
Fax: +65-6836-3177

Brooks Automation Ltd.
TAINAN OFFICE
3F., No.11, Nanke 3rd Rd., Xinshi
Dist.
Tainan Science Park
Tainan City 74147, Taiwan
(R.O.C.)
TEL: +886-6-505-0268
FAX: +886-6-505-5228

**Brooks Automation
Precise Collaborative Robotics**
201 Lindbergh Drive
Livermore, CA 94551
Tel: +1-978-262-2400

PreciseFlex DD Service Manual Revision History

Revision	ECO	Date	Action	Author
A	EC154071	4/19/2024	Released manual at Rev. A to follow standard Brooks technical publication styles.	M. Ashenfelder

Table of Contents



1. Safety	1
Safety Setup	1
Explanation of Hazards and Alerts	1
Safety Text	1
Safety Icons	2
Signal Words and Colors	2
Alert Example	3
General Safety Considerations	4
Electrical Hazards	6
Ergonomic Hazards	8
Emergency Stop Circuit (E-Stop)	9
Recycling and Hazardous Materials	9
2. Service Procedures	10
Recommended Tools	10
Troubleshooting	10
Encoder Operation Error	12
Replacing the Encoder Batteries	14
Calibrating the Robot: Setting the Encoder Zero Positions	17
Replacing Belts and Motors	22
General Belt Tensioning	22
Tensioning or Replacing the J2 (Z Column) Belts	22
Tensioning the 1st Stage Belt	22
Tensioning the 2nd Stage Belt	23
Replacing the Z column Stage One Timing Belt	25
Replacing the Z Column Stage Two Timing Belt	26
Tensioning or Replacing the Belts in the PFDD4	28
Tensioning the Belts in the PFDD4 Outer Link	28
Replacing the Belts in the PFDD4 Outer Link	29
Replacing the Robot Main Controller	30
Replacing the Z-axis Slave Controller	32
Replacing the J3 Axis Slave Controller	34
Replacing the J4 or Gripper Slave Controller in PFDD4	36
Replacing the Gripper and Slip Ring in PFDD4	38
Replacing the Main Harness	41
Replacing the J3 Clock Spring Harness to the J4 Motor	41
Replacing the J4 to Gripper Controller Harness in the PFDD4	43
Replacing the J4 slave controller in the PFDD6	44
Replacing the J4 to J5 or J5 to J6 Controller Harness, J5 or J6 slave controller in the PFDD6	45
Replacing the J6 Motor Pigtail Harness	49
Appendices	51
Appendix A: Conditions of Acceptability	52
Appendix B: DD6 Product Specifications	53
Appendix C: DD4 Product Specifications	55

Appendix D: Environmental Specifications	57
Appendix E: Spare Parts List	58
Appendix F: Preventative Maintenance	60
Appendix G: Belt Tensions, Gates Tension Meter	61
Appendix H: System Diagram and Power Supplies	63
Appendix I: Safety Circuits for PFDD Robots	82
Appendix J: Example Performance Level Evaluation for the PFDD	84
Appendix K: Table A2 from ISO/TS 15066: 2016	85
Appendix L: ISO TS 15066 Test Results, Transient Contact	87
Appendix M: ISO TS 15066 Test Results, Quasi-Static Contact	88
Appendix N: Comparison of Plastic and Foam Covers	90
Impact Force	90
Arm Dimensions	92
Appendix O: Torque Values for Screws	94

1. Safety

Safety Setup

Brooks uses caution, warning, and danger labels to convey critical information required for the safe and proper operation of the hardware and software. Read and comply with all labels to prevent personal injury and damage to the equipment.

 DANGER Read the Safety Chapter	
<p>Failure to review the <i>Safety</i> chapter and follow the safety warnings can result in serious injury or death.</p> <ul style="list-style-type: none">• All personnel involved with the operation or maintenance of this product must read and understand the information in this safety chapter.• Follow all applicable safety codes of the facility as well as national and international safety codes.• Know the facility safety procedures, safety equipment, and contact information.• Read and understand each procedure before performing it.	

Explanation of Hazards and Alerts

This manual and this product use industry standard hazard alerts to notify the user of personal or equipment safety hazards. Hazard alerts contain safety text, icons, signal words, and colors.

Safety Text



Hazard alert text follows a standard, fixed-order, three-part format.

- Identify the hazard
- State the consequences if the hazard is not avoided

- State how to avoid the hazard.

Safety Icons



- Hazard alerts contain safety icons that graphically identify the hazard.
- The safety icons in this manual conform to [ISO 3864-1:2011](#) *Graphical symbols — Safety colours and safety signs* and [ANSI Z535](#) standards.

Safety Icon Examples	
	Warning
	Two-Person Lift
	Electric Shock

Signal Words and Colors

Signal words and colors inform of the level of hazard.

	<p>Danger indicates a hazardous situation which, if not avoided, will result in serious injury or death.</p> <p>The Danger signal word is white on a red background with an exclamation point inside a yellow triangle with black border.</p>
---	--

	<p>Warning indicates a hazardous situation which, if not avoided, could result in serious injury or death.</p> <p>The Warning signal word is black on an orange background with an exclamation point inside a yellow triangle with black border.</p>
	<p>Caution indicates a hazardous situation or unsafe practice which, if not avoided, may result in minor or moderate personal injury.</p> <p>The Caution signal word is black on a yellow background with an exclamation point inside a yellow triangle with black border.</p>
	<p>Notice indicates a situation or unsafe practice which, if not avoided, may result in equipment damage.</p> <p>The Notice signal word is white on blue background with no icon.</p>

Alert Example

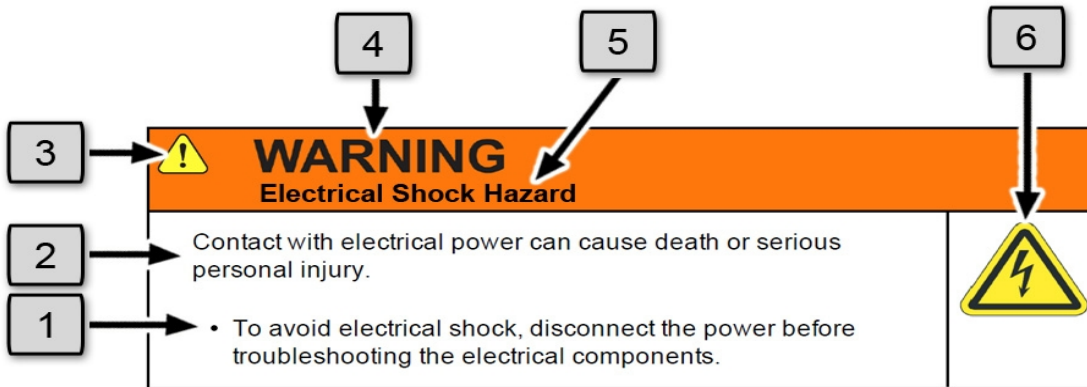

The following is an example of a Warning hazard alert.







Number	Description
1.	How to Avoid the Hazard
2.	Source of Hazard and Severity
3.	General Alert Icon



Number	Description
4.	Signal Word
5.	Type of Hazard
6.	Hazard Symbol(s)



General Safety Considerations



 WARNING Software	
<p>Software is not safety rated. Unplanned motion can occur as long as power is supplied to the motors. Maximum torque could be momentarily applied that may cause equipment damage or personal injury.</p> <ul style="list-style-type: none">• Only operate the robot with its covers installed.• Guarantee that safety controller features are in place (for example, an emergency stop button and protective stop).• Regularly test safety components to prove that they function correctly.	 



 WARNING Robot Mounting	
<p>Before applying power, the robot must be mounted on a rigid test stand, secure surface, or system application. Improperly mounted robots can cause excessive vibration and uncontrolled movement that may cause equipment damage or personal injury.</p> <ul style="list-style-type: none">• Always mount the robot on a secure test stand, surface, or system before applying power.	



 WARNING Do Not Use Unauthorized Parts	
<p>Using parts with different inertial properties with the same robot application can cause the robot's performance to decrease and potentially cause unplanned robot motion that could result in serious personal injury.</p> <ul style="list-style-type: none"> Do not use unauthorized parts. Confirm that the correct robot application is being used. 	

 WARNING Magnetic Field Hazard	
<p>This product contains magnetic motors that can be hazardous to implanted medical devices, such as pacemakers, and cause personal harm, severe injury, or death.</p> <ul style="list-style-type: none"> Maintain a safe working distance of 30 cm from the motor when with an energized robot if you use a cardiac rhythm management device. 	

 CAUTION Unauthorized Service	
<p>Personal injury or damage to equipment may result if this product is operated or serviced by untrained or unauthorized personnel.</p> <ul style="list-style-type: none"> Only qualified personnel who have received certified training and have the proper job qualifications are allowed to transport, assemble, operate, or maintain the product. 	



 CAUTION Damaged Components	
<p>The use of this product when components or cables appear to be damaged may cause equipment malfunction or personal injury.</p> <ul style="list-style-type: none">• Do not use this product if components or cables appear to be damaged.• Place the product in a location where it will not get damaged.• Route cables and tubing so that they do not become damaged and do not present a personal safety hazard.	



 CAUTION Inappropriate Use	
<p>Use of this product in a manner or for purposes other than for what it is intended may cause equipment damage or personal injury.</p> <ul style="list-style-type: none">• Only use the product for its intended application.• Do not modify this product beyond its original design.• Always operate this product with the covers in place.	



 CAUTION Seismic Restraint	
<p>The use of this product in an earthquake-prone environment may cause equipment damage or personal injury.</p> <ul style="list-style-type: none">• The user is responsible for determining whether the product is used in an earthquake prone environment and installing the appropriate seismic restraints in accordance with local regulations.	

Electrical Hazards

Refer to the specifications of the *Guidance Controller Quick Start Guide* for the electrical power.

 DANGER Electrical Shock Hazard	
<p>Contact with electrical power can cause personal harm and serious injury.</p> <ul style="list-style-type: none">• To avoid electrical shock, disconnect the power before troubleshooting the electrical components.• Check the unit's specifications for the actual system power requirements and use appropriate precautions.• Never operate this product without its protection covers on.	

 WARNING Electrical Burn	
<p>Improper electrical connection or connection to an improper electrical supply can result in electrical burns resulting in equipment damage, serious injury, or death.</p> <ul style="list-style-type: none">• Always provide the robot with the proper power supply connectors and ground that are compliant with appropriate electrical codes.	



 WARNING Electrical Fire Hazard	
<p>All energized electrical equipment poses the risk of fire, which may result in severe injury or death. Fires in wiring, fuse boxes, energized electrical equipment, computers, and other electrical sources require a Class C extinguisher.</p> <ul style="list-style-type: none">• Use a fire extinguisher designed for electrical fires (Class C in the US and Class E in Asia).• It is the facility's responsibility to determine if any other fire extinguishers are needed for the system that the robot is in.	



NOTICE



Improper handling of the power source or connecting devices may cause component damage or equipment fire.

- Connect the system to an appropriate electrical supply.
- Turn off the power before servicing the unit.
- Turn off the power before disconnecting the cables.

Ergonomic Hazards



 CAUTION Heavy Lift Hazard	
<p>Failure to take the proper precautions before moving the robot could result in back injury and muscle strain.</p> <ul style="list-style-type: none">• Use a lifting device and cart rated for the weight of the drive or arm.• Only persons certified in operating the lifting device should be moving the product.	

 CAUTION Tipover Hazard	
<p>This product has a high center of gravity which may cause the product to tip over and cause serious injury.</p> <ul style="list-style-type: none">• Always properly restrain the product when moving it.• Never operate the robot unless it is rigidly mounted.	

 CAUTION Trip Hazard	
<p>Cables for power and communication and facilities create trip hazards which may cause serious injury.</p> <ul style="list-style-type: none"> • Always route the cables where they are not in the way of traffic. 	

Emergency Stop Circuit (E-Stop)

The integrator of the robot must provide an external emergency stop switch.

 WARNING Emergency Stop Circuit	
<p>Using this product without an emergency stop circuit may cause personal injury.</p> <ul style="list-style-type: none"> • Customer is responsible for integrating an emergency stop circuit into their system. • Do not override or bypass the emergency stop circuit. 	

Recycling and Hazardous Materials

Brooks Automation complies with the EU Directive 2002/96/EU Waste Electrical and Electronic Equipment (WEEE).

The end user must responsibly dispose of the product and its components when disposal is required. The initial cost of the equipment does not include the cost of disposal. For further information and assistance in disposal, email Brooks Automation Technical Support at support_preciseflex@brooksautomation.com.

2. Service Procedures

Recommended Tools

The following tools are recommended for these service procedures:

1. Gates Sonic Belt Tension Meter, Model 507C for checking timing belt tension
2. A set of metric “stubby” hex L-keys, for example McMaster Carr PN 6112A21 with 1.5, 2.0, 2.5, 3.0, 4, 5, and 6 mm L Keys
3. A set of metric hex drivers including 1.27, 1.5, 2.0, 2.5 and 3.0 mm driver, for example McMaster Carr PN 52975A21
4. Metric ball end hex drivers, 4.0 mm and 5.0 mm for M5 and M6 SHCS
5. A pair of tweezers or needle nose pliers
6. A pair of side angle cutters
7. Small flat bladed screwdriver, with 1.5 mm wide blade typical

Troubleshooting

PreciseFlex robots and controllers have an extensive list of error messages. Refer to the HTML document *PreciseFlex Library* to search for a specific error message and cause. Listed below in [Table 2-1](#) are a few errors that may be generated by hardware failures.

Table 2-1: Hardware Failure Errors

Symptom	Recommended Action
System error message generated	
E-Stop not Enabled	Check 9 pin Dsub for Estop jumpers.
Encoder Battery Low”	Replace absolute encoder battery on back of column or outer link.
Encoder Battery Down	If encoder cable has been disconnected, recalibrate robot. If battery voltage has dropped below 2.5V replace encoder battery and recalibrate robot.

Symptom	Recommended Action
Encoder Operation Error	Joint rotated too quickly with power off. See "Encoder Operation Error" on page 1.
Encoder Data, Accel/decel Limit Error	Encoder cable may be damaged and encoder is getting intermittent communication, causing apparent jumps in position. Check encoder connectors. Replace motor/encoder or encoder only on DD axes.
Encoder Communication Error	Check encoder connectors. Replace encoder cable or motor/encoder.
Encoder quadrature error	Replace slip ring. Replace motor/encoder (only Gripper motor).
Missing zero index	See Encoder quadrature error.
Motor duty cycle exceeded	Reduce speed or acceleration of robot. Check for instability.
Amplifier under voltage	Motor power supply has reached current limit and shutdown. Slow down the robot. Check the Energy Dump PCA. Replace the 48V supply.
Amplifier Fault	Check harness and motor for shorts.
Amplifier Over Voltage	Check energy dump resistor is connected. Check harness for shorts.
Soft Envelope Error	Make sure robot not pressing against surface. If this occurs on the gripper repeatedly, replace slip ring.
Hard Envelope Error	Typically means robot has crashed into something.
Pneumatic Gripper Sensor not working	Check continuity of cable through wrist. Check green lights on sensor to see if sensor is triggering.
Time Out Nulling Error	Check that joint is free to move with brake off. Check that joint is not vibrating or unstable. If unstable check belt tension. If Gripper, check for free motion, if OK replace slip ring.
Joint Out of Range	The joint actual or commanded position may be beyond the software limit stop. Move joint back into range while monitoring virtual pendant or check program for commanded position.
PAC Files Corrupted	See "Recovering from Corrupted PAC Files" on page 1.
Physical or audible problem	
Brown streaks on linear bearing	Clean with alcohol and add grease to bearing blocks. This should not be required sooner than 20,000 hours of run time. Grease is Alvania Grease EP2 from Shell.
Mechanical noise from any joint	Check joint bearings for failure. Re-tension the belt.
Loud buzzing or vibration from any joint	Re-tension the timing belts. If the timing belt will not hold tension, replace it.
Squeaking from Z belt	Apply thick grease to front and rear edges of belt, (Mobile 222 XP). Belt can get stiff over time and squeak against pulley flanges.

Encoder Operation Error

The PFDD robots are equipped with absolute encoders that keep track of the robot position even when AC power to the robot is disconnected. **There are batteries in the back of the Z column of the robot and outer link that provides standby power to the encoders for the Z axis and outer link motors. J1 and J3 axes have single turn absolute encoders and do not require standby batteries.** In standby mode, there is a limit on how quickly the motor can turn and still have the standby counter operate properly. The limits are 6,000 rpm and 4000 rad/s². Even at 100% speeds the robot joints normally do not move faster than about 2,000 rpm and 1300 rad/s². However, if the robot is shocked during shipping, it is possible the standby operation acceleration error limit may be exceeded. This can generate an encoder operation error that will prevent the robot from homing after power up.

This error will be displayed in the Operator Window of the Web Interface as “Encoder Operation Error” Robot 1: <axis number>.

Assuming the robot has not been damaged by the shipping process, reset this error by performing the procedure in [Table 2-2](#):

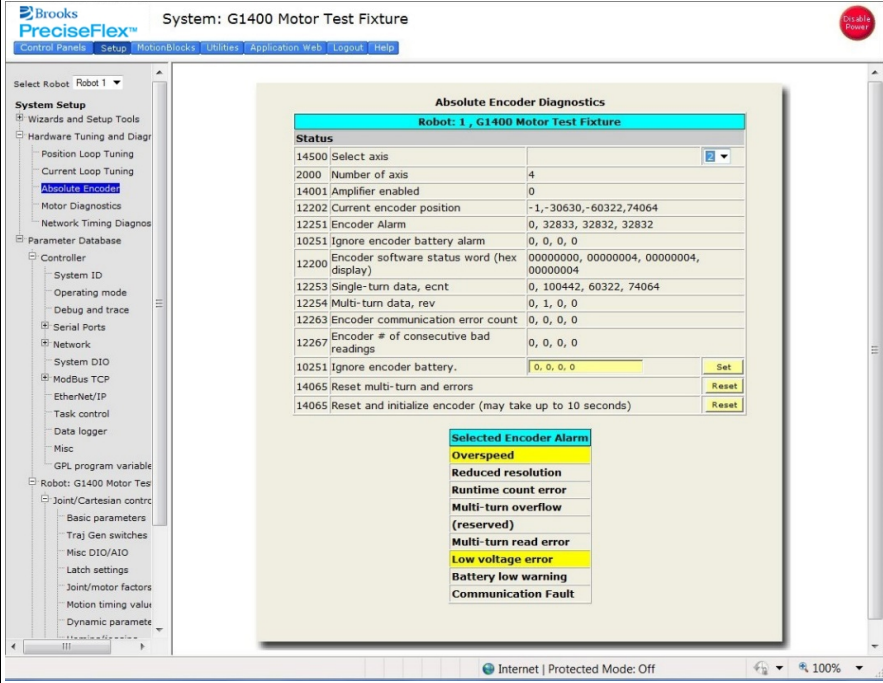

Table 2-2: Resetting the Error

Step	Action
1.	Access the Web Operator Interface to the robot with either “Maintenance” or “Administrator” privileges.

Step	Action
2.	<p>In the “Setup” menu, select “Hardware Tuning and Diagnostics”, then select “Absolute Encoder”. A screen similar to that shown below should display.</p> 
3.	<p>In the drop-down menu at the top right of the screen, select the robot axis that was associated with the error and check to see if the Overspeed panel is yellow. This indicates an overspeed error during encoder standby mode due to shock or vibration. This error can be reset by selecting the reset button next to “Reset and initialize encoder.” This button resets error flags, but does NOT reset the encoder counters. The robot can then be homed normally.</p>
4.	<p>For cases where the encoder operation error was triggered by shipping vibration, IN MOST CASES the encoder will not have lost any position data. However, after homing the robot it is a good idea to move the robot to the calibration position (using the calibration pins if desired-see Calibrating the Robot), or another known position, and check the joint angles in the Virtual Pendant in the Web Operator Interface. See the Calibration Procedure in Calibrating the Robot: Setting the Encoder Zero Positions for the joint angles in the Calibration Position.</p>

If the robot joints after this procedure followed by homing are different from the above, then the robot needs to be re-calibrated. See the procedure in [Calibrating the Robot: Setting the Encoder Zero Positions](#).

Replacing the Encoder Batteries

 DANGER Electrical Shock	
<p>Before replacing the encoder battery, the AC power should be disconnected. Removing the front cover allows access to the AC power terminals.</p>	

The Encoder Batteries are designed to last for several years with robot power off. With robot power on, there is no drain on the battery. The battery voltage is monitored by the system. The nominal battery voltage is 3.6 Volts. If the battery voltage drops to 3.3 Volts an error message “Encoder Battery Low” is generated. At this level the absolute encoder backup function will still work, however the Battery should be replaced. If the voltage drops to 2.5 Volts, an error message “Absolute Encoder Down” is generated. At this point, the absolute encoder backup function will not work.

Note that if any motor/encoder is disconnected from the encoder battery by disconnecting the encoder cable, the “Encoder Battery Low” or Encoder Battery Down” message will be generated. However, in this case the encoder battery does not need to be replaced. It is only necessary to re-calibrate the robot (see [Calibrating the Robot: Setting the Encoder Zero Positions](#)). See the battery locations in [Figure 2-1](#), [Figure 2-2](#), and [Figure 2-3](#).

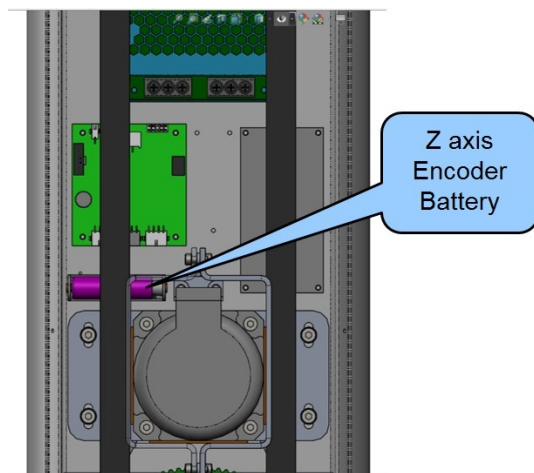

Figure 2-1: Location of the Z Axis Encoder Battery

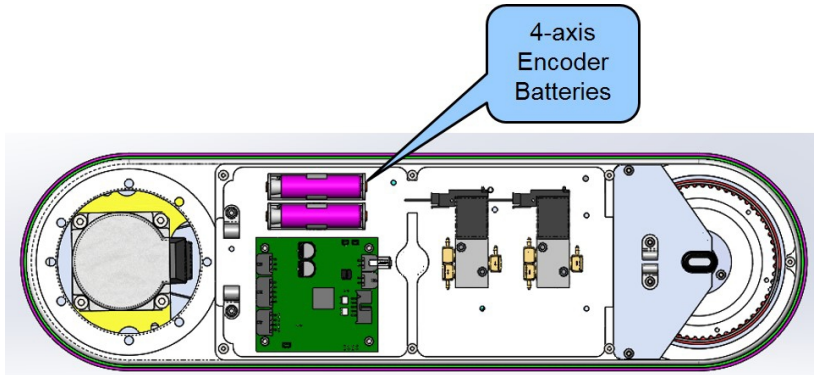

Figure 2-2: Location of the Four-Axis Encoder Batteries

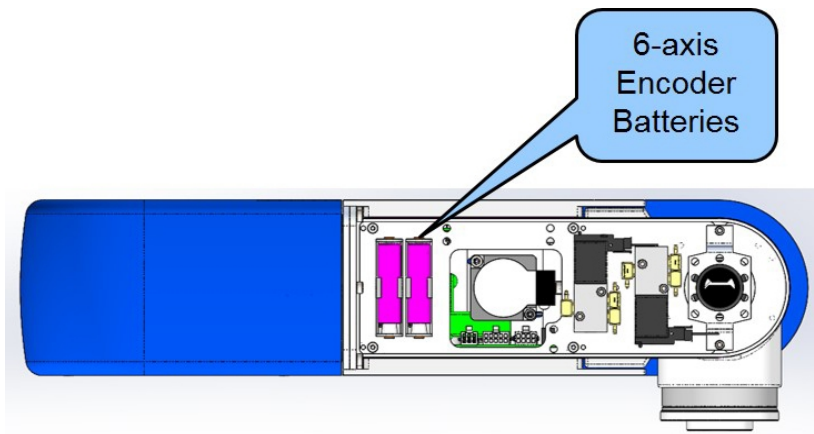

Figure 2-3: Location of the Six-Axis Encoder Batteries

Tools Required

- 2.0mm hex driver or hex L wrench

Parts Required

- New Encoder Battery PN G1S0-EC-X0007

To replace the Encoder Battery for the Z axis, perform the procedure shown in [Table 2-3](#):

Table 2-3: Replacing the Encoder Battery for the Z Axis

Step	Action
1.	Turn off power to the robot and remove the AC power plug.
2.	Remove the curved back cover from the Z column.
3.	Replace the battery.
4.	Replace the curved back cover on the Z column.

To replace the Encoder Battery in the four-axis outer link, perform the procedure in [Table 2-4](#):

Table 2-4: Replacing the Encoder Battery in the Four-Axis Outer Link

Step	Action
1.	Remove the outer link foam cover from the sides of the outer link. It is attached with Velcro.
2.	Remove the outer link top foam cover. It is attached with Velcro.
3.	Remove the outer link top sheet metal cover.
4.	Replace the two batteries.
5.	Replace the covers.

To replace the Encoder Battery in the 6-axis outer link, perform the procedure shown in [Table 2-5](#):

Table 2-5: Replacing the Encoder Battery in the Six-Axis Outer Link

Step	Action
1.	Remove the outer link foam cover from the side of the of the outer link with the cable grommet. It is attached with Velcro.

Step	Action
2.	Replace the two batteries.
3.	Replace the cover.

If the “Encoder Battery Down” error is generated, the robot must be re-calibrated after this procedure. See [Calibrating the Robot: Setting the Encoder Zero Positions](#). Otherwise it is not necessary to re-calibrate the robot.

Calibrating the Robot: Setting the Encoder Zero Positions

Cal_PP is a service program that must be run to set the zero positions of the absolute encoders on each motor. The zero positions must be re-established if any of the motors are replaced, their cables disconnected for a long duration, or the encoder backup battery has been disconnected. Cal_PP is supplied on the flash drive of the robot and is available in the Support area of the Brooks website. To run Cal_PP, the controller must be configured to run GPL programs and Cal_PP must be loaded into the controller’s memory (See ["Appendix D: Preventative Maintenance" on page 1](#)).

Tools Required

- Calibration Kit with M6 X 40 mm dowel
- (2) M5 X 45 mm Socket Head Cap Screws
- (2) M5 jam nuts

To define the zero positions of the PFDD robot axes using Cal_PP, perform the procedure in [Table 2-6](#):

Table 2-6: Defining Axes Zero Positions

Step	Action
1.	Enable power to the robot’s controller, but do not turn on power to the motors. (This procedure should be executed with motor power off. The robot does not move.)

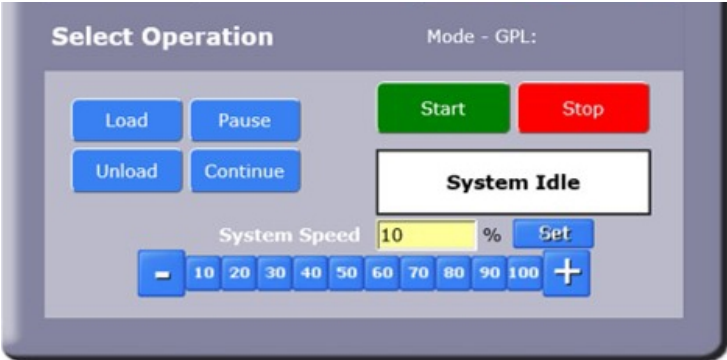
Step	Action
2.	<p>The CALPP program is typically installed at the factory and should be loaded into flash memory. Using the web-based Operator Control Panel, click UnLoad to unload any currently loaded programs. This ensures that no GPL project is currently selected for execution.</p> 
3.	Click Load . This displays a list of projects that are in the flash disk and available for execution.
4.	In the window, click CALPP_RevXX .
5.	When ready to execute the project, click Start .
6.	If CALPP is not loaded in the robot, first Load Cal_PP into the controller's memory from a PC, using the web Operator Control Panel, as described in the <i>Software Reference</i> section.
7.	Manually move the robot into the configuration shown below.
8.	Ensure Z-axis is resting on the lower hard stop by releasing the Z axis brake by pushing on the brake release button under the inner link while supporting the robot arm with your hand, and lowering the robot arm gently until it rests on the lower hard stop.
9.	Install an M6 X 40mm Calibration Pin in the base platter.
10.	Rotate J3 counter-clockwise when viewed looking down until its hard stop.
11.	Start CAL_PP_XX .
12.	For the PFDD4, rotate J4 counter-clockwise when viewed looking down until its hard stop.

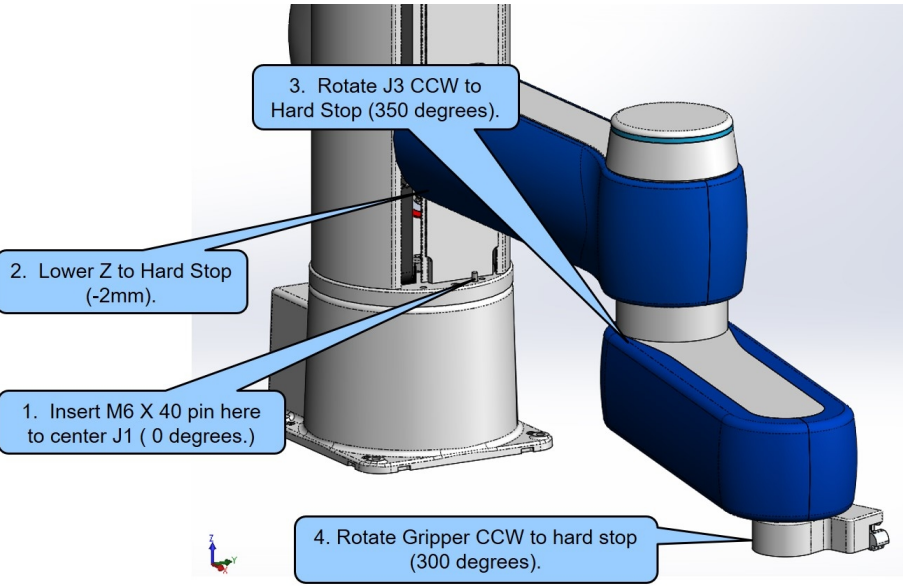
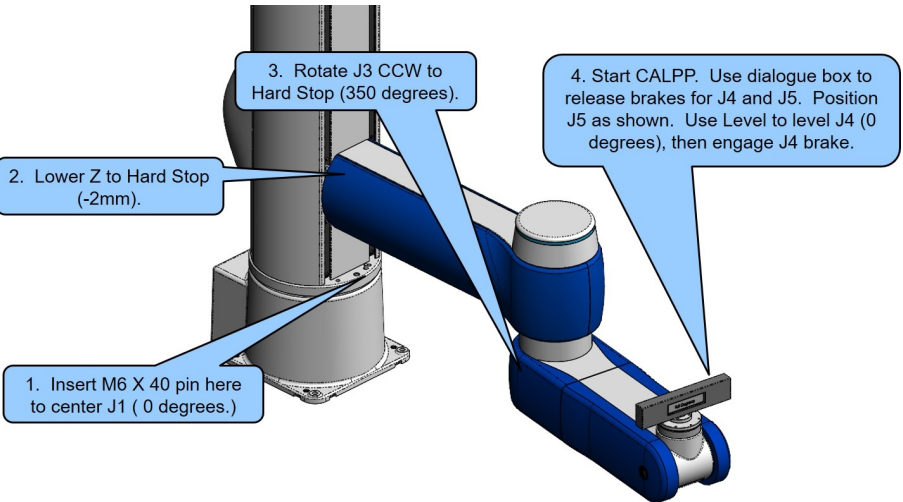
Step	Action
<p>13.</p>	<p>For the PFDD6, position the robot as follows.</p>  <p>1. Insert M6 X 40 pin here to center J1 (0 degrees.)</p> <p>2. Lower Z to Hard Stop (-2mm).</p> <p>3. Rotate J3 CCW to Hard Stop (350 degrees).</p> <p>4. Rotate Gripper CCW to hard stop (300 degrees).</p> <p>CALPP Position PFDD4</p>
<p>14.</p>	 <p>1. Insert M6 X 40 pin here to center J1 (0 degrees.)</p> <p>2. Lower Z to Hard Stop (-2mm).</p> <p>3. Rotate J3 CCW to Hard Stop (350 degrees).</p> <p>4. Start CALPP. Use dialogue box to release brakes for J4 and J5. Position J5 as shown. Use Level to level J4 (0 degrees), then engage J4 brake.</p> <p>CALPP Position PFDD6 Step One</p>

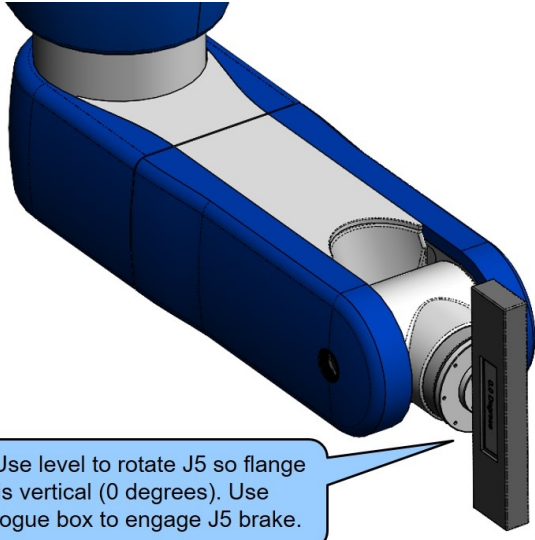
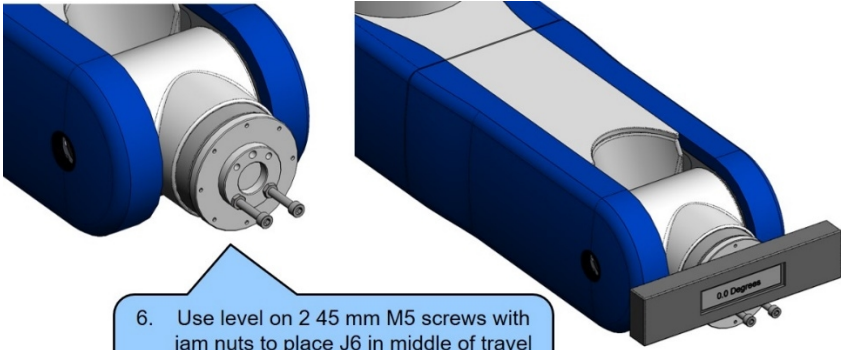
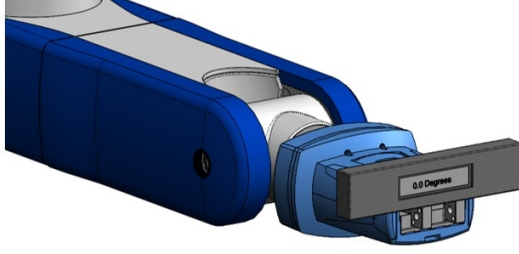
Step	Action
15.	 <p>5. Use level to rotate J5 so flange is vertical (0 degrees). Use dialogue box to engage J5 brake.</p> <p>CALPP Position PFDD6 Step Two</p>
16.	 <p>6. Use level on 2 45 mm M5 screws with jam nuts to place J6 in middle of travel (0 degrees), with M5 dowel hole as shown. Then execute CALPP.</p> <p>CALPP Position PFDD6 Step Three</p>
17.	 <p>When grippers are attached to robot, steps 4, 5, and 6 can be performed using surfaces on the gripper. Then execute CALPP.</p> <p>CALPP Position PFDD6 With Gripper</p>

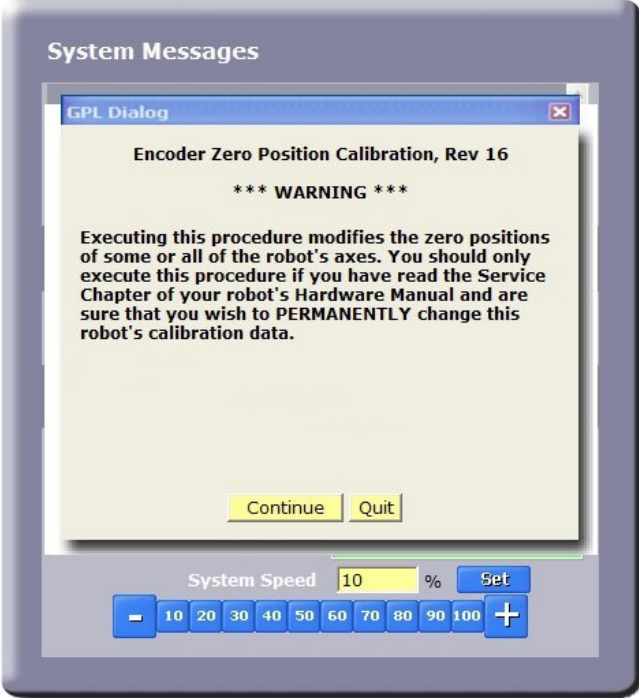
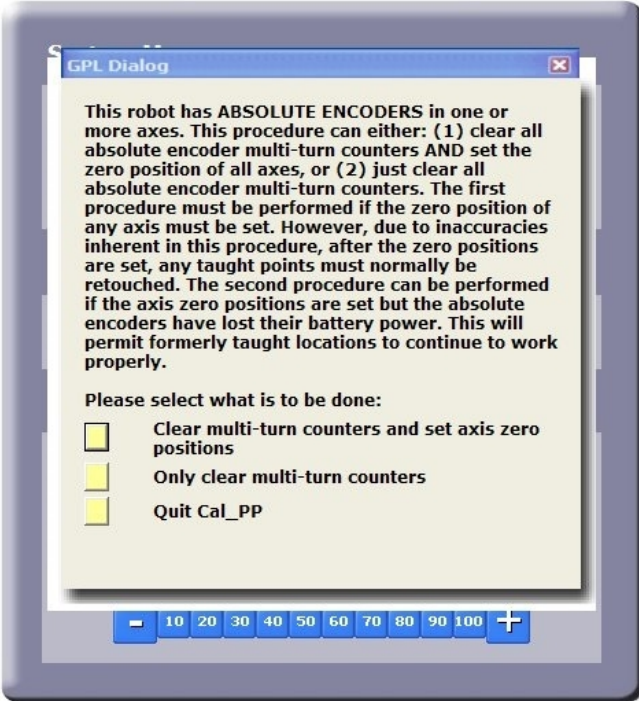
Step	Action
<p>18.</p>	<p>With the CALPP application loaded, click Start. An application should start and prompt the user to confirm the correct robot position for calibration.</p> 
<p>19.</p>	

Step	Action
20.	<p>A dialogue box will display that allows the J4 and J5 brake to be released for PFDD6 to allow it to be positioned correctly for CALPP.</p> <p>After the robot is correctly positioned, execute CALPP. The CALPP application takes about one minute to run.</p>
21.	<p>After calibration is complete, use the brake release button and move the Z-axis a few millimeters away from the hard stop. Failing to do this will produce an error as the robot is outside of the soft stop limits.</p>
22.	<p>Ensure that the pin is removed from the base rotation plate.</p>
23.	<p>Enable power and home the robot. Calibration does not take effect until the robot is homed.</p>

Replacing Belts and Motors



The timing belts and harmonic drives may need service after 20,000 hours, depending on the payload and duty cycle. The motors are designed to last the life of the robot. It is not expected that they will need to be replaced in the field. In most cases, if a belt or a motor needs to be replaced, the robot should be returned to the factory. While there are procedures in this manual for replacing belts and motors, only experienced service technicians should attempt these procedures.

General Belt Tensioning

The PFDD robots have been designed to make belt tensioning very simple. See ["Appendix D: Preventative Maintenance" on page 1](#) for belt tension specifications.

Tensioning or Replacing the J2 (Z Column) Belts

Tensioning the 1st Stage Belt

 DANGER Electrical Shock	
<p>Before tensioning the timing belts or replacing any motors, the AC power should be disconnected. Removing the rear cover allows access to the AC power terminals.</p>	



Tools Required

- Gates Sonic Belt Tension Meter, Model 508 C
- 2.0 mm hex driver or hex L wrench
- 4.0 mm hex ball end driver

Table 2-7: Adjusting Belt Tension

Step	Action
1.	Turn off robot power and remove the AC power cord.
2.	Remove the curved rear cover of the robot.
3.	Loosen the (4) M5 locking screws on the J1 Motor Mount Bracket to allow the Mount Bracket to slide up and down.
4.	Measure the tension with the belt tension meter as described in "Appendix E: Belt Tensions, Gates Tension Meter" on page 1.
5.	Adjust the M5 tension screw.
6.	After adjusting the tension screw, tighten the M5 locking screws to lock the assembly in place. Replace the rear cover.

Tensioning the 2nd Stage Belt

 DANGER Electrical Shock	
<p>Before tensioning the timing belts or replacing any motors, the AC power should be disconnected. Removing the rear cover allows access to the AC power terminals.</p>	



Tools Required

- Gates Sonic Belt Tension Meter, Model 508C
- 2.0 mm hex driver or hex L wrench
- 3.0 mm hex driver
- 4.0 mm ball end hex

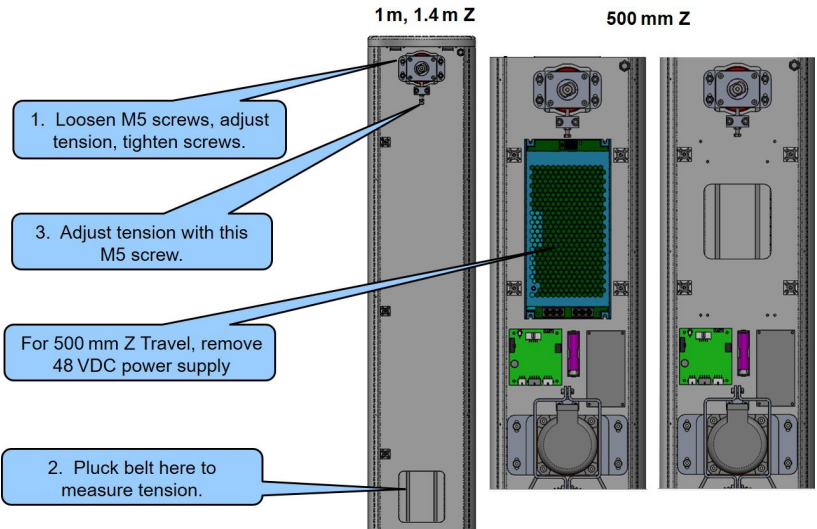
Table 2-8: Tensioning the 2nd Stage J1 Belt

Step	Action
1.	Turn off the robot power and remove the AC power cord.
2.	Remove the curved rear cover of from the Z column.
3.	<p>Loosen the (4) M5 locking screws on the Z idler block.</p>  <p>The diagram illustrates the Z column assembly for three different travel distances: 1m, 1.4m Z; 500 mm Z. It shows the idler block at the top and the belt attachment point at the bottom. Callouts provide specific instructions for each configuration.</p>
4.	<p>For the 1.42 m and 1.0 m Z travel robots, the tension screw and belt tension access hole can be accessed at this point. For the 500 mm Z travel robot it is necessary to remove the 48VDC power supply in order to access the belt tension access hole and the tension screw. As an alternative, the top cover and front cover may be removed to access the stage 2 timing belt from the front of the robot. This is the easier method if tape seals are not installed.</p>
5.	<p>Adjust the second stage Z belt tension per "Appendix E: Belt Tensions, Gates Tension Meter" on page 1, tighten clamping screws, and replace parts. It may be helpful to move the carriage upwards on the taller robots so that the distance from the top idler pulley to belt attachment on the Z carriage is 500 mm, in order to get a higher frequency on the belt, which can be easier to measure with the tension meter. Use the 500 mm span in this case.</p>

Replacing the Z column Stage One Timing Belt

 DANGER Electrical Shock	
Before replacing the power supplies, the AC power should be removed.	

Tools Required

- 2.0 mm hex driver
- 4.0 mm ball end hex driver
- 2.5 mm hex driver or hex L wrench

Spare Parts Required

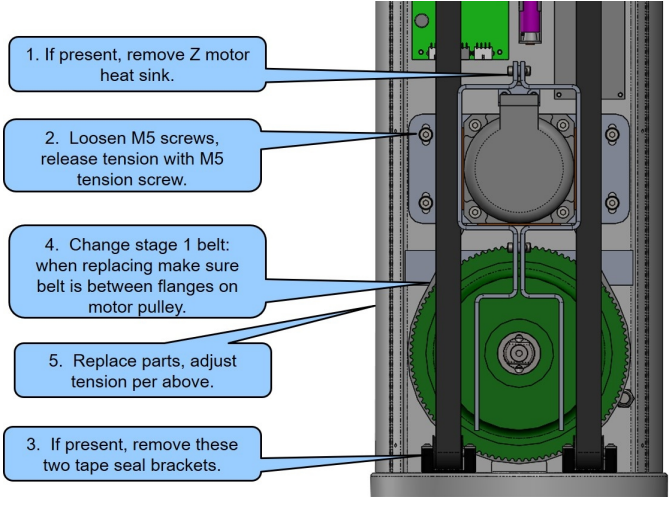

- J2 Stage One Belt, PN PFD0-MC-X0006.

Table 2-9: Replacing the Z Column Stage One Timing Belt

Step	Action
1.	Turn off the robot power and remove the AC power cord.
2.	Remove the curved rear cover from the Z column.
3.	Remove the Z motor heat sink if it is installed.  <ul style="list-style-type: none"> 1. If present, remove Z motor heat sink. 2. Loosen M5 screws, release tension with M5 tension screw. 4. Change stage 1 belt: when replacing make sure belt is between flanges on motor pulley. 5. Replace parts, adjust tension per above. 3. If present, remove these two tape seal brackets.
4.	Loosen the M5 Z motor bracket clamping screws and release the tension on belt with the M5 tension screw.

Step	Action
5.	If present, remove the tape seal brackets. It may be necessary to release the tension on the tape seals first. In this case, slide the top plate laterally after removing screws from the top plate and front cover to release the tension on the tape seals and allow the front cover to be removed. It is not necessary to remove the tape seal tension brackets from the top of the Z carriage.
6.	Replace the Z stage one belt. When hooking the belt around the Z motor pulley, make sure that the belt is inside the flanges on the Z motor pulley.
7.	Adjust the belt tension per above, and replace the parts.
8.	Recalibrate the robot.

Replacing the Z Column Stage Two Timing Belt

 DANGER Electrical Shock	
<p>Before replacing the power supplies, the AC power should be removed.</p>	

Tools Required

- 2.0 mm hex driver
- 3.0 mm hex L wrench
- 3.0 mm hex driver
- 4.0 mm ball end hex driver

Spare Parts Required

- J2 Stage One Belt, PN PFD0-MC-X0006 (500 mm, 1000 mm, 1420 mm stroke)

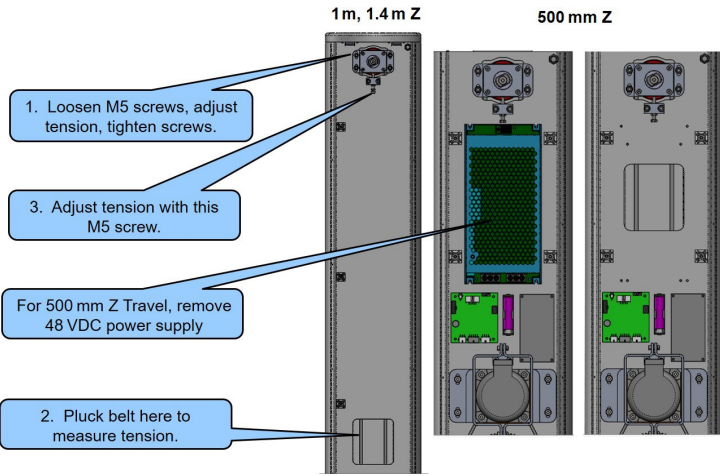

Table 2-10: Replacing the Z Column Stage Two Timing Belt

Step	Action
1.	Move the Z carriage to 640 mm height for the 1000 mm and 1420 mm Z travel robots, or 380 mm height for the 500 mm Z travel robot.
2.	Turn off the robot power and remove the AC power cord.

Step	Action
3.	<p>Remove the curved rear cover from the Z column.</p>  <p>1. Loosen M5 screws, adjust tension, tighten screws.</p> <p>3. Adjust tension with this M5 screw.</p> <p>For 500 mm Z Travel, remove 48 VDC power supply</p> <p>2. Pluck belt here to measure tension.</p>
4.	<p>Remove the top plate and front Z cover. If tape seals are present, slide the top plate laterally after removing screws from the top plate and front cover to release the tension on the tape seals and allow the front cover to be removed. It is not necessary to remove the tape seal tension brackets from the top of the Z carriage.</p>
5.	<p>Support the Z carriage and links with a stick, boxes, or other means to prevent it from dropping when the belt clamp is removed.</p>
6.	<p>For the 500 mm Z travel robot, remove the 48VDC power supply.</p>
7.	<p>Remove the Z belt clamp which should be accessible through the access cutout in the Z extrusion, change the Z belt, and replace the clamp.</p>
8.	<p>Tension the Z belt per above.</p>
9.	<p>Replace the parts.</p>
10.	<p>Recalibrate the robot.</p>

Tensioning or Replacing the Belts in the PFDD4

Tensioning the Belts in the PFDD4 Outer Link

 <b style="font-size: 1.2em;">DANGER Electrical Shock	
<p>Before tensioning the timing belts, the AC power should be disconnected. Removing the front cover allows access to the AC power terminals.</p>	

Tools Required

- Gates Sonic Belt Tension Meter, Model 508C
- 3.0 mm hex driver or hex L wrench
- 2.5 mm hex driver or hex L wrench
- 2.0 mm hex ball driver or hex L wrench

Table 2-11: Re-Tensioning the J4 Stage 1 Timing Belt

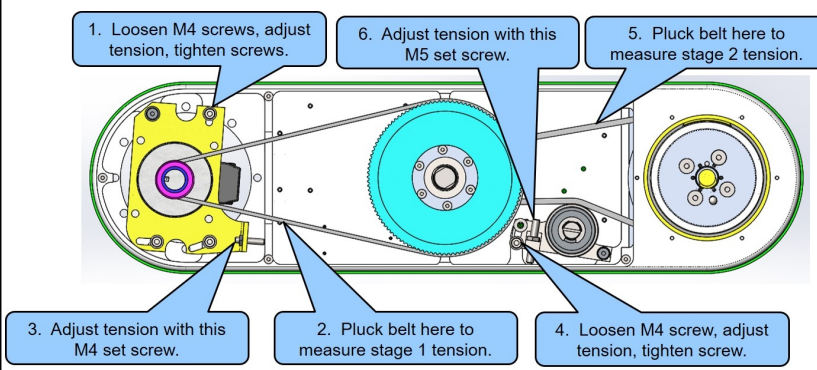
Step	Action
1.	Move the robot arm to a convenient height to allow access to the outer link of the robot.
2.	Turn off the robot power and remove the AC power cord.
3.	Remove the foam side cover on the outer link and the foam bottom cover. These are attached with Velcro.
4.	<p>Remove the sheet metal bottom cover.</p> 
5.	For stage 1, loosen the (3) M4 clamping screws, and the locknut on the tension set screw, adjust tension per Appendix E: Belt Tensions, Gates Tension Meter , and tighten the screws.

Step	Action
6.	For stage 2, loosen the M4 clamping screw and locknut on the tension screw, adjust tension per Appendix E: Belt Tensions, Gates Tension Meter , and tighten the screws.
7.	Replace the covers.

Replacing the Belts in the PFDD4 Outer Link

DANGER

<p>Before replacing the timing belts, the AC power should be disconnected. Removing the cover allows access to the AC power terminals.</p>	
--	---

Spare Parts Required



- J4 Stage One Belt, PN Gates GT3 Belt 3 mm pitch, 564-3M, 15 mm wide (PFD0-MC-X0050)
- J4 Stage Two Belt, PN Gates GT3 Belt 5 mm pitch, 3MR-564, 25 mm wide (PFD0-MC-X0051)

Table 2-12: Replacing the Belts in the PFDD4 Outer Link

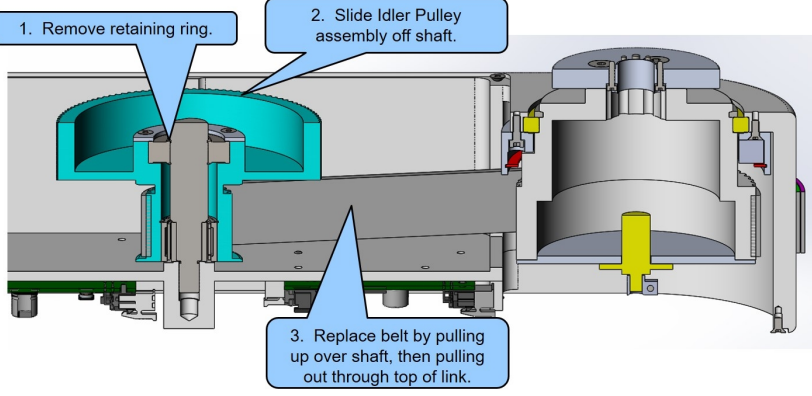
Step	Action
1.	Remove the top and bottom covers per above to access the belts.
2.	For the Stage One Belt, loosen the M4 clamping screws, release the belt tension with the tension set screw, and replace the belt.
3.	For the Stage Two Belt, remove the Stage One Belt per above, and then release the belt tension.
4.	Remove the retaining ring that retains the large idler pulley, and remove the idler pulley.
5.	Pulley the Stage Two Belt up over the idler pulley shaft, and then remove by pulling out through the top of the outer link over the output pulley.
6.	Replace the parts, re-tension the belts, and replace the covers.

Step	Action
7.	<p>Recalibrate the robot.</p>  <p>1. Remove retaining ring.</p> <p>2. Slide Idler Pulley assembly off shaft.</p> <p>3. Replace belt by pulling up over shaft, then pulling out through top of link.</p>

Replacing the Robot Main Controller

 DANGER Electrical Shock	
Before replacing the Robot Controller, the AC power should be removed.	

Tools Required:

- 2.5 mm hex driver or hex L wrench
- 2.0 mm hex driver or hex L wrench
- 5.0 mm socket driver

Spare Parts Required for main robot controller

- PreciseFlex PFD0 Controller PN PFD0-EA-00001-3

Prior to replacing the controller, if the controller will boot up, the user may wish to make copies of both the robot PAC files (config directory), any project files (projects directory), and the “Sys” files (sys directory), to a PC. These files can be copied using <ftp://192.168.0.1/flash> or the IP address of the controller.

Table 2-13: Replacing the Robot Controller

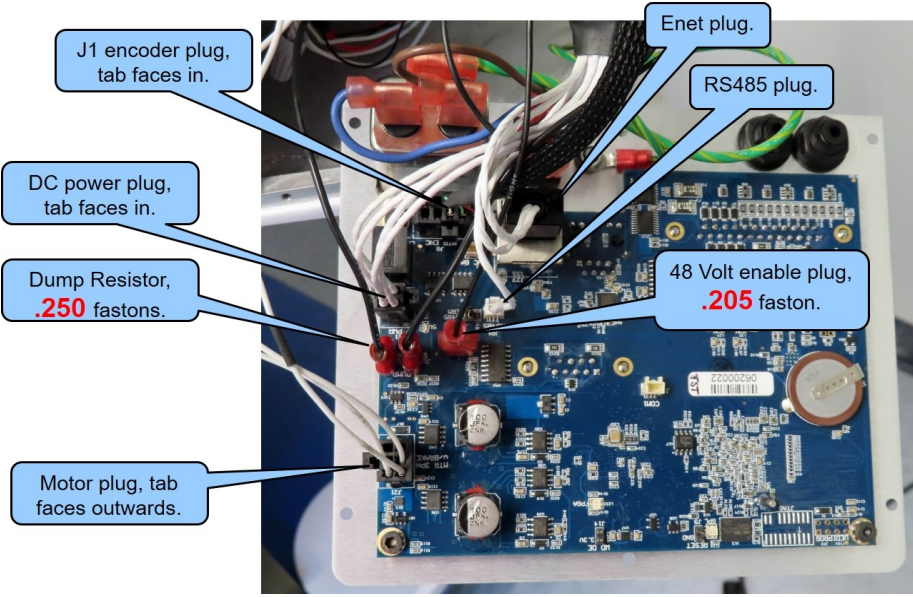
Step	Action
1.	<p>Turn off the robot power and remove the AC power cord.</p>  <p>The image shows the rear panel of the robot controller. It features a power switch labeled '100-240 VAC 50-60 Hz 0.99W' with a green indicator light. To the right, there are several ports: a 'Pendant' port, an 'Accessory' port, a 'Digital I/O 12 PSI Max' port, and two 'A1' ports. The panel is secured with screws around the perimeter.</p>
2.	<p>Remove the connector panel from the base of the robot by removing M3 X 6 mm flat head screws.</p>  <p>The image shows a close-up of the robot controller board with several connectors labeled with callouts:</p> <ul style="list-style-type: none"> J1 encoder plug, tab faces in. DC power plug, tab faces in. Dump Resistor, .250 fastons. Motor plug, tab faces outwards. Enet plug. RS485 plug. 48 Volt enable plug, .205 faston.
3.	<p>Remove main robot controller, PFD0-EA-00001 by removing the (3) M3 X 8 mm SHCS and the D-Sub standoffs from the connector side of the panel.</p>
4.	<p>Replace the controller and connect the wires as shown above.</p>
5.	<p>Replace the connector panel.</p>

Step	Action
6.	Reload the robot PAC files (config directory), any project files (projects directory), and the "Sys" files (sys directory), from a PC. These files can be copied using ftp://192.168.0.1/flash or the IP address of the controller.
7.	<p>Recalibrate the robot.</p> <div style="border: 1px solid black; padding: 5px;"> <p>FTP directory /flash/ at 192.168.0.1</p> <p>To view this FTP site in File Explorer: press Alt, click View, and then click Open FTP Site in File Explorer.</p> <p><u>Up to higher level directory</u></p> <pre> 01/01/1970 12:00AM Directory . 04/13/2020 02:41PM Directory .. 01/27/2020 05:19PM Directory config 04/03/2020 03:35PM Directory projects 04/03/2020 03:34PM Directory sys </pre> </div>

Replacing the Z-axis Slave Controller

DANGER

Electrical Shock

Before replacing any Controller, the AC power should be removed.

Tools Required

- 2.0 mm hex driver
- 2.5 mm hex driver

Spare Part Required:



- G6X0-EA-00202 with thermal pad

Table 2-14: Replacing the Z Axis Slave Controller

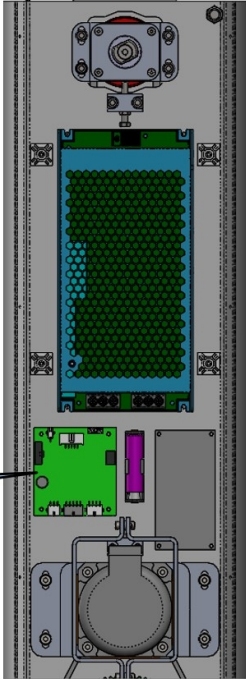
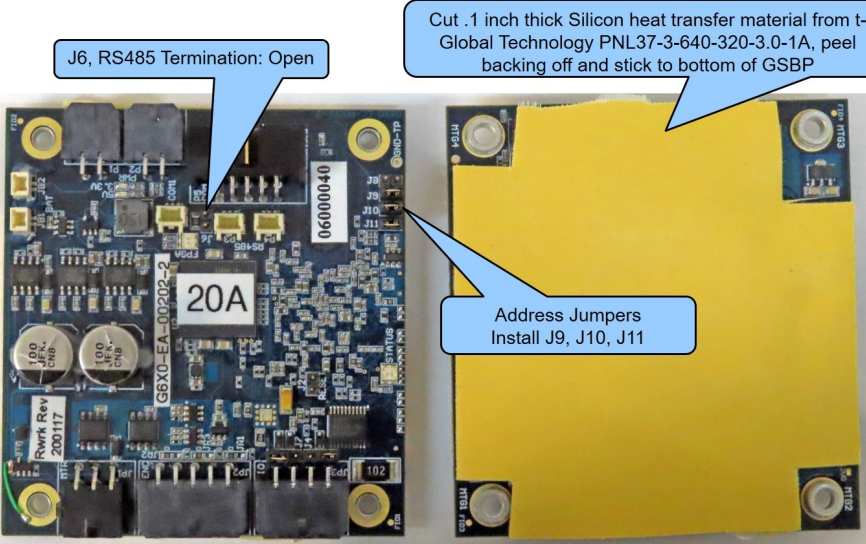
Step	Action
1.	Turn off the robot power and remove the AC power cord.
2.	Remove the curved read cover from the Z column.
3.	Remove the gripper controller by removing the (4) M3 X 10 mm SHCS and unplugging the cables.

Step	Action
4.	Replace the slave controller and re-attach the harness.
5.	Set the jumpers correctly for the address and termination.
6.	Replace the curved rear cover.
7.	<p>Recalibrate the robot.</p> 
8.	

Replacing the J3 Axis Slave Controller

 DANGER Electrical Shock	
Before replacing any Controller, the AC power should be removed.	

Tools Required

- 2.5 mm hex driver

Spare Part Required



- G6X0-EA-00202

Table 2-15: Replacing the J3 Axis Slave Controller

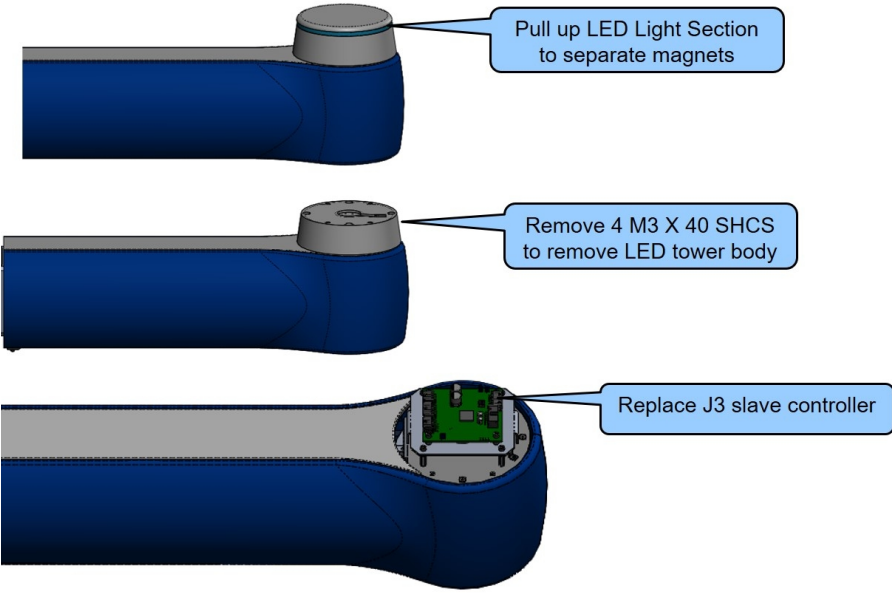
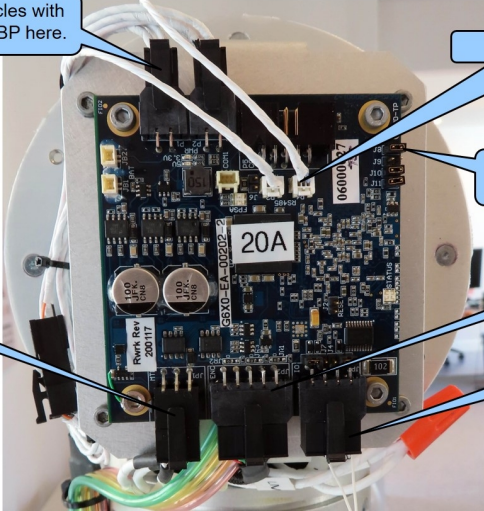
Step	Action
1.	Turn off the robot power and remove the AC power cord.
2.	Remove the LED light tower cover by pulling up on the light section to release magnets.
3.	Remove the LED light tower body by removing the (4) M3 X 40 mm SHCS. Unplug LED pigtail.
4.	Replace the slave controller and re-attach the harness.
5.	Set the jumpers correctly for the address and termination.
6.	Replace the LED light tower parts.

Step	Action
7.	<p>It is not necessary to recalibrate the robot if only this controller is replaced.</p>  <p>Pull up LED Light Section to separate magnets</p> <p>Remove 4 M3 X 40 SHCS to remove LED tower body</p> <p>Replace J3 slave controller</p>
8.	 <p>Plug both 4 pin receptacles with socket contacts into GSBP here.</p> <p>RS485 daisy chain</p> <p>Address Jumpers Install J8, J10, J11</p> <p>J3 encoder.</p> <p>J3 LED light tower.</p> <p>J3 motor.</p>

Replacing the J4 or Gripper Slave Controller in PFDD4

 DANGER Electrical Shock	
Before replacing any Controller, the AC power should be removed.	

Tools Required

- 2.5 mm hex driver

Spare Part Required:

- G6X0-EA-00202 for J4 axis (20A, differential encoder)
- G6X0-EA-00101 for Gripper (10A, single ended encoder)

Table 2-16: Replacing the J4 Axis Slave Controller

Step	Action
1.	Turn off the robot power and remove the AC power cord.
2.	Remove the foam side cover from the outer link. It is attached with Velcro.
3.	Remove the foam top cover from the outer link. It is attached with Velcro.
4.	Remove the sheet metal cover from the outer link.
5.	Replace the slave controller (GSBP).
6.	Set the jumpers correctly for the address and termination.
7.	Recalibrate the robot.

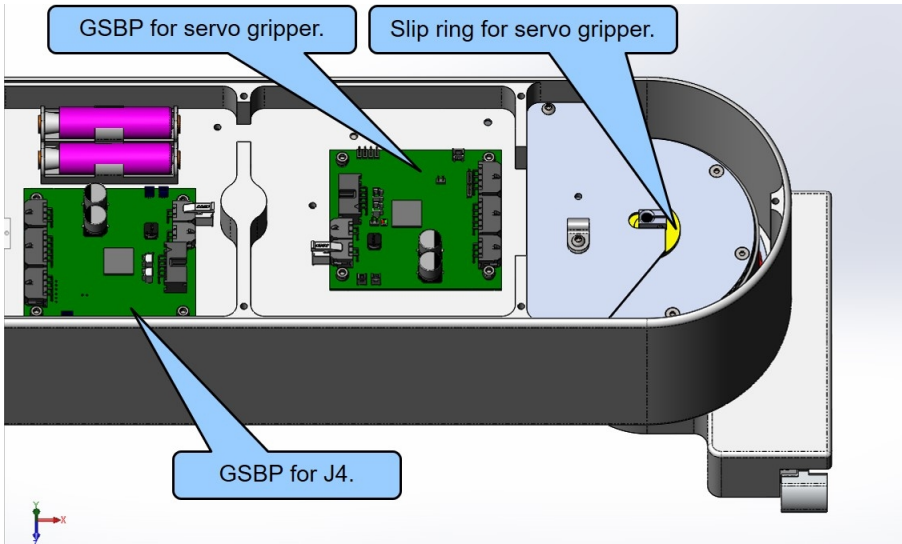
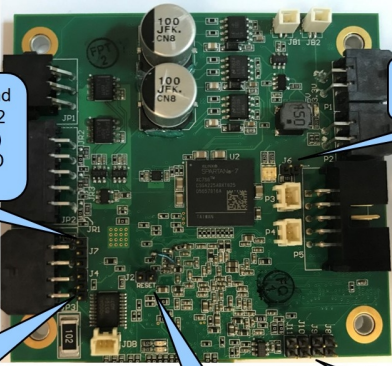
Step	Action
8.	<p>Replace the covers.</p>  <p>GSBP for servo gripper.</p> <p>Slip ring for servo gripper.</p> <p>GSBP for J4.</p>
9.	 <p>Jumper J7: connect pins 1 and 2 for TX input, connect pins 2 and 3 (towards top of board) to connect DOUT3, with LED drive resistor.</p> <p>RS485 Jumper: J6 open if servo gripper, closed if not.</p> <p>Jumper J4: connect pins 1 and 2 for RX input, connect pins 2 and 3 (towards middle of board) to connect DIN1.</p> <p>Reset, leave open.</p> <p>Address Jumpers: J10 installed, J8, J9, J11 open.</p> <p>GSBP for J4 Axis, PFDD4</p>

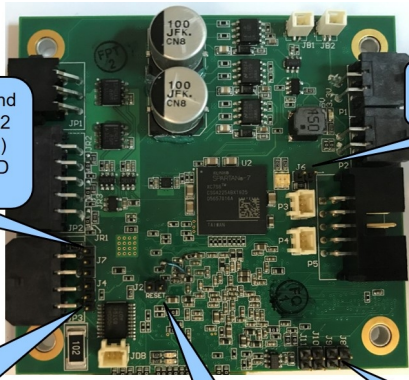
Step	Action
10.	 <p>Jumper J7: connect pins 1 and 2 for TX input, connect pins 2 and 3 (towards top of board) to connect DOUT3, with LED drive resistor.</p> <p>Jumper J4: connect pins 1 and 2 for RX input, connect pins 2 and 3 (towards middle of board) to connect DIN1.</p> <p>RS485 Jumper: J6 closed for servo gripper on 4 axis.</p> <p>Reset, leave open.</p> <p>Address Jumpers: J8, J9 installed, J10, J11 open.</p> <p>GSBP for 23N Servo Gripper, PFDD4</p>

Replacing the Gripper and Slip Ring in PFDD4

DANGER
Electrical Shock

Before replacing any Controller, the AC power should be removed.

Tools Required

- 1.5 mm hex driver
- 2.0 mm hex driver
- 2.5 mm hex driver

Spare Parts Required:

- 23N Servo Gripper with Spring Return PF0S-MA-00001
- Slip Ring for 23N Servo Gripper with Spring Return PF04-MA.00010

Table 2-17: Replacing the 23N Servo Gripper or Slip Ring

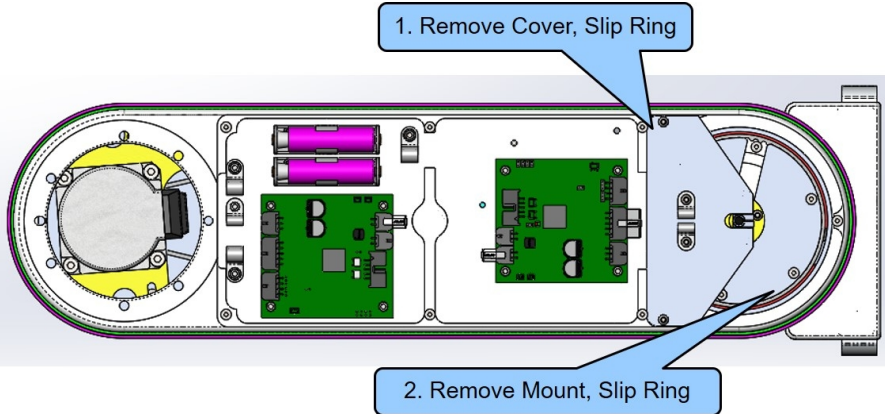
Step	Action
1.	Turn off the robot power and remove the AC power cord.
2.	Remove the foam side cover from the outer link. It is attached with Velcro.
3.	Remove the foam top cover from the outer link. It is attached with Velcro.
4.	Remove the sheet metal cover from the outer link.
5.	Remove cover, slip ring and mount, and slip ring.
6.	Remove the (6) M2 X 10 mm SHCS to release gripper, then unplug slip ring connectors in gripper.
7.	At this point, the gripper or the slip ring can be replaced.
8.	Reassemble the parts. Be careful not to pinch the slip ring cable, it fits in the notch in the flange.
9.	<p>The robot does not need to be re-calibrated after changing the slip ring or gripper.</p>  <p>The diagram shows a top-down view of the robot's chassis. Two callout boxes with blue backgrounds and white text point to specific areas: '1. Remove Cover, Slip Ring' points to the top-right flange area, and '2. Remove Mount, Slip Ring' points to the bottom-right flange area. The internal components, including a green PCB, two purple batteries, and a servo motor, are visible.</p>

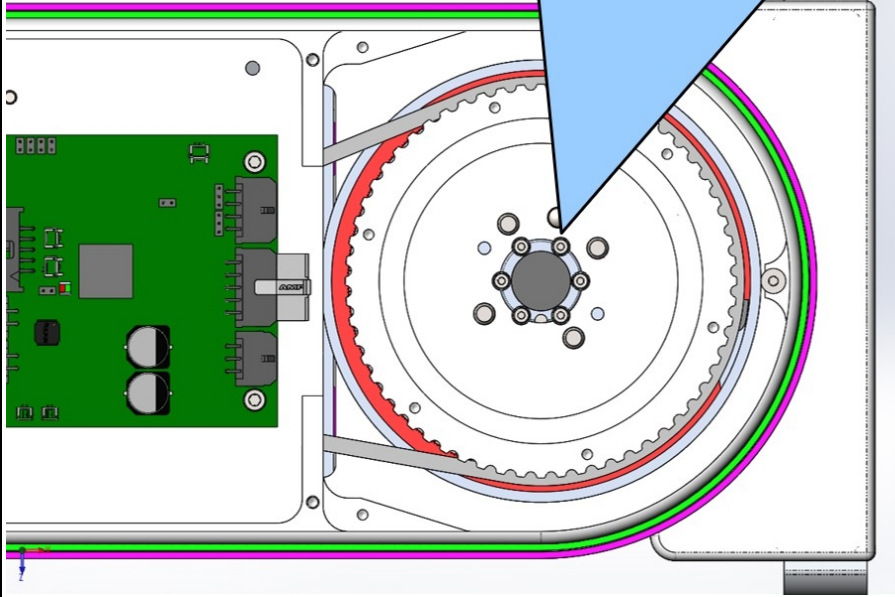
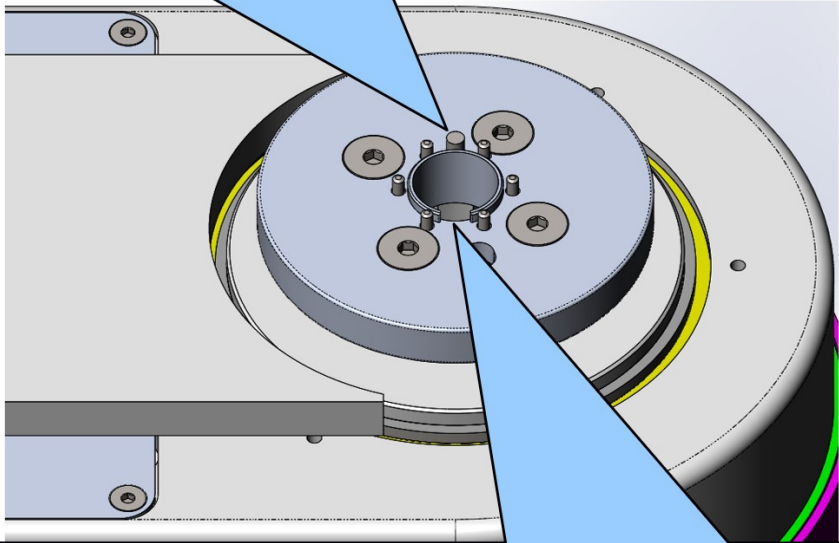
Step	Action
10.	<p data-bbox="300 268 1203 359">Remove 6 M2 X 10 SHCS to remove gripper, then unplug slip ring connectors in gripper to free gripper.</p> 
11.	<p data-bbox="321 993 1211 1041">When replacing gripper, note this dowel fits in notch in gripper housing.</p>  <p data-bbox="300 1612 1187 1661">When replacing gripper, note slip ring harness fits in notch in flange.</p>

Replacing the Main Harness

Replacement of the Main Robot Harness is typically only performed at the factory. The Main Robot Harness is intended to last for the life of the robot.

Replacing the J3 Clock Spring Harness to the J4 Motor

Tools Required

- 2.0 mm hex driver
- 2.5 mm hex driver

Spare Parts Required

- J3 Clock Spring Harness PN PFD0H-MA-00021-X2

Table 2-18: Replacing the Harness

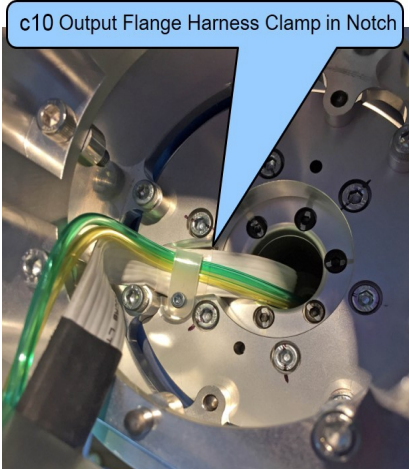
Step	Action
1.	Remove the LED light tower and J3 Slave Controller per instructions for these assemblies.
2.	For the PFDD4, remove the foam side covers, the foam bottom cover, the sheet metal bottom cover, the foam top cover, and the sheet metal top cover to expose the harness.
3.	For the PFDD4, unplug the end of the clockspring harness from the J4 slave controller in the outer link, then remove the outer link from the J3 spacer by removing the (6) M5 X 12 mm SHCS.
4.	For the PFDD4 remove the harness clamp from the J3 output flange to release the outer link end of the harness. 

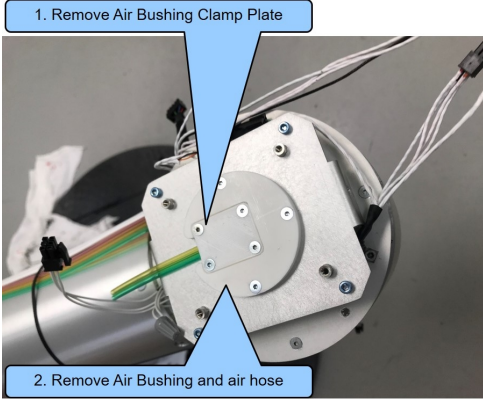
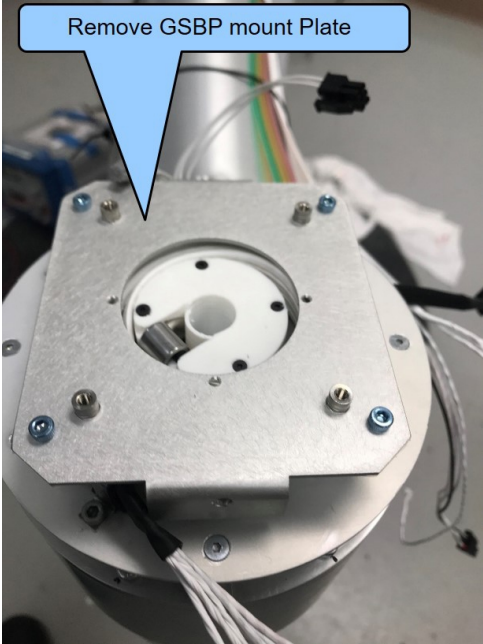
Step	Action
5.	For the PFDD6, simply remove the J4 foam end cover and unplug the J4 end of the clockspring harness from the J4 slave amp (GSBP).
6.	<p>Remove the air hose clamp plate and thru hole bushing and pull the air hose up through J3.</p>  <p>1. Remove Air Bushing Clamp Plate</p> <p>2. Remove Air Bushing and air hose</p>
7.	 <p>Remove GSBP mount Plate</p>

Step	Action
8.	 <ol style="list-style-type: none"> 1. To remove harness, do these operations in reverse. Make sure you are completely clockwise against the hard stop looking from the top. Route so there is a total of four wraps 2. Clamp with Cable Clamp, Clip, J3 (PFD0-MC-M0132), neoprene strip, M3-10 FHCS and Loctite 222. 3. Install Lid, Bushing, J3 so it constrains the harness folded over going down elbow. Fasten with M2-6 FHCS Alloy and Loctite 222.
9.	Remove the clockspring harness as shown in Step 8 , and then install the new harness. <i>For the PFDD4 it is important to ensure that the harness is clamped in the notch in the J3 output flange as shown, or the J4 motor will interfere with the harness.</i>
10.	Replace the parts.
11.	For the PFDD4, it will be necessary to recalibrate the robot, as the J4 encoder was disconnected from the battery backup when the outer link was removed.
12.	For the PFDD6, it is not necessary to recalibrate the robot as the J3 encoder is a single turn absolute encoder and the J3 slave amp does not require an external battery.

Replacing the J4 to Gripper Controller Harness in the PFDD4

Tools Required

- 2.0mm hex driver
- 2.5mm hex driver

Spare Parts Required:

- Harness PN PFD0H-MA-00017

Table 2-19: Replacing the Harness

Step	Action
1.	Remove the foam side covers, the foam top cover, and the sheet metal top cover from the outer link.
2.	Replace the harness between the J4 slave controller and the gripper controller.
3.	Replace the covers. It is not necessary to recalibrate the robot.

Replacing the J4 slave controller in the PFDD6

Tools Required

- 2.0 mm hex driver
- 2.5 mm hex driver
- 5.0 mm hex socket driver

Spare Parts Required:

- Slave controller PN G6X0-EA-00202-3A for J4 axis (20A, differential encoder)

Table 2-20: Replacing the J4 Slave Controller in the PFDD6

Step	Action
1.	Remove the foam end cover from J4 and the bottom cover from J4.
2.	Remove the J4 controller mount plate from the bottom of J4.
3.	Unplug the J3 to J4 harness and the J4 to J5 harness and the motor connectors.
4.	Replace the J4 slave controller (GSBP).
5.	Replace the parts.

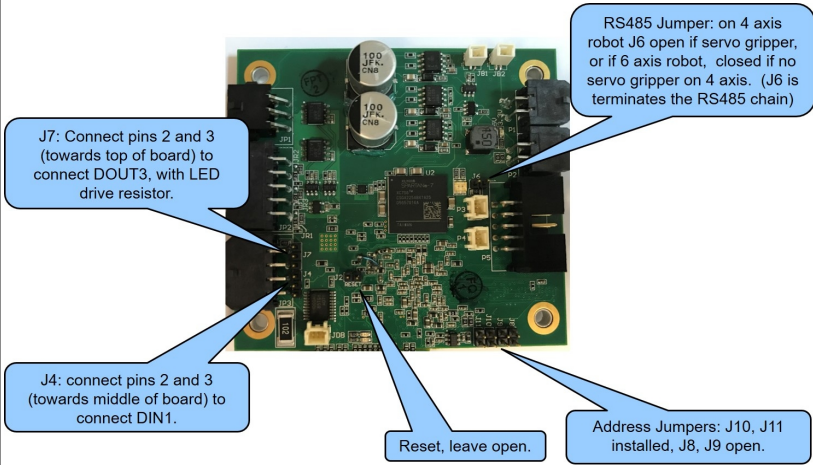
Step	Action
6.	<p>Recalibrate the robot.</p>  <p>The diagram shows a green PCB controller board with several callouts:</p> <ul style="list-style-type: none"> J7: Connect pins 2 and 3 (towards top of board) to connect DOUT3, with LED drive resistor. J4: connect pins 2 and 3 (towards middle of board) to connect DIN1. RS485 Jumper: on 4 axis robot J6 open if servo gripper, or if 6 axis robot, closed if no servo gripper on 4 axis. (J6 is terminates the RS485 chain) Reset: leave open. Address Jumpers: J10, J11 installed, J8, J9 open.

Replacing the J4 to J5 or J5 to J6 Controller Harness, J5 or J6 slave controller in the PFDD6

Tools Required

- 2.0 mm hex driver
- 2.5 mm ball end hex driver

Spare Parts Required

- Harness PN PFD0H-MA-00016
- Slave controller PN G6X0-EA-00202-3A for J4 axis (20A, differential encoder)

Table 2-21: Replacing the Controller Harness or Slave Controller

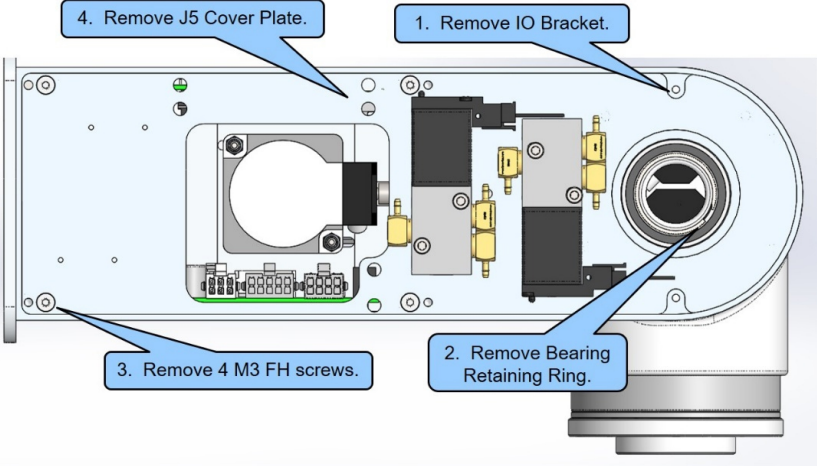
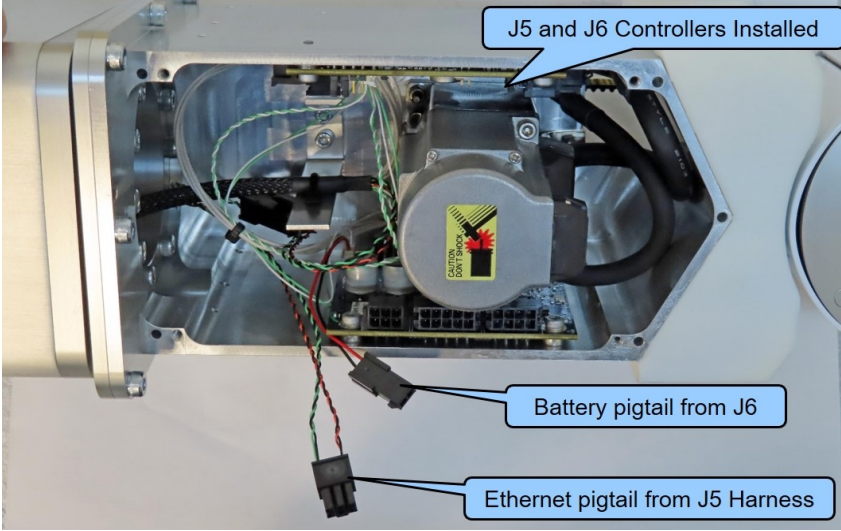
Step	Action
1.	<p>Remove the foam side cover from J5, the foam end cover from J4, and the J5 cover plate</p>  <p>4. Remove J5 Cover Plate.</p> <p>1. Remove IO Bracket.</p> <p>3. Remove 4 M3 FH screws.</p> <p>2. Remove Bearing Retaining Ring.</p>
2.	 <p>J5 and J6 Controllers Installed</p> <p>Battery pigtail from J6</p> <p>Ethernet pigtail from J5 Harness</p>

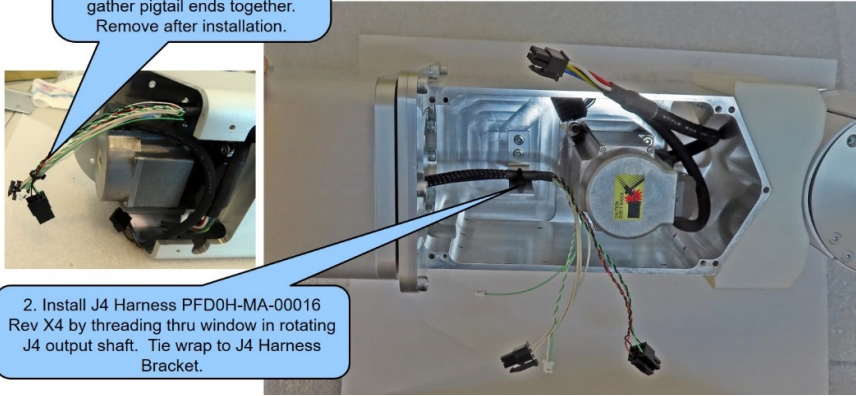
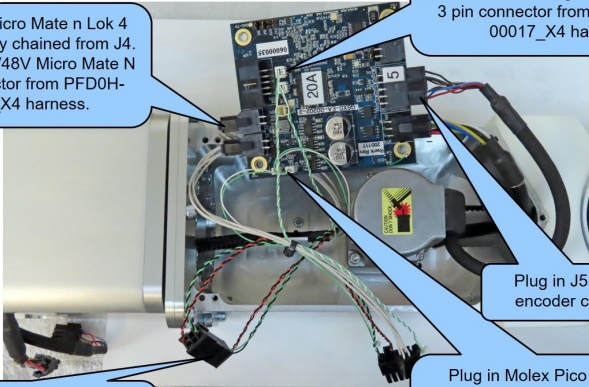
Step	Action
<p>3.</p>	 <p>6 conductor pin housing this end to extend Enet daisy chain. Easier to fish cable thru J4 housing if small zip tie used to gather pigtail ends together. Remove after installation.</p> <p>2. Install J4 Harness PFD0H-MA-00016 Rev X4 by threading thru window in rotating J4 output shaft. Tie wrap to J4 Harness Bracket.</p>
<p>4.</p>	 <p>Plug in 24/48V Micro Mate n Lok 4 pin connector daisy chained from J4. Plug in second 24/48V Micro Mate N Lok 4 pin connector from PFD0H-MA-00017_X4 harness.</p> <p>Plug in Molex Pico Clasp 3 pin connector daisy chained from J4 into RS485 socket. Plug in second Molex 3 pin connector from PFD0H-MA-00017_X4 harness.</p> <p>Plug in J5 motor and encoder connectors.</p> <p>Plug in Micro Mate n Lok 6 pin Ethernet from PFD0H-MA-00017_X4 harness into 6 pin connector daisy chained from J4.</p> <p>Plug in Molex Pico Clasp 2 pin connector daisy chained from J4 into battery socket. Plug in second Molex 2 pin connector from PFD0H-MA-00017_X4 harness.</p>

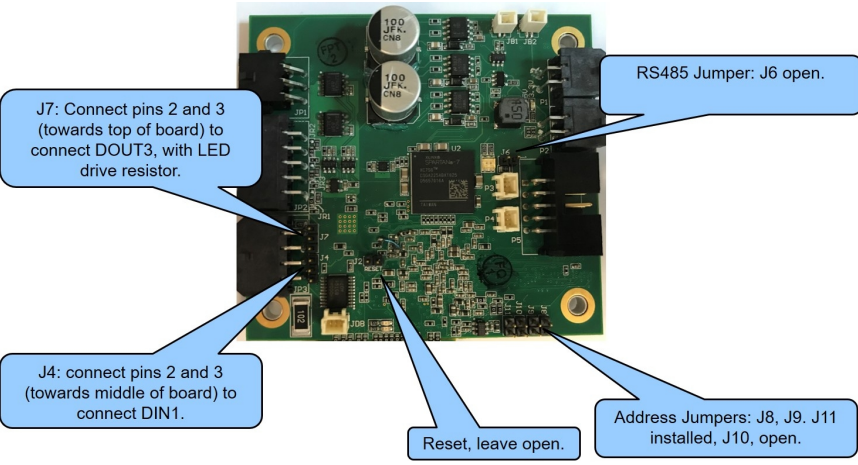
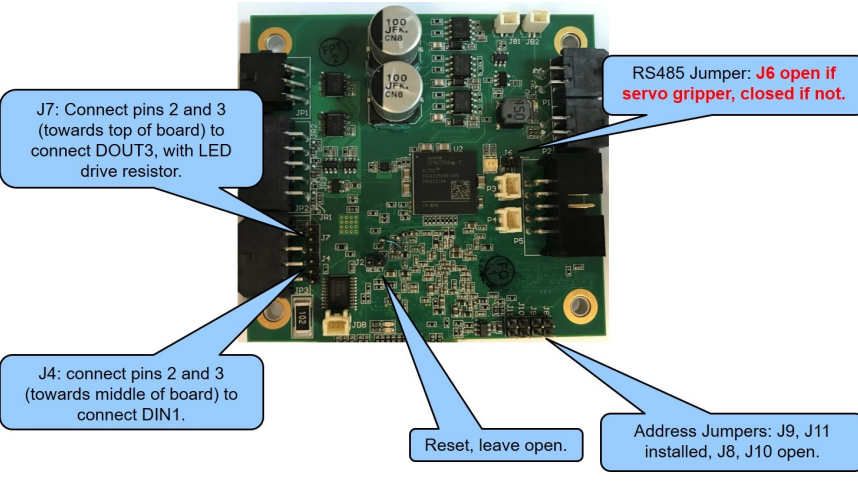
Step	Action
5.	 <p>Figure 2-4: J5 Slave Controller (GSBP) Jumpers</p>
6.	 <p>Figure 2-5: J6 Slave Controller (GSBP) Jumpers</p>
7.	Cut the tie wrap holding the J4 to J5 harness to the harness bracket in the J5 housing.
8.	Remove the J5 slave controller (GSBP) from the J5 side wall and unplug the J4 harness connectors.
9.	Unplug the harness from the J4 slave controller.
10.	Pull the J4 to J5 harness through the J4 housing.
11.	Fish the new harness through the housing from the J5 side. There is a cutout in the rotating wall of the J4 output housing that the harness must be fished through. This is easier if a small tie wrap is placed around the J4 end of the harness for this operation, then removed.

Step	Action
12.	Plug the new harness into the J5 slave controller, then re-attach the J5 slave controller to the J5 side wall.
13.	The J5 and J6 slave controllers can be replaced with this same procedure.
14.	Replace the J5 side cover and other parts. Be sure the encoder battery harness is plugged in to the encoder battery pigtail coming J6 controller battery daisy chain connector.
15.	Recalibrate the robot.

Replacing the J6 Motor Pigtail Harness

Tools Required

- 2.0 mm hex driver
- 2.5 mm hex driver

Spare Parts Required

- J6 Motor and Encoder Pigtail PN PFD0H-MA-00010-X3

Table 2-22: Replacing the J6 Motor Pigtail Harness

Step	Action
1.	Remove the foam side cover from J5, the IO harness bracket, and the J5 cover plate, threading the J6 motor pigtail harness thru the 25 mm bearing.
2.	Remove the J6 cover plate, replace the harness, tie wrap per below, and replace the parts.

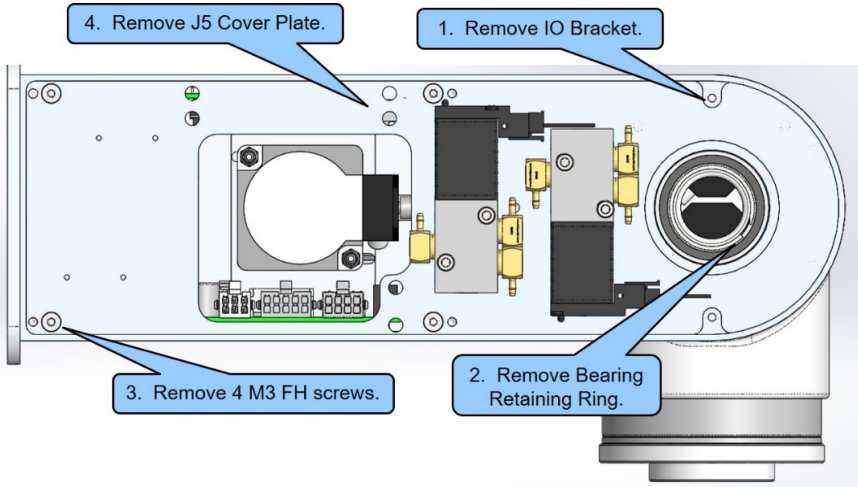
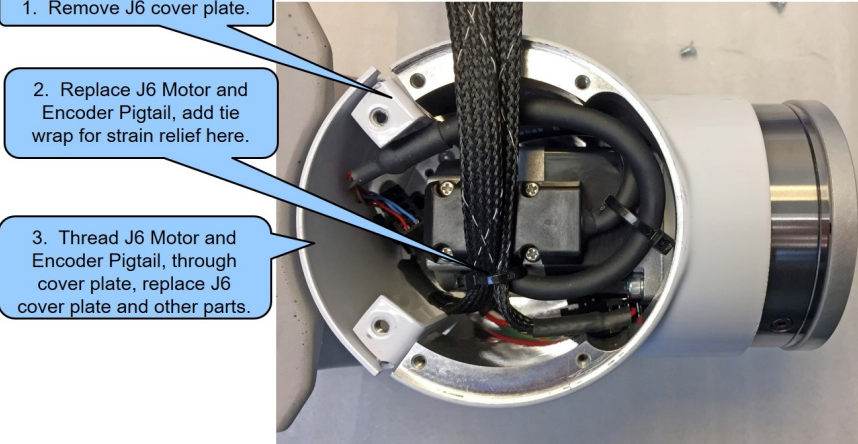
Step	Action
3.	<p>Recalibrate the robot.</p>  <p>4. Remove J5 Cover Plate.</p> <p>1. Remove IO Bracket.</p> <p>3. Remove 4 M3 FH screws.</p> <p>2. Remove Bearing Retaining Ring.</p>
4.	 <p>1. Remove J6 cover plate.</p> <p>2. Replace J6 Motor and Encoder Pigtail, add tie wrap for strain relief here.</p> <p>3. Thread J6 Motor and Encoder Pigtail, through cover plate, replace J6 cover plate and other parts.</p>

Appendices

Appendix A: Conditions of Acceptability

For use only in (or with) complete equipment, when the acceptability of the combination is determined by UL Solutions. The following items should be evaluated to determine the acceptability for use in the end product:

- These devices shall be installed in compliance with the requirements for enclosure, mounting, electrical spacing, and segregation of the end-use equipment.
- The power supply and drives in this report have been evaluated as a system and they shall be installed accordingly. The suitability of any other installation manner shall be determined in the end product application.
- The front face has not been evaluated as an ultimate or part of the overall enclosure.
- Wait 7 minutes after removal of power before servicing equipment for the system capacitance to discharge below a 50 VDC level.
- The input and output connectors are suitable for factory wiring only.
- The spacings have been evaluated to Pollution Degree 2.
- These devices are intended for installation in a Pollution Degree 2 environment.
- These models are suitable for operation in a surrounding air temperature of 40°C.
- This system, power supply and motor drives, are suitable for use on a circuit capable of delivering not more than 1,500 rms symmetrical amperes, 250 VAC maximum.
- The Motor Drive Series 6000 shall be provided with complete instructions as to how to replace the battery cell ending with the statement: "Dispose of used cell promptly. Keep away from children. Do not disassemble and do not dispose of in fire."
- Peak currents indicated in the nomenclature are temporary over-currents only, not intended for use as continuous ratings.

Appendix B: DD6 Product Specifications

General Specification	Range
PERFORMANCE	
Payload	8 kg
Max Cartesian Speed	X/Y Direction, 500 mm/sec Z Direction, 600 mm/sec
Max Joint Speed	J1 - 200°/sec J2 - 600 mm/sec J3 - 360°/sec J4 - 540°/sec
Max Acceleration	5000 mm/sec ² with 6 kg payload
Repeatability	±0.020 mm at tool flange center
RANGE OF MOTION	
Joint 1 (base)	±168°
Joint 2 (Z-axis)	500, 1000, 1420 mm
Joint 3 (Elbow)	+11.5° to +348.5°
Joint 4	±249°
Horizontal Reach	896 mm
COMMUNICATIONS	
General	100 Mb Ethernet, TCP/IP EtherNet/IP RS232 Modbus/TCP
Operator Interface	Web-based operator interface
Digital I/O	12 inputs, 8 outputs at base of robot Optically isolated, 24 V @ 100 ma Remote I/O available
FACILITIES	
Power	90 to 264 VAC, auto selecting, 50-60 Hz 70-175 watts typical operation DC power option available

General Specification	Range
Pneumatics	Two 6 mm airlines provided for end-of-arm-tooling 4.9 bar max (71 PSI) Flow rate of 70 L/min (2.5 SCFM)
E-Stop	Dual channel
Controller Mounting	Embedded into robot base
Air Lines	Two, 3.2 mm OD, 1.6 mm ID Max pressure 500 kpa (75 PSI)
Weight	44 kg (500 mm Z-axis) 53 kg (1000 mm Z-axis) 63 kg (1420 mm Z-axis)
Noise Level	< 50 dB(A)
SOFTWARE	
Programming	Guidance Motion (web interface) Guidance Programming Language (GPL) TCP Command Server (TCS)
Enhanced Functions	Hand Guiding (standard)
PERIPHERALS AND ACCESSORIES	
General	23N Servo Gripper Dual 23N Servo Gripper 60N Servo Gripper Remote I/O (RIO)
Vision	PreciseVision Gripper, 23 N PreciseVision Gripper, 60 N
TEMPERATURE	
Indoor	For indoor use only
Ambient Temperature	0°C to 40°C
Humidity Range	10 to 75%, non-condensing, non-corrosive
Storage and Shipment Temperature	-25°C to +55°C

Appendix C: DD4 Product Specifications

General Specification	Range
PERFORMANCE	
Payload	6 kg
Max Cartesian Speed	X/Y direction, 500 mm/sec Z direction, 600 mm/sec
Max Joint Speed	J1 200°/sec J2 600 mm/sec J3 360°/sec J4 360°/sec J5 200°/sec J6 360°/sec
Max Acceleration	5000 mm/sec ² with 6 kg payload
Repeatability	+/-0.020 mm at tool flange center
RANGE OF MOTION	
Joint 1 (base)	+/- 169.5°
Joint 2 (Z-axis)	500, 1000, 1420 mm
Joint 3 (Elbow)	+11.5° to + 348.5°
Joint 4	+100° to -120°
Joint 5	+/-110°
Joint 6	+/-295°
Horizontal Reach	896 mm
COMMUNICATIONS	
General	100 Mb Ethernet, TCP/IP EtherNet/IP RS232 Modbus/TCP
Operator Interface	Web-based operator interface
Digital I/O	12 inputs, 8 outputs at base of robot Optically isolated, 24 V @ 100 ma Remote I/O available
FACILITIES	

General Specification	Range
Power	90 to 264 VAC, auto selecting, 50-60 Hz 70-175 watts typical operation DC Power Option Available
Pneumatics	Two 6 mm airlines provided for end-of-arm-tooling 4.9 bar max (71 PSI) Flow rate of 70 L/min (2.5 SCFM)
E-Stop	Dual Channel
Controller Mounting	Embedded into robot base
Air Lines	Two, 3.2 mm OD, 1.6 mm ID, max pressure 500 kpa (75 psi)
Weight	46 kg (500 mm Z-axis) 55 kg (1000 mm Z-axis) 65 kg (1420 mm Z-axis)
SOFTWARE	
Programming	Guidance Motion (web interface) Guidance Programming Language (GPL) TCP Command Server (TCS)
Enhanced Functions	Hand Guiding (standard)
PERIPHERALS AND ACCESSORIES	
General	Remote I/O (RIO)
Vision	PreciseVision Gripper, 23 N PreciseVision Gripper, 60 N
TEMPERATURE	
Indoor	For indoor use only
Ambient Temperature	0°C to 40°C
Humidity Range	10 to 75%, non-condensing, non-corrosive
Storage and Shipment Temperature	-25°C to +55°C

Appendix D: Environmental Specifications

The PFDD Robots must be installed in a non-condensing environment with the specifications from the table below.

Environmental Specifications

General Specification	Range & Features
Indoor use only	
Ambient temperature	4° C to 40° C
Storage and shipment temperature	-25° C to +55° C
Humidity range	10 to 90%, non-condensing
Altitude	Up to 3000 m
Voltage	100-240 VAC +/- 10%, 50/60 Hz
Mains cord rating, min	16AWG, 3 conductor, 10 Amps min
Pollution Degree	2
Approved Cleaning Agents	IPA, 70% Ethanol/30% water, H2O2 Vapor up to 1000 ppm
IP Rating with Tape Seal Option	52
IP Rating without Tape Seal Option	11
IK Impact Rating	IK08: 5 Joule

Appendix E: Spare Parts List

NOTE: Email support_preciseflex@brooksautomation.com for help replacing spare parts.

Reference - the serial number format is:

- FD0-yymm-XY-zzzzz
- Yy – year
- Mm – month
- X – controller rev
- Y – robot rev
- Zzzzz – unique number

Spare Parts List

Description	Part Number
Absolute Encoder Battery	G1S0-EC-X0007
J2 Stage 1 Belt	PFD0-MC-X0006
J2 Stage 2 Belt 500 mm	PFD0-MC-X0003
J2 Stage 2 Belt 1000 mm	PFD0-MC-X0003
J2 Stage 2 Belt 1420 mm	PFD0-MC-X0003
J2 400 W Motor	PFD0-MA-00053
J4 Stage 1 Belt	PFD0-MC-X0050
J4 Stage 2 Belt	PFD0-MC-X0051
Main Controller with Complex Kinematics License	PFD0-EA-00001-3
Slave Controller GSBP 20A with motor connector pigtail and thermal pad for Z	G6X0-EA-01202-3A
Slave Controller GSBP 20A no thermal pad	G6X0-EA-00202-3A
Slave Controller GSBP 10A single ended for 23 N grip	G6X0-EA-00101-3A
J4 400 W Motor for PFDD4 with pulley	PFD0-MA-00029
Assy, J4, HD PFD0	PFD0-MA-00041
Assy, J5 & J6, HD, PFD0	PFD0-MA-00046
PF400 23N Servo Gripper with Spring, without fingers	PF0S-MA-00001-2
J3 Clockspring Harness	PFD0-MA-00021-X2
J4 to Gripper Harness in PFDD4	PFD0-MA-00017
J4 to J5 Harness in PFDD6	PFD0-MA-00016
J5 to J6 Harness in PFDD6	PFD0-MA-00017
J6 Motor and Encoder Pigtail	PFD0-MA-00010-X3
24VDC Supply	PS10-EP-24150
48VDC Motor Supply	PS10-EP-481000
Slip Ring Harness Assembly, 23 N Spring Gripper	PF04-MA-00010-E7
Solenoid Valve	PF05-MC-X0001

Description	Part Number
Energy Dump Resistor Assembly	PFD0-MA-00024
O-Rings for Front Cover dowel pins (2)	0000-HC-X0051

Appendix F: Preventative Maintenance

Every one to two years, perform the following preventative maintenance procedures. For robots that are continuously moving 24 hours per day, 7 days a week at moderate to high speeds, a one-year schedule is recommended. For robots with low duty cycles and low to moderate speeds, these procedures should be performed at least once every two years.

Preventative Maintenance

	Procedure If Problem Detected
Check all belt tensions.	Re-tension if necessary.
Check air harness tubing in elbow if present, and theta axis for any wear.	Replace if necessary.
Check second stage (long) Z belt for any squeaking.	If noisy, add thick grease to front and rear edge of belt if necessary. (Shell 222 XP or similar). Z timing belt can get stiffer over time (2-3 years) and occasionally start squeaking against pulley flanges.
Check if front cover is rattling.	If so, check .125 in ID by .062 in thick O rings on dowel pins in base plate under front cover for any deterioration and replace if necessary.
Replace slip ring in DD4 if present.	For units with 23 N electric replace the slip ring every third inspection test, or 20,000 hours of operation.

Appendix G: Belt Tensions, Gates Tension Meter

In some cases, it may be desirable to confirm the belt tension of one of the axes in the robot. If it appears a belt tension is not correct, the tension can be checked with a Gates Sonic Tension Meter, Model 507C or 508C.



Using the Tension Meter

Step	Action
1.	Turn on the power.
2.	Click Mass and enter the belt mass from Appendix G .
3.	Click Width and enter the belt width from Appendix G .
4.	Click Span and enter the belt free span from Appendix G .
5.	Click Select to record the data.
6.	Click Measure to take a tension reading.
7.	Place the microphone near the belt, typically within 3 mm or so. Gently pluck the belt so that it vibrates. The tension meter will calculate the belt tension from the acoustic vibrations and display the tension in Newtons. Compare the tension to the table below. Adjust the belt tension preload screws if necessary.

PreciseFlex DD Belt Tensions

Axis	Mass (g)	Width (mm)	Span (mm)	Tension (N)
Z-Axis S1	4.1	12	120	70 - 90
Z-Axis S2 - 500	4.8	14	620	400 - 420
Z-Axis S2 - 1000	4.8	14	1120	400 - 420
Z-Axis S2 - 1420	4.8	14	1540	400 - 420
J4 S1	2.8	15	180	60 - 70
J4 S2	4.1	25	176	100 - 120
J5	2.8	9	146	45 - 60

Appendix H: System Diagram and Power Supplies

The robot has a 24 VDC and 48 VDC power supply located in the Z column. The power supplies have both over-current and over-voltage protection and are CSA, UL, and CE certified. The robot controller and electric gripper are powered by the 24 VDC supply. The main robot motors are powered by the 48 VDC supply. The 48VDC supply is protected against over voltage bus pump up by an energy dump circuit, which connects a 75-Watt dump resistor located in the base housing across the 48 VDC supply output when the voltage reaches 56 Volts, and disconnects the dump resistor when the voltage drops to 52 Volts. This protects the power supply during high speed motor deceleration when the motor generates Back EMF voltage that adds to the power supply voltage.

DC power is routed from the power supplies to the controllers through a ribbon cable which also contains three twisted pairs for RS485 (one pair) and 100 BaseT Ethernet (two pairs).

Twelve digital input and eight digital output signals from the main robot controller are available in the 25-pin Dsub on the connector panel in the base. The twelve digital output signals can be individually configured as either sourcing or sinking by software settings in the web interface. The eight digital input signals can be configured as either sourcing or sinking individually and the twelve digital inputs can be configured as sourcing or sinking in blocks of four by software settings in the web interface. See the section on IO.

It is necessary to wire an Emergency Stop Button to the controller. This button may be wired in series with other emergency stop contacts. The E-Stop signals are available in the Manual Control Pendant 9-pin DSub connector that is mounted on the Facilities Panel. See the Hardware Reference section of this manual for detailed information on the E-Stop signals. The robot is shipped with a jumper that completes the dual E-Stop circuits.

The cable from the brake release button under the shoulder plugs into the amplifier board for the Z-axis motor on the back of the Z column. This button provides a ground return from the Z column brake to ground bypassing the transistor that performs this function under computer power so that the brake can be released manually without motor power being enabled, as long as 24 VDC is turned on. Care should be taken to support the links of the robot when this button is pushed as the links weigh 14 kg and will drop under gravity when this button is pushed.

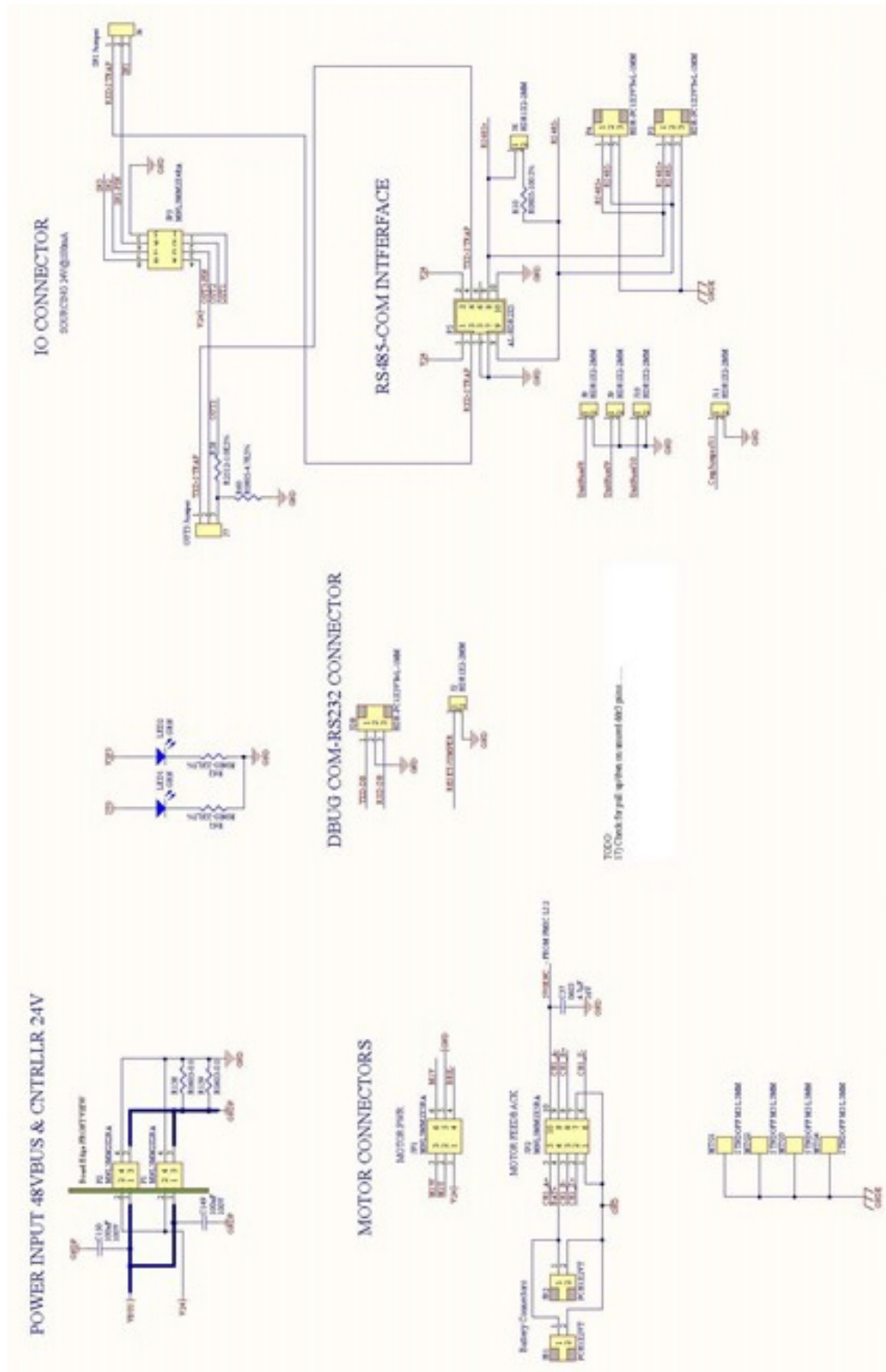

Joint Axis Controller Connectors

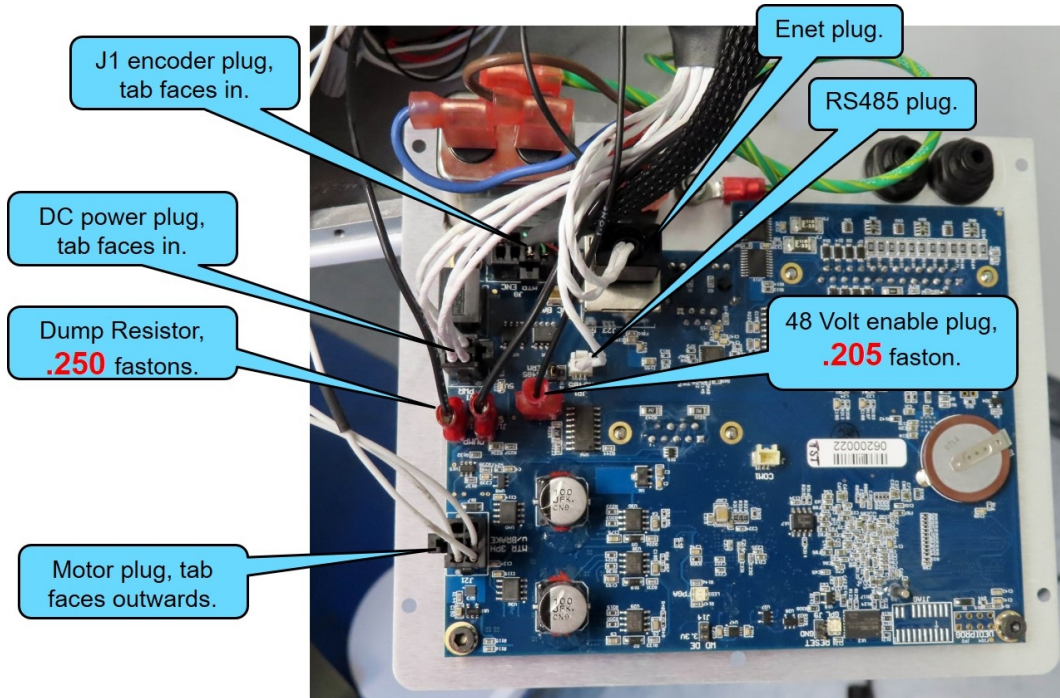

Base Controller Connectors

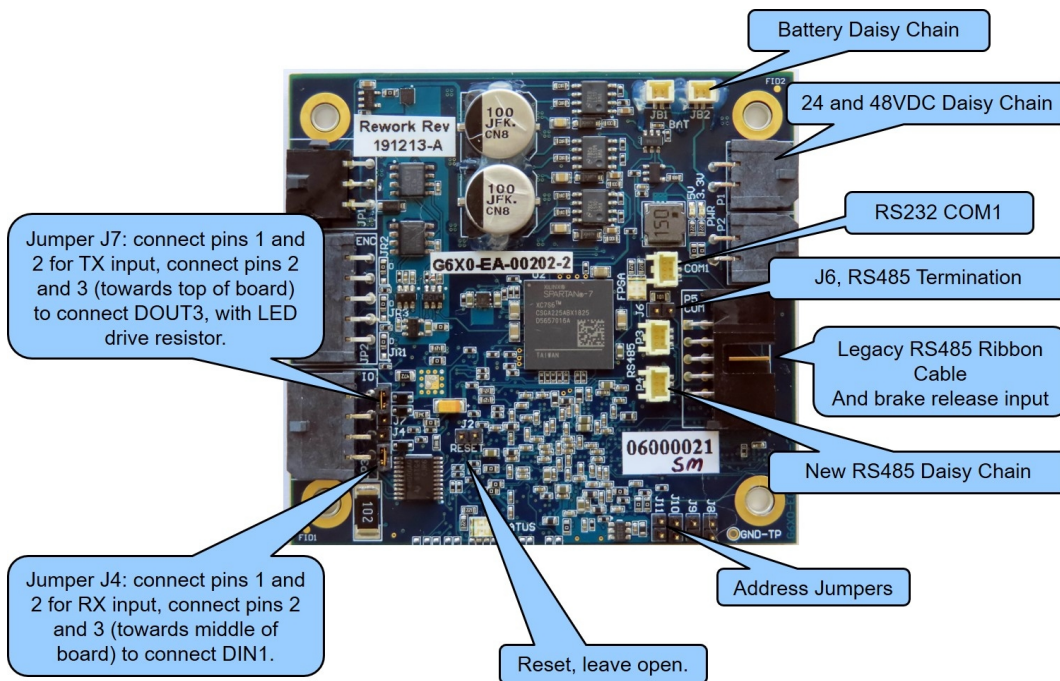

Gripper and Joint Axis Controller Connectors

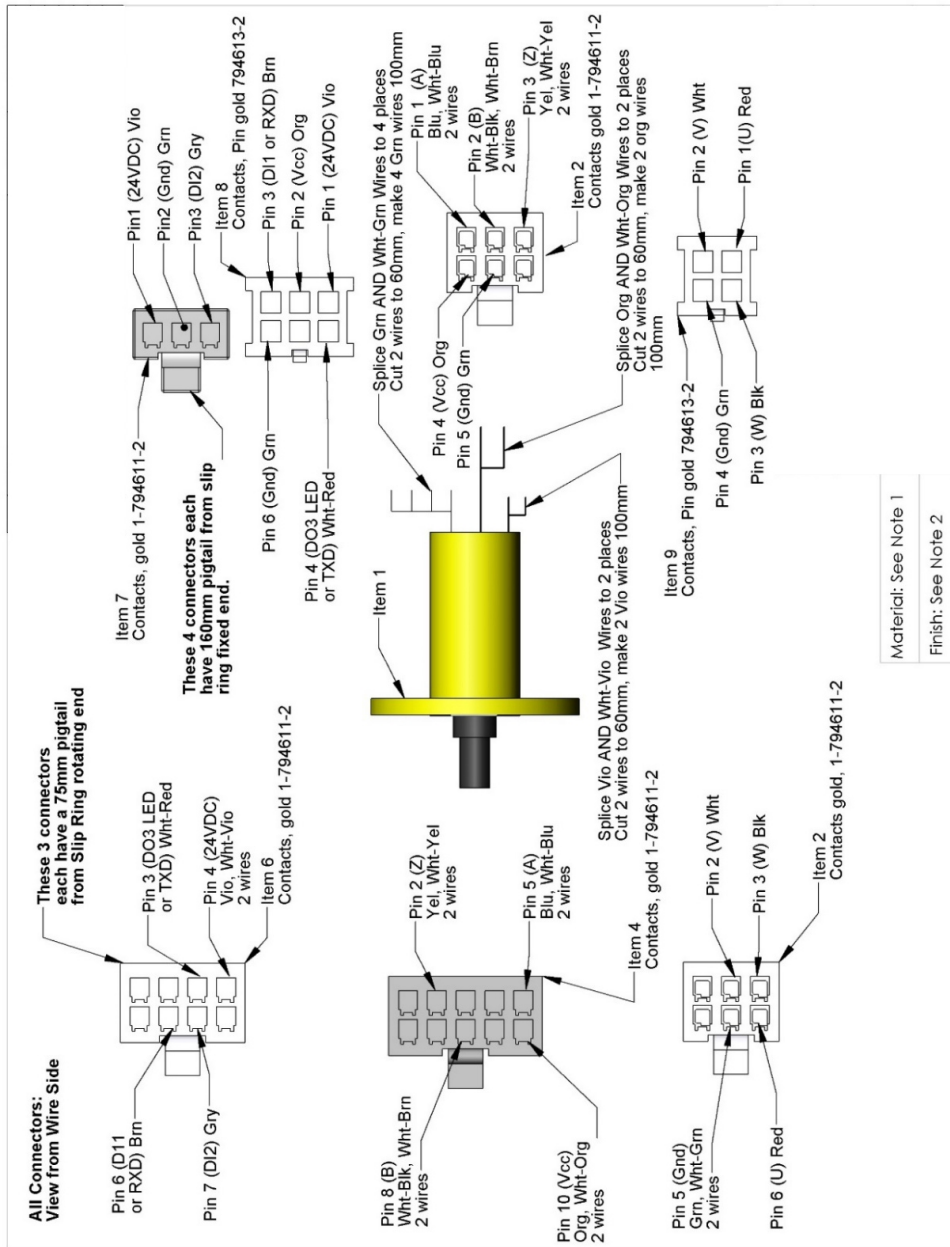

Slip Ring for 23N Gripper, Ass., Harness with Sensor

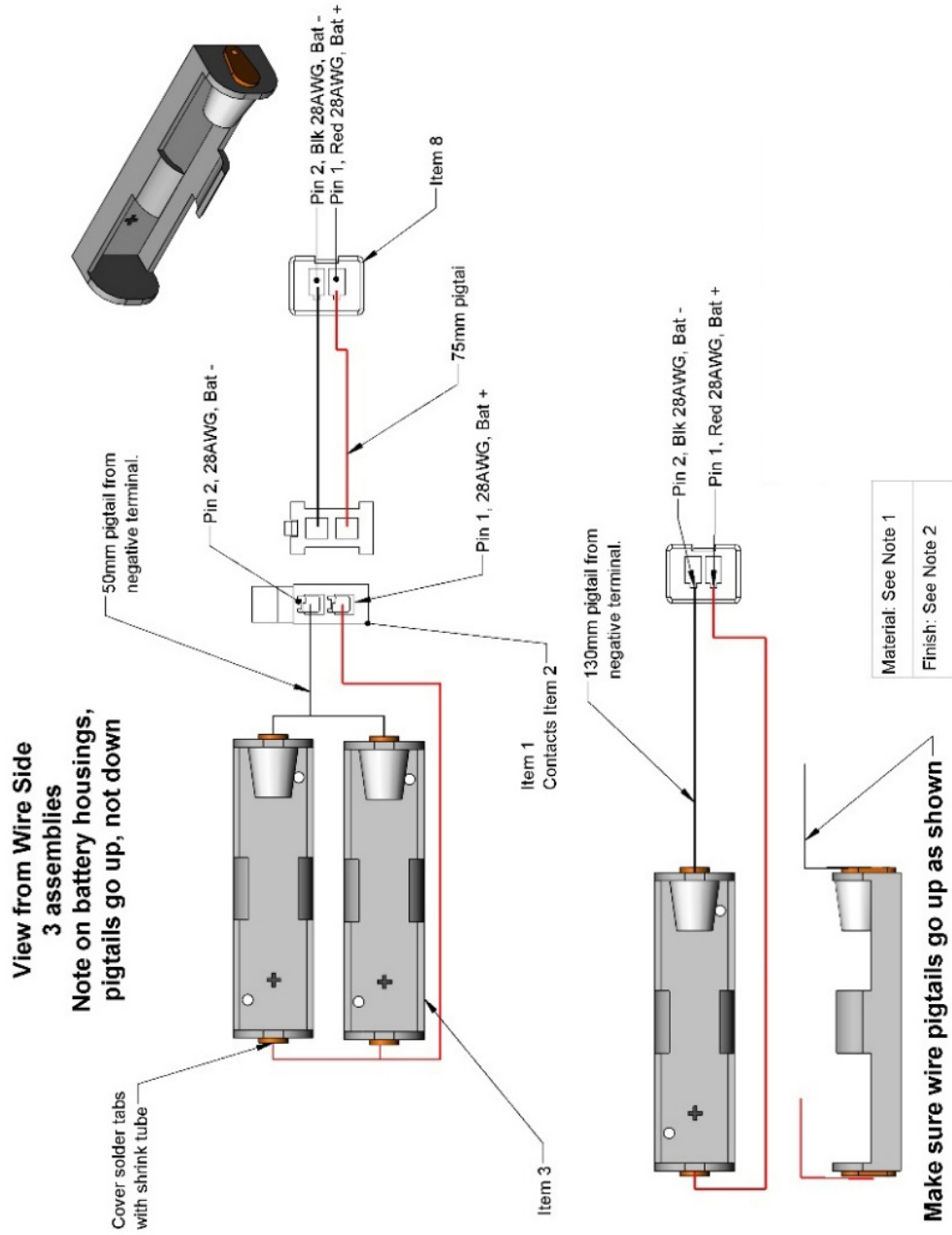

Assy., Battery Holders, AA, BCAAL, PFDO

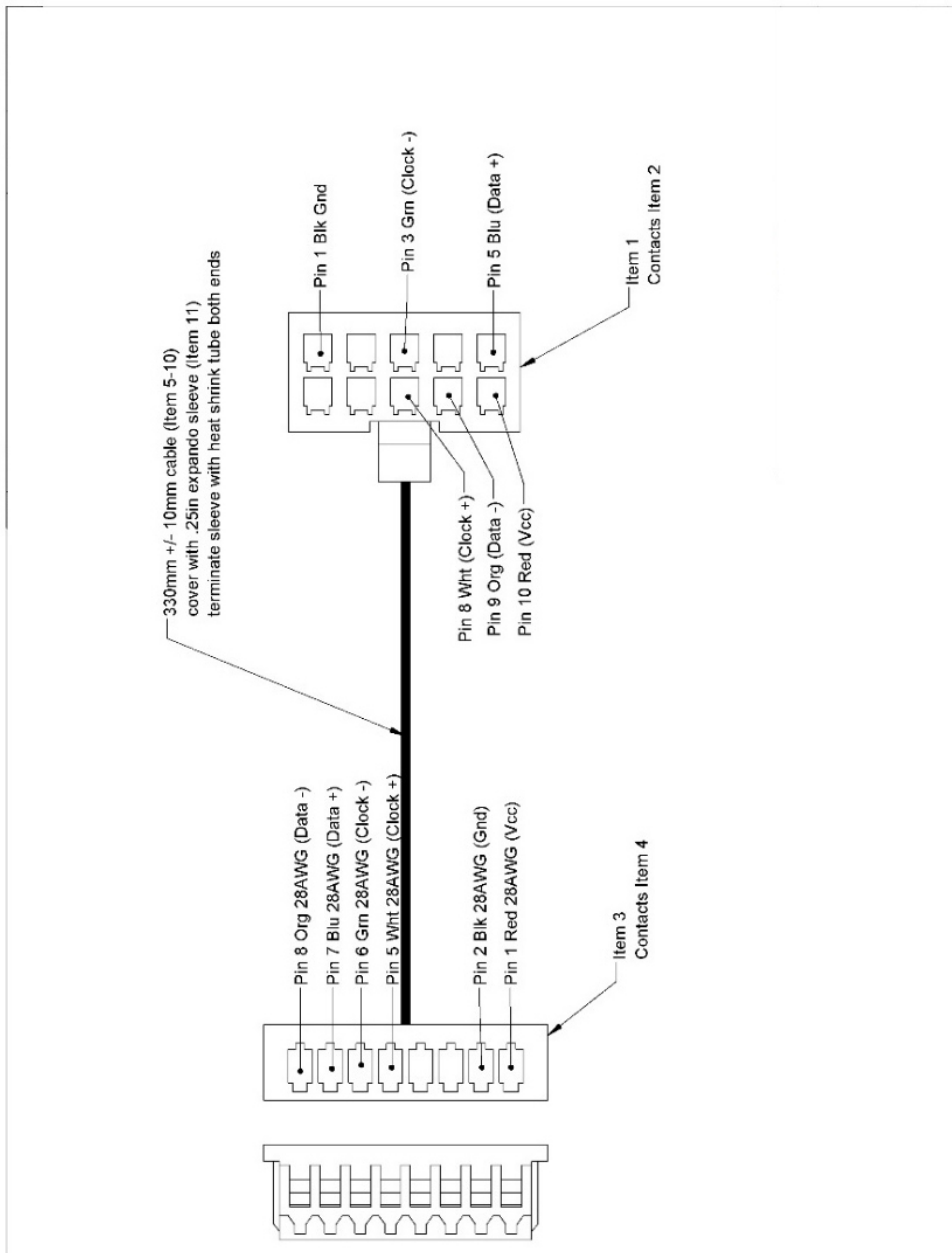

Harness, J1 Renishaw Encoder, PFDO

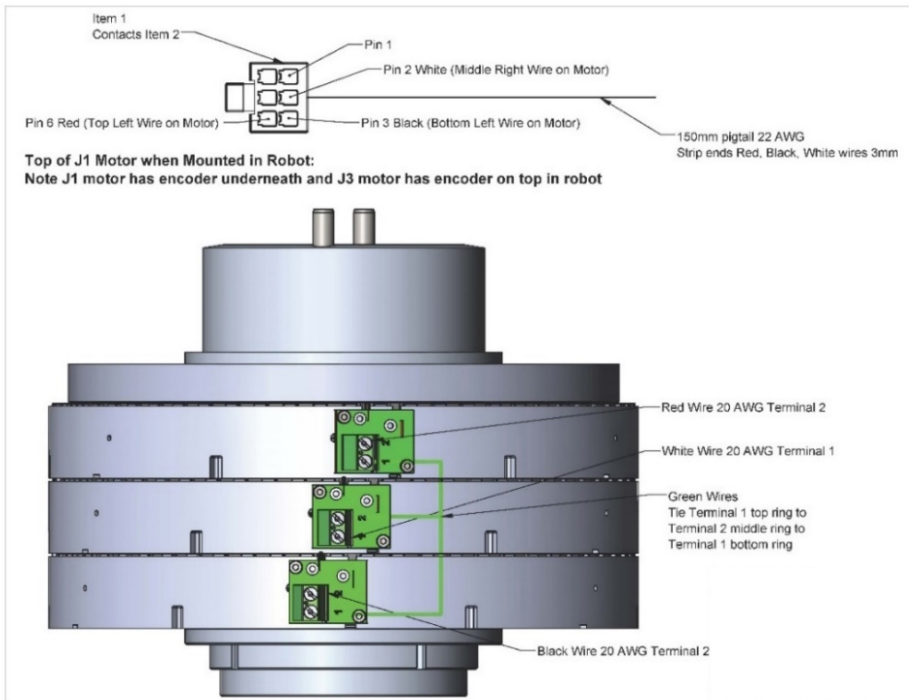

Harness, Motor Pigtail, J1, J3, PFDO

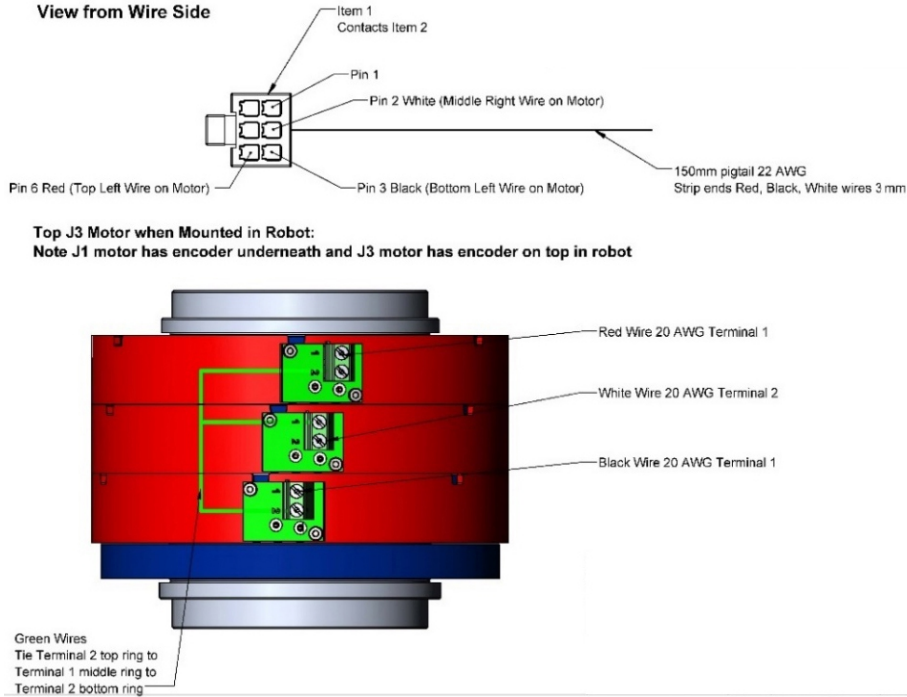

Harness, Motor Pigtail, J1, J3, PFDO

View from Wire Side

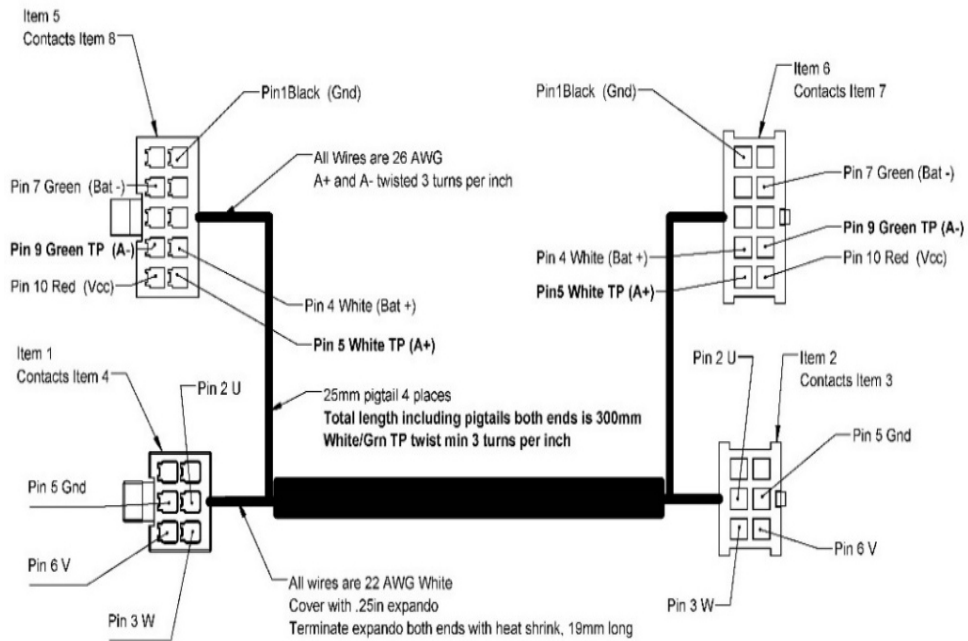

Motor and Encoder Pigtails, J6 PFDO

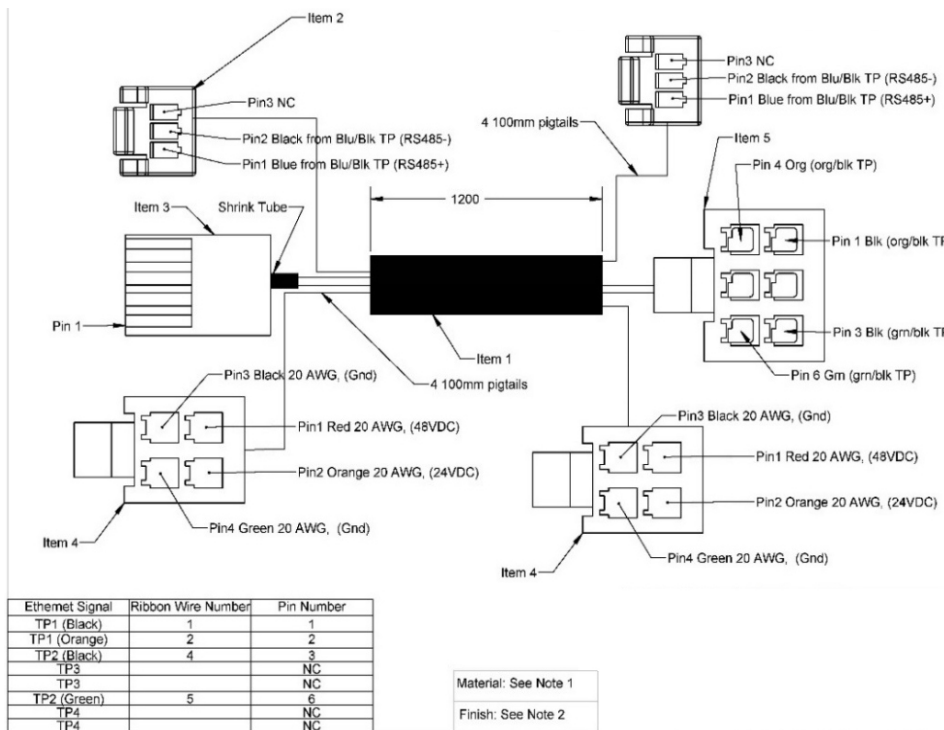

Harness, Signal and DC Power, Base, PFDO

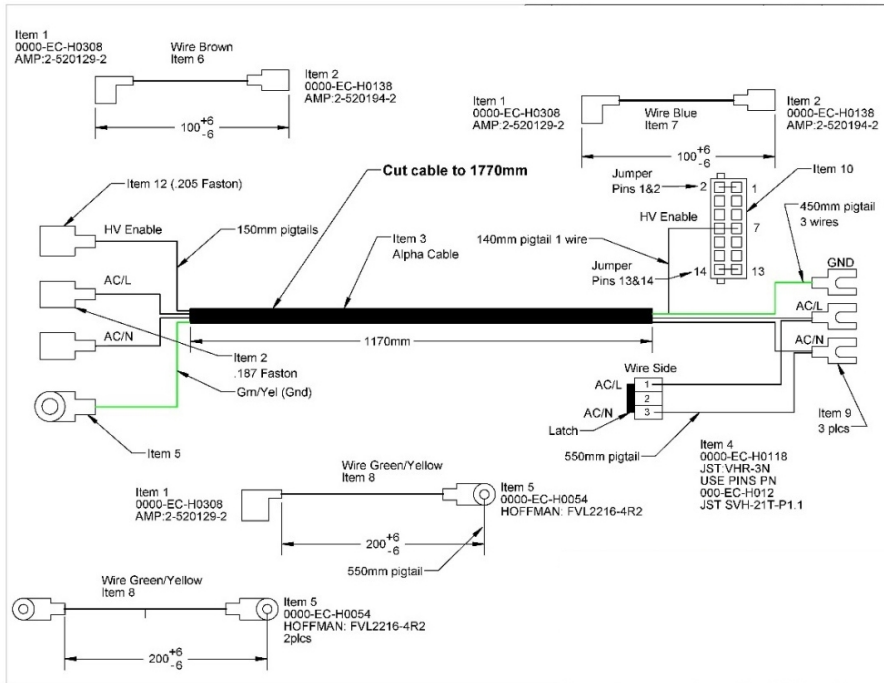

Harness, AC Power, PFDO

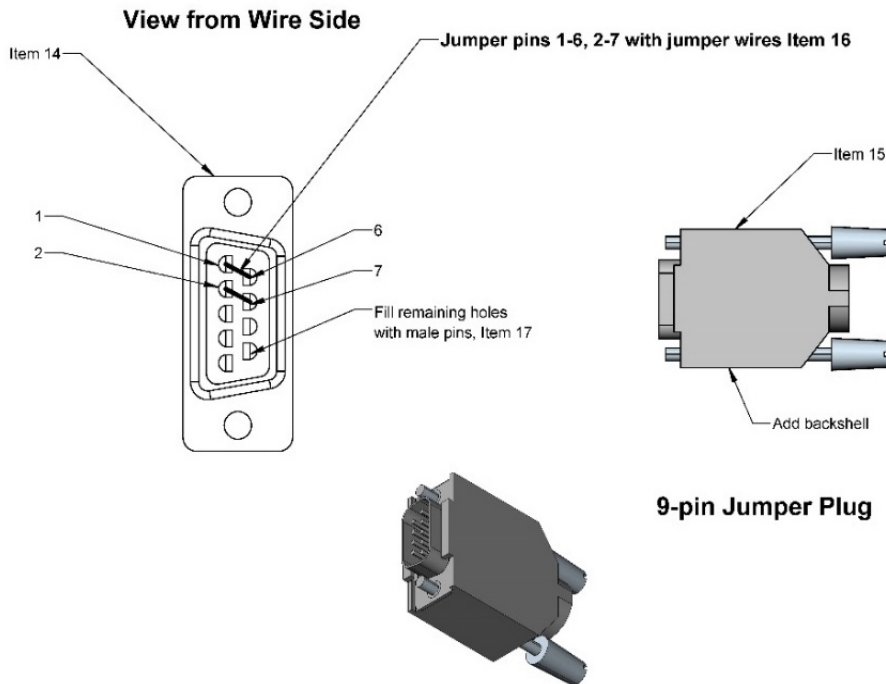

Harness, AC Power, PFDO

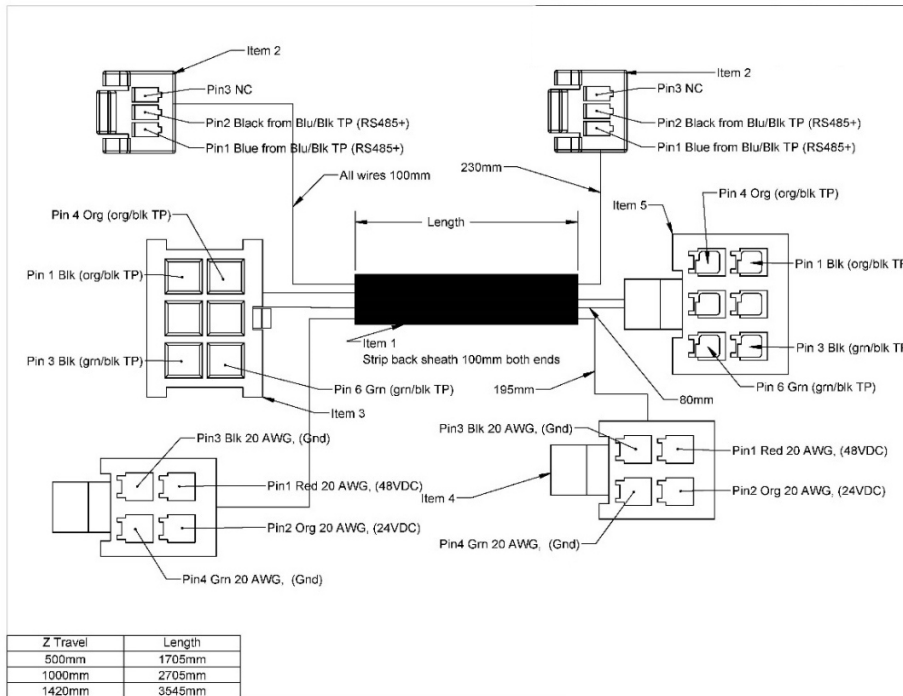

Harness, Column and Inner Link, PFDO

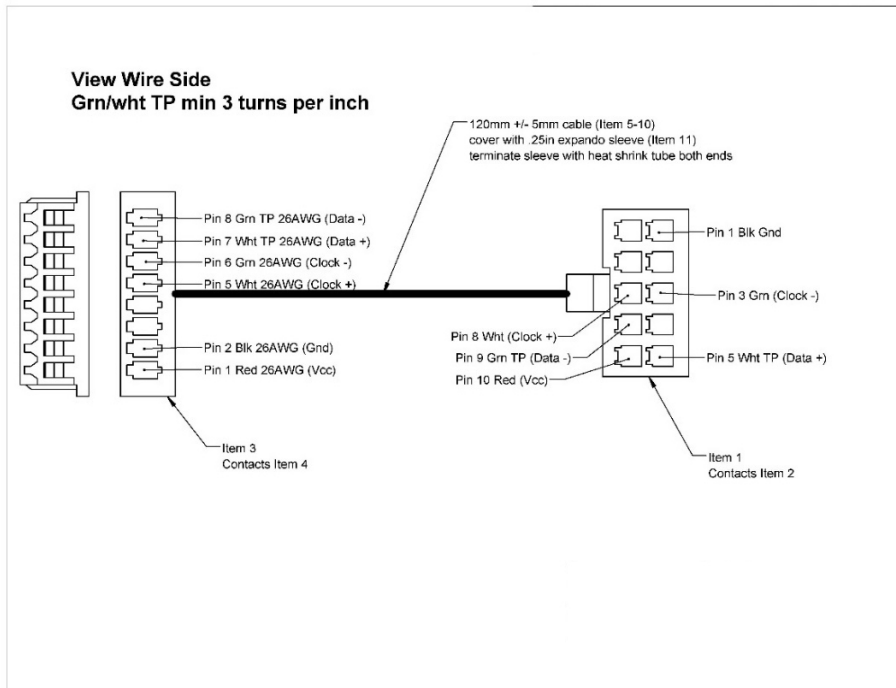

Harness, J3 Renishaw Encoder, PFDO

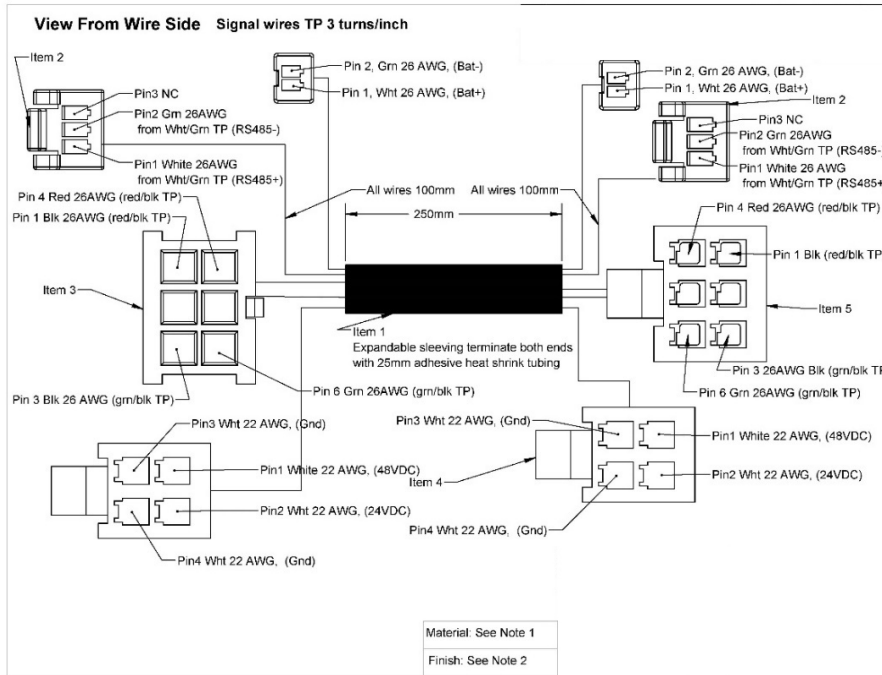

Harness, J4 to J5, PFDO

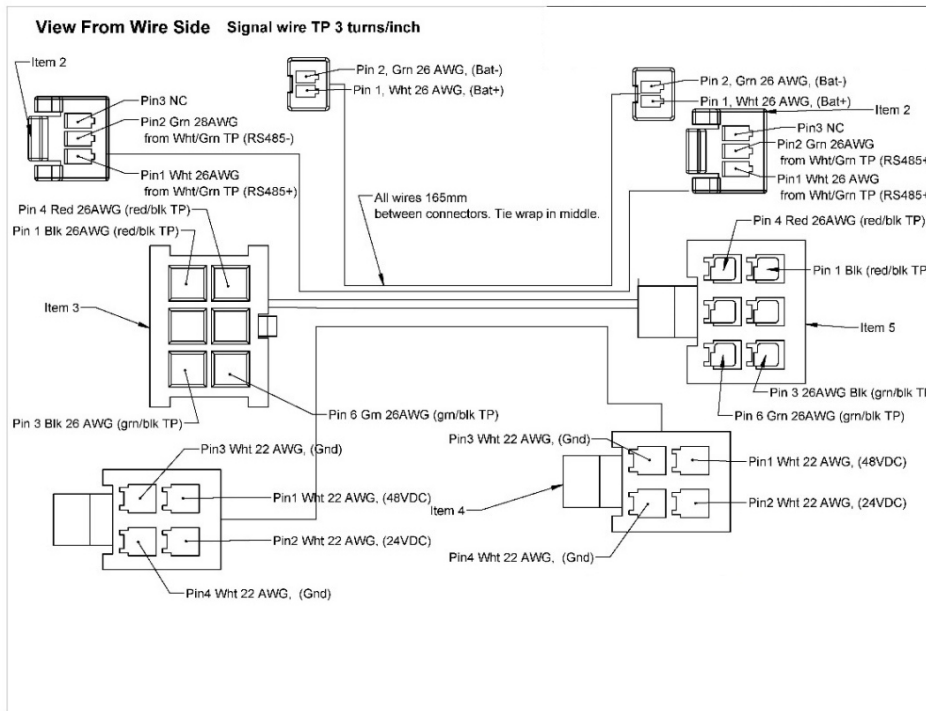

Harness, J5 to J6, PFDO

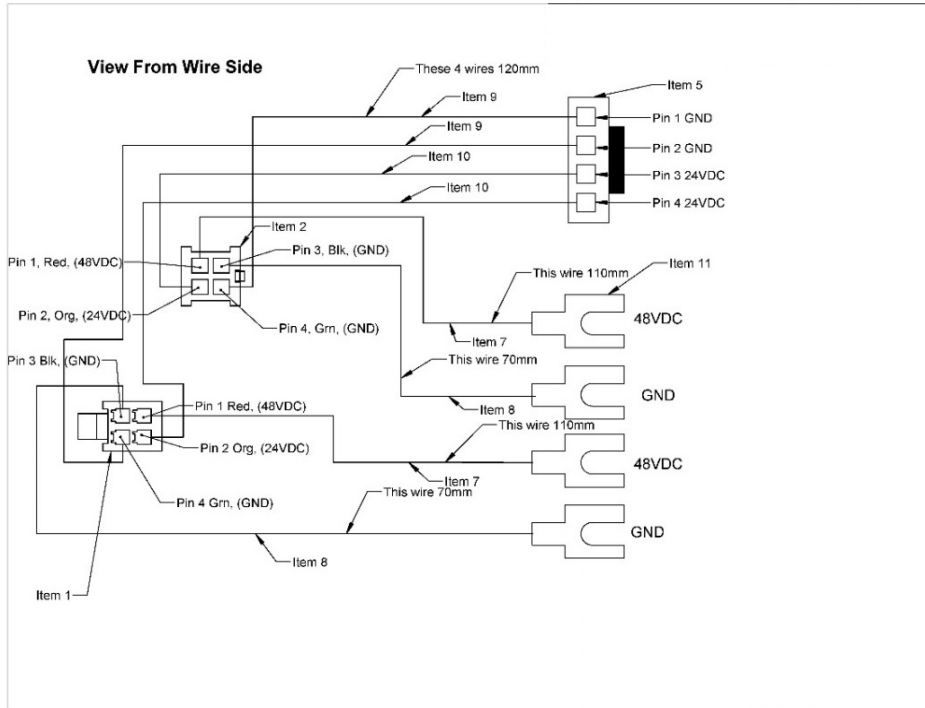

Harness, DC Interconnect, PFDO

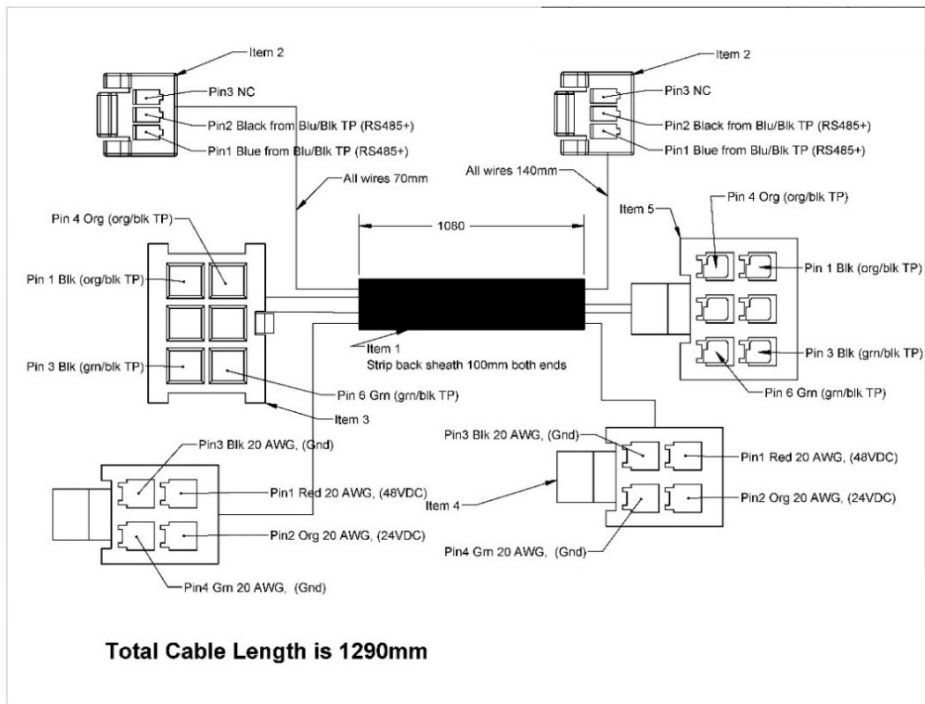

Harness, J3 Clockspring, PFDO

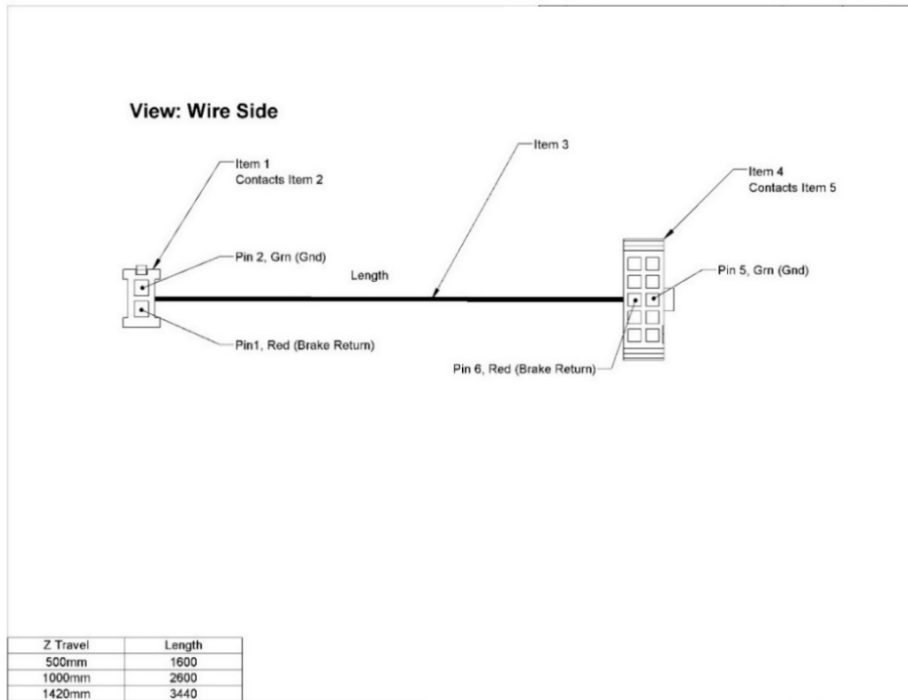

>Harness, Brake Release Cable Extension, PFDO

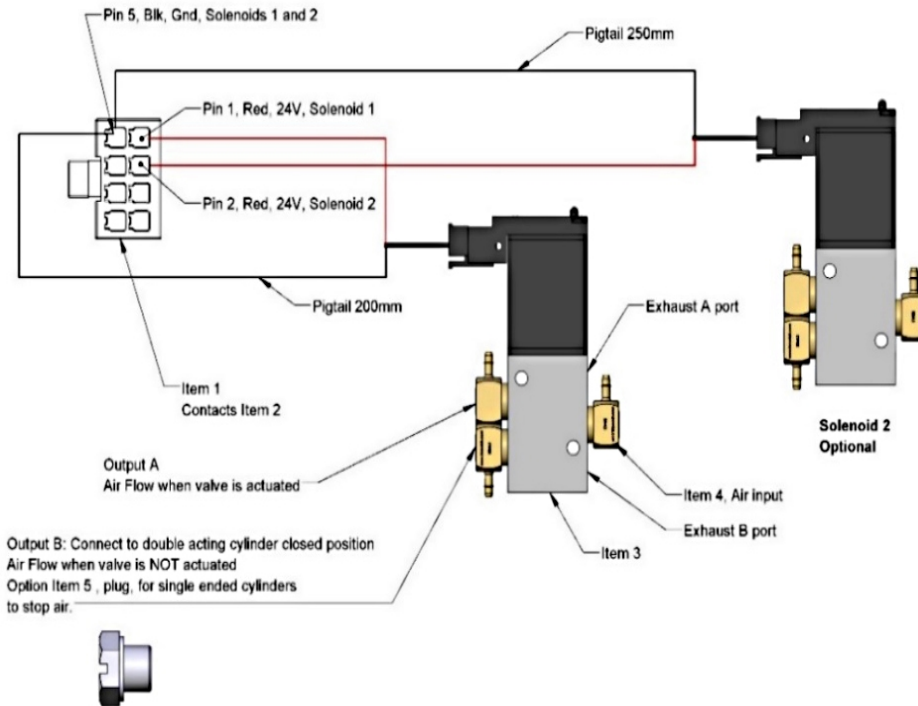

Harness, Single and Dual Valve, PFDO

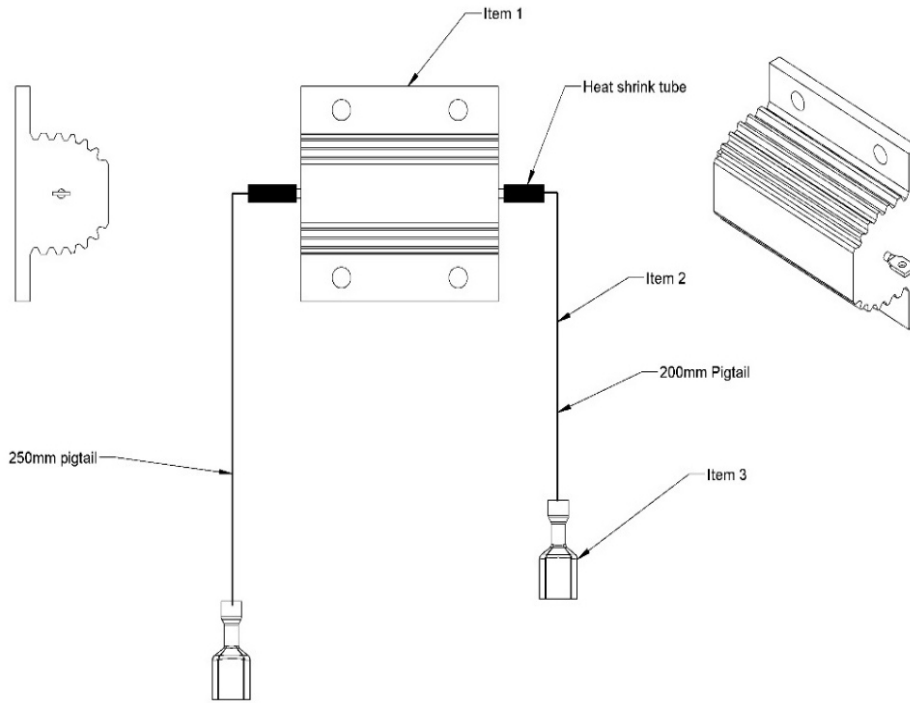

Harness, Dump Resistor with Pigtail, PFDO

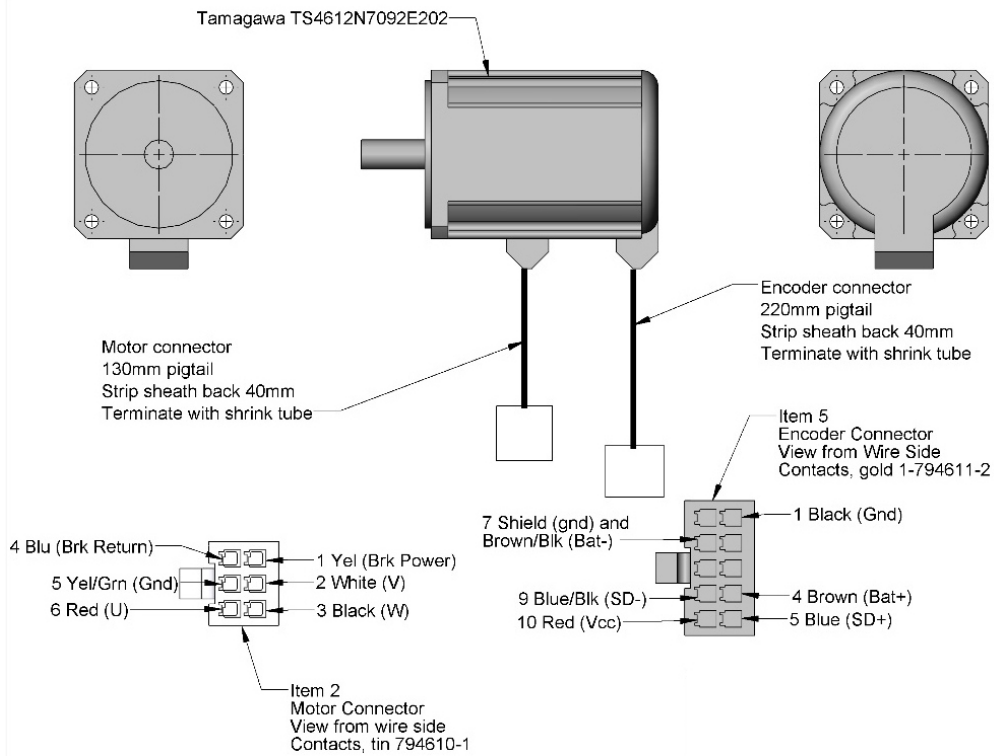

Assy, J2 Motor with Pigtail, PFDO

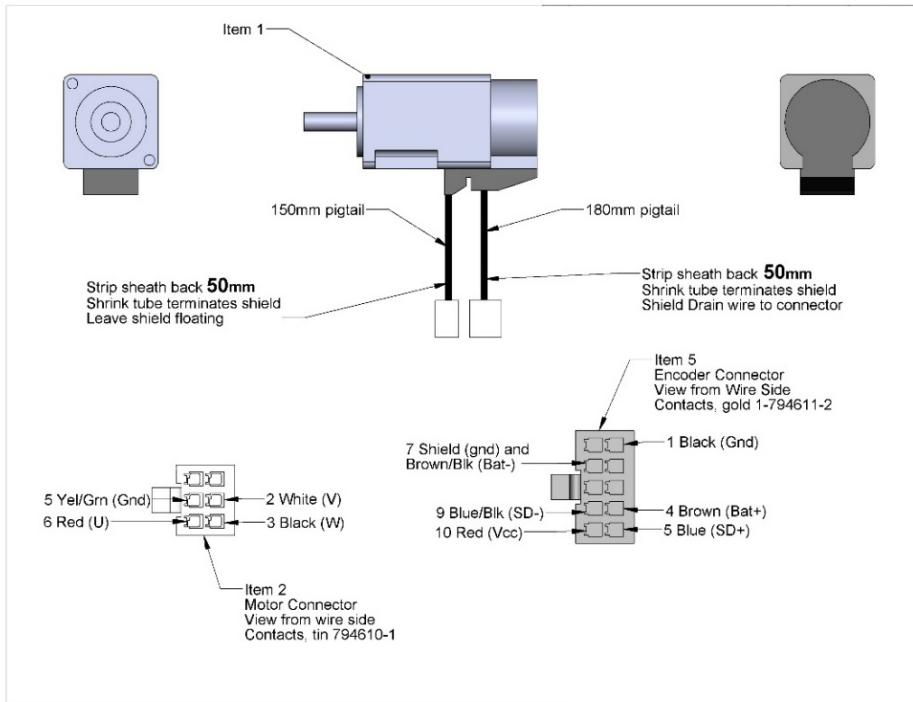

Assy, J4 Motor with Pigtail, 4-axis, PFDO

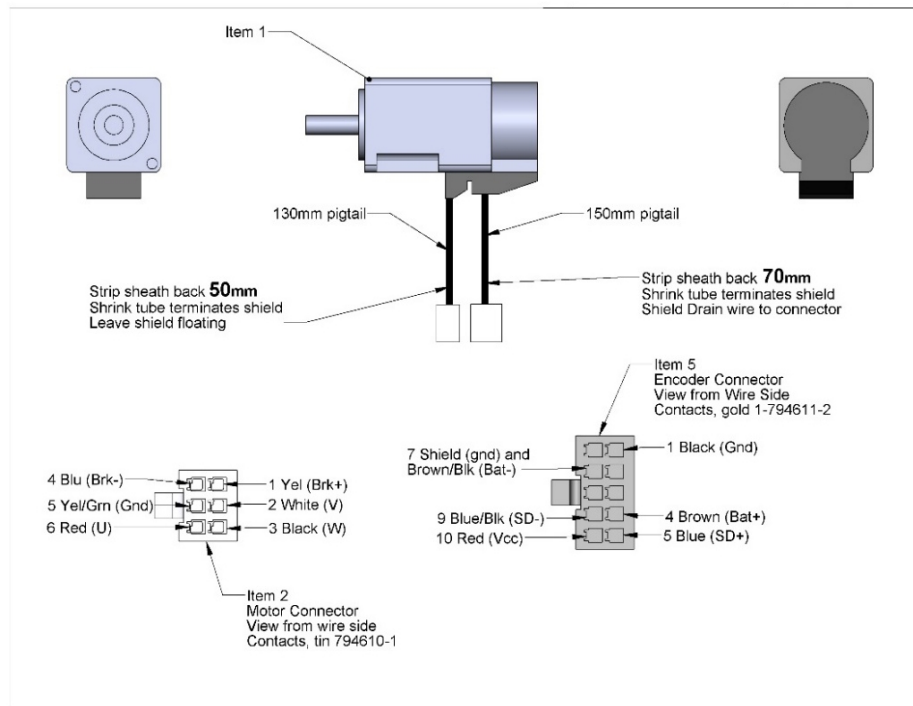

Assy, J4 Motor with Pigtail, 6-axis

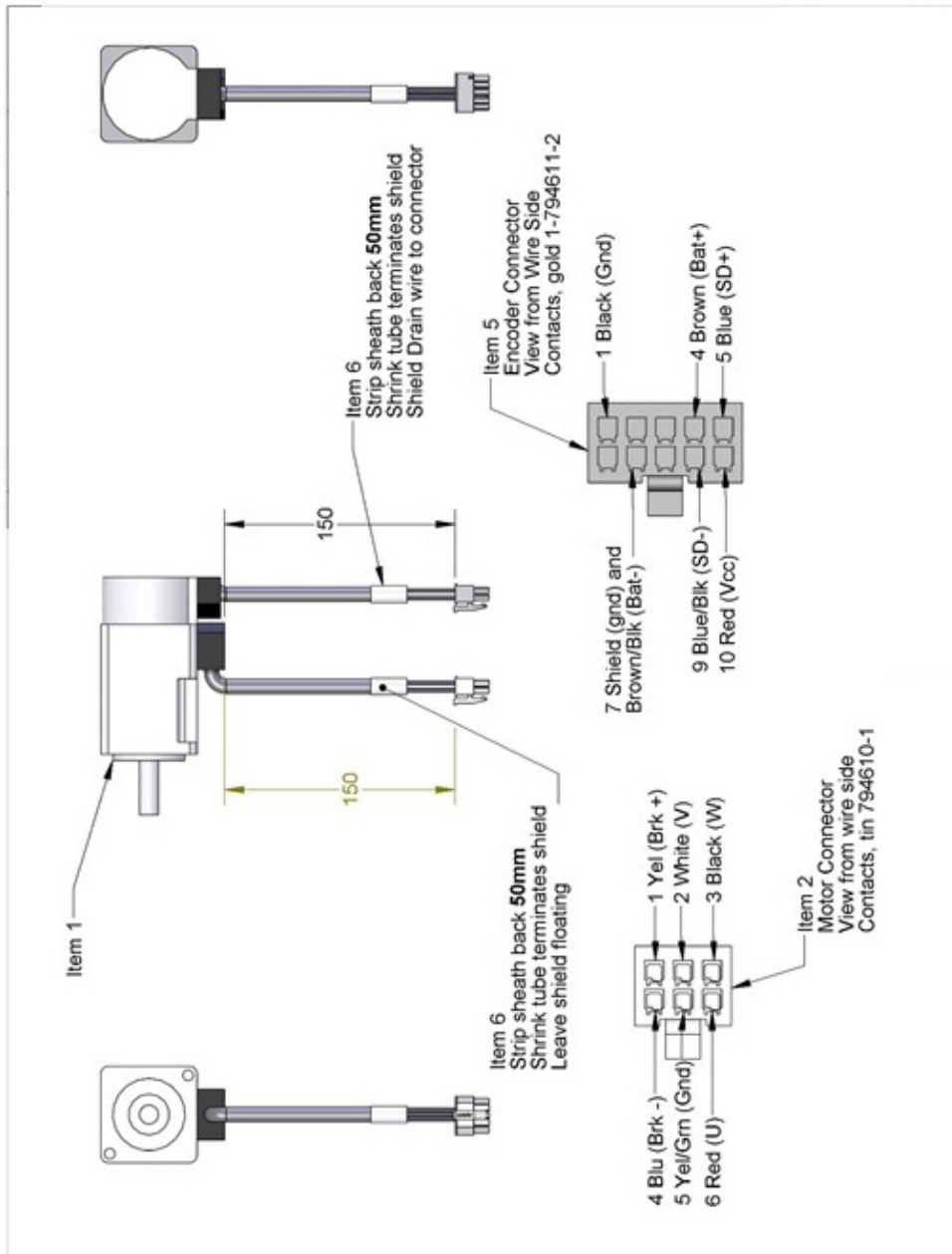

Wiring for J5, J6 motors, 6-axis PFD0(Note J6 motor is 50WT, no brake)

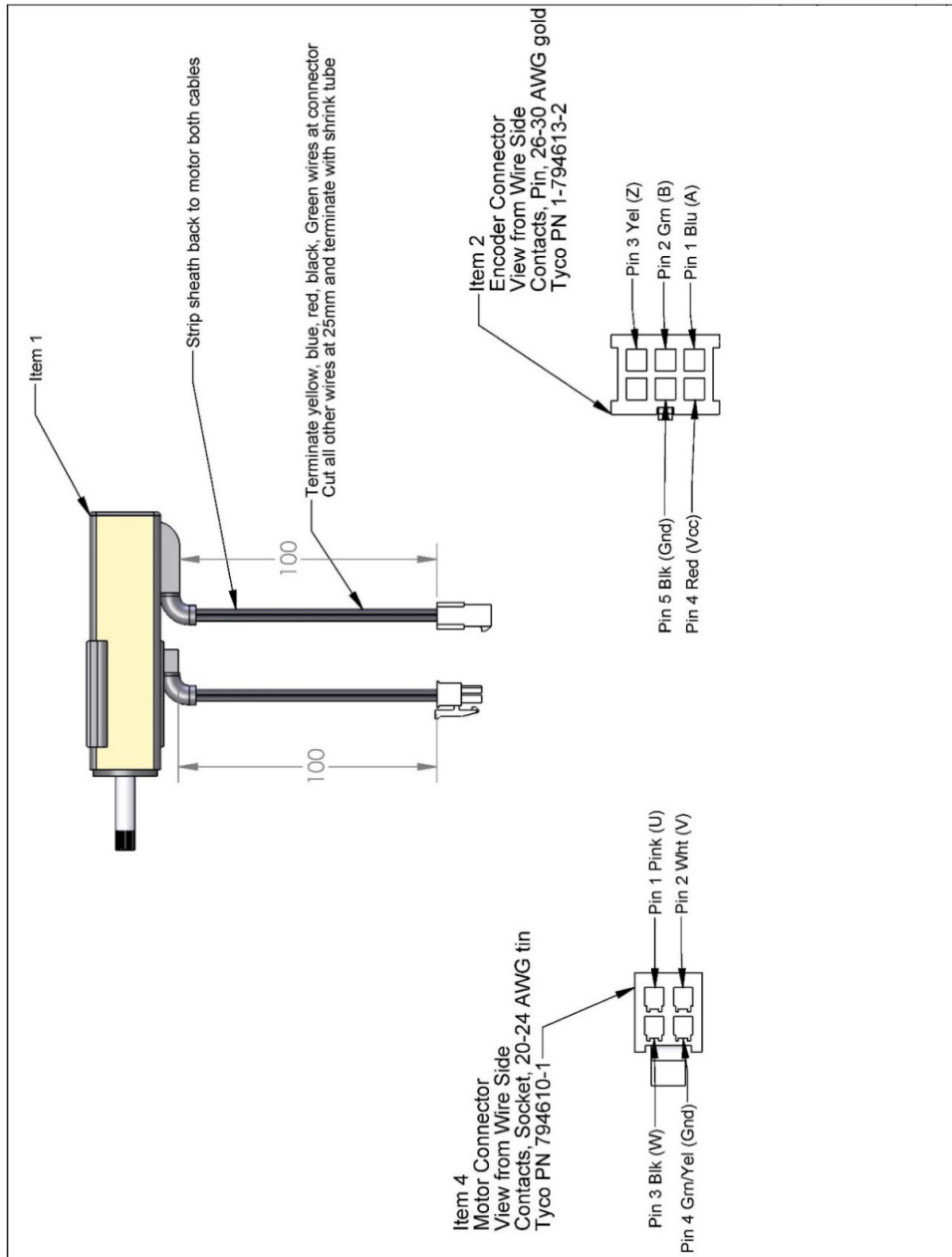

Assy, Gripper Motor with Pigtail

Appendix I: Safety Circuits for PFDD Robots

14-Jun-19	PFDD Robots								
Safety Circuit	Start up Test :	Redundant	Continuous Test	Diagnostic Coverage	MTTFd, Years	Power Off On Failure	PL	Category Safety	
Estop	Yes	Yes	No	99%	100	Yes	d	3	Notes (PF3400t has redundant Estop and 48V power supply enable) Startup test forces Estop, checks 48V power disable, zero amp current Dual Estop circuits turns off amp enable and PWM Dual Estop circuits turns off 48V power Stopping robot with hand turns off amp enable, PWM and 48V
Encoder Feedback	Yes	No	Yes	90%	58	Yes	d	3	Startup test checks encoder communication, prevents mtr power if fault Serial update at 8Khz w checksum, comm check, accel check Counter embedded in position word to confirm CPU read from FPGA
CPU Monitor	Yes	Yes	Yes	99%	100	Yes	d	3	Startup test forces CPU WD low, checks 48V power disabled Independent dual watchdog timers turn off amp enable, PWM and 48V Processor on safety board monitors main CPU. Disables 48V if failure.
Position Envelope Error	Yes	Yes	Yes	90%	57	Yes	d	3	Startup test checks encoder communication, prevents mtr power if fault Serial update at 8Khz w checksum, comm check, accel check SW watchdog in servo loop turns off amp enable, PWM and 48V Counter embedded in position word to confirm CPU read from FPGA
Power amp Fault	Yes	Yes	Yes	90%	100	Yes	d	3	Startup test confirms zero current when 48V enabled Excess current to ground or phase to phase triggers shutdown in 10 usec Saturated PID current command triggers shutdown in .050 sec Shorted transistor just locks up brushless motor
Collab Force Limit	Yes	Yes	Yes	90%	5W	Yes	d	3	Tests 2, 3, 4 above test HW. Motor driven against brake to test 5W current limit. Position envelope error triggers fault, turns off power at amp and 48V Current saturation triggers separate fault, turns off power at amp and 48V Monitor function with WD turns off power at amp and 48V Monitor and CPU WD tested at startup turning off 48V Assymetric current limits limit Z force even with gravity load
Velocity Restrict	Yes	Yes	Yes	99%	93	Yes	d	3	Startup test, sets flag to trigger this error, then resets Checks velocity limit in FPGA in addition to check in CPU servo software
									1. Cat 3 and Cat 3 require startup test before enabling motor power

Safety Circuits for PFDD Robots

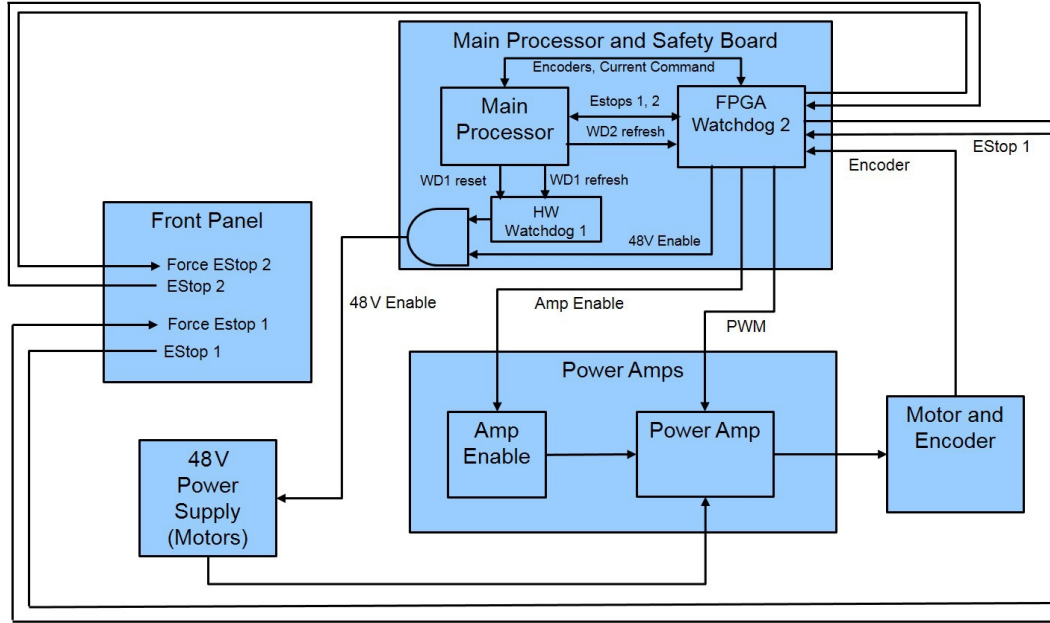

Safety Circuits for PFDD Robots

Appendix J: Example Performance Level Evaluation for the PFDD

Example Workcell description: A PFDD4 moves 100-gram plastic trays from storage racks to an instrument and back to the storage racks. Gripper is an electric parallel jaw gripper with maximum 23 N of gripping force for plastic trays and is spring loaded so it will not drop trays if power fails. Robot motion is programmed with approach point 50 mm above the instrument tray and final motion into instrument is made at 50 mm/sec. Lowest storage rack position is 50 mm above table surface.



Example PF400 Workcell: Courtesy of Biosero

Normal Operator Interaction with robot:

Teaching locations in workcell by hand guiding or teach pendant. Maximum robot forces under manual control from PFDD Table 1 are 105 N. Pausing robot and removing racks from workcell with safety interlocks in workspace. Robot is stopped.

Possible Low Frequency (rare) Interaction with Robot:

Untrained operator reaches into workcell while robot is moving and robot collides with operator. Maximum free space collision force from PFDD Table 1 is 182 N, which is below free space collision for 500 ms maximum of 280 N. Untrained operator reaches into workcell while robot is moving into instrument tray and hand is trapped between robot and instrument tray. From PFDD Table 1 max trapping force in downwards Z direction at 60 mm/sec (10% of max speed of 600 mm/sec) is 77N.

Performance Level: From the above, based on ISO 13849-1:2006:

- S is S1, as possible operator collision forces will not injure operators.
- F is F1 as normal operation does not involve collisions with robot.
- P is P1 as the robot does not make unexpected motions

So PL is “a,” and even a Category B controller is sufficient given the low speeds and small possible collisions forces involved which cannot injure an operator. (See 5.2.3 under [EN/ISO 10218-1:2011](#)).

Appendix K: Table A2 from ISO/TS 15066: 2016

Biomechanical limits

Body region	Specific body area	Quasi-static contact		Transient contact	
		Maximum permissible pressure ^a P_s N/cm ²	Maximum permissible force ^b N	Maximum permissible pressure multiplier ^c P_T	Maximum permissible force multiplier ^c F_T
<i>Skull and forehead ^d</i>	1 <i>Middle of forehead</i>	130	130	not applicable	not applicable
	2 <i>Temple</i>	110		not applicable	
<i>Face ^d</i>	3 <i>Masticatory muscle</i>	110	65	not applicable	not applicable
Neck	4 Neck muscle	140	150	2	2
	5 Seventh neck muscle	210		2	
Back and shoulders	6 Shoulder joint	160	210	2	2
	7 Fifth lumbar vertebra	210		2	
Chest	8 Sternum	120	140	2	2
	9 Pectoral muscle	170		2	
Abdomen	10 Abdominal muscle	140	110	2	2
Pelvis	11 Pelvic bone	210	180	2	2
Upper arms and elbow joints	12 Deltoid muscle	190	150	2	2
	13 Humerus	220		2	
Lower arms and wrist joints	14 Radial bone	190	160	2	2
	15 Forearm muscle	180		2	
	16 Arm nerve	180		2	

^a These biomechanical values are the result of the study conducted by the University of Mainz on pain onset levels. Although this research was performed using state-of-the-art testing techniques, the values shown here are the result of a single study in a subject area that has not been the basis of extensive research. There is anticipation that additional studies will be conducted in the future that could result in modification of these values. Testing was conducted using 100 healthy adult test subjects on 29 specific body areas, and for each of the body areas, pressure and force limits for quasi-static contact were established evaluating onset of pain thresholds. The maximum permissible pressure values shown here represent the 75th percentile of the range of recorded values for a specific body area. They are defined as the physical quantity corresponding to when pressures applied to the specific body area create a sensation corresponding to the onset of pain. Peak pressures are based on averages with a resolution size of 1 mm². The study results are based on a test apparatus using a flat (1.4 × 1.4) cm (metal) test surface with 2 mm radius on all four edges. There is a possibility that another test apparatus could yield different results. For more details of the study, see Reference [5].

^b The values for maximum permissible force have been derived from a study carried out by an independent organization (see Reference [6]), referring to 188 sources. These values refer only to the body regions, not to the more specific areas. The maximum permissible force is based on the lowest energy transfer criteria that could result in a minor injury, such as a bruise, equivalent to a severity of 1 on the Abbreviated Injury Scale (AIS) established by the Association for the Advancement of Automotive Medicine. Adherence to the limits will prevent the occurrence of skin or soft tissue penetrations that are accompanied by bloody wounds, fractures or other skeletal damage and to be below AIS 1. They will be replaced in future by values from a research more specific for collaborative robots.

^c The multiplier value for transient contact has been derived based on studies which show that transient limit values can be at least twice as great as quasi-static values for force and pressure. For study details, see References [2], [3], [4] and [7].

^d Critical zone (*italicized*)

Biomechanical Force & Pressure Limits

Table A.2 (continued)

Body region	Specific body area		Quasi-static contact		Transient contact	
			Maximum permissible pressure ^a p_s N/cm ²	Maximum permissible force ^b N	Maximum permissible pressure multiplier ^c F_T	Maximum permissible force multiplier ^c F_T
Hands and fingers	17	Forefinger pad D	300	140	2	2
	18	Forefinger pad ND	270		2	
	19	Forefinger end joint D	280		2	
	20	Forefinger end joint ND	220		2	
	21	Thenar eminence	200		2	
	22	Palm D	260		2	
	23	Palm ND	260		2	
	24	Back of the hand D	200		2	
	25	Back of the hand ND	190		2	
Thighs and knees	26	Thigh muscle	250	220	2	2
	27	Kneecap	220		2	
Lower legs	28	Middle of shin	220	130	2	2
	29	Calf muscle	210		2	

^a These biomechanical values are the result of the study conducted by the University of Mainz on pain onset levels. Although this research was performed using state-of-the-art testing techniques, the values shown here are the result of a single study in a subject area that has not been the basis of extensive research. There is anticipation that additional studies will be conducted in the future that could result in modification of these values. Testing was conducted using 100 healthy adult test subjects on 29 specific body areas, and for each of the body areas, pressure and force limits for quasi-static contact were established evaluating onset of pain thresholds. The maximum permissible pressure values shown here represent the 75th percentile of the range of recorded values for a specific body area. They are defined as the physical quantity corresponding to when pressures applied to the specific body area create a sensation corresponding to the onset of pain. Peak pressures are based on averages with a resolution size of 1 mm². The study results are based on a test apparatus using a flat (1,4 × 1,4) cm (metal) test surface with 2 mm radius on all four edges. There is a possibility that another test apparatus could yield different results. For more details of the study, see Reference [5].

^b The values for maximum permissible force have been derived from a study carried out by an independent organization (see Reference [6]), referring to 188 sources. These values refer only to the body regions, not to the more specific areas. The maximum permissible force is based on the lowest energy transfer criteria that could result in a minor injury, such as a bruise, equivalent to a severity of 1 on the Abbreviated Injury Scale (AIS) established by the Association for the Advancement of Automotive Medicine. Adherence to the limits will prevent the occurrence of skin or soft tissue penetrations that are accompanied by bloody wounds, fractures or other skeletal damage and to be below AIS 1. They will be replaced in future by values from a research more specific for collaborative robots.

^c The multiplier value for transient contact has been derived based on studies which show that transient limit values can be at least twice as great as quasi-static values for force and pressure. For study details, see References [2], [3], [4] and [7].

^d Critical zone (*italicized*)

Biomechanical Force & Pressure Limits

Appendix L: ISO TS 15066 Test Results, Transient Contact

Quasi-static contact testing with 1, 4, and 8 kg payloads. Forces in green, below, mean that they are within specification.

1 kg										
	Cartesian (XY, Z)				J1			J3		
	acc/dec	100/100	100/100	100/100			25/25			300/300
	dist. (mm)	50	50	50			150			92
	dist. (deg)	-	-	-			15			15
Speed (%)	mm/s	X (N)	Y (N)	Z (N)	deg/s	mm/s	N	deg/s	mm/s	N
10	60	4	12	19	12	115	18	36	220	35
20	120	16	20	37	24	230	35	72	440	68
40	240	31	40	66	48	461	70	144	879	132
60	360	51	62	84	72	691	136	216	1319	185
80	480	67	78	102	96	921	212	288	1758	205
100	600	83	87	123	120	1151	243	360	2198	210
4 kg *										
	Cartesian (XY, Z)				J1			J3		
	acc/dec	100/100	100/100	100/100			25/25			300/300
	dist. (mm)	50	50	50			150			92
	dist. (deg)	-	-	-			15			15
Speed (%)	mm/s	X (N)	Y (N)	Z (N)	deg/s	mm/s	N	deg/s	mm/s	N
10	60	11	4	22	12	115	21	36	220	25
20	120	19	18	34	24	230	41	72	440	77
40	240	39	38	70	48	461	101	144	879	128
60	360	64	65	85	72	691	149	216	1319	175
80	480	82	83	104	96	921	201	288	1758	193
100	600	93	92	123	120	1151	243	360	2198	202
8 kg										
	Cartesian (XY, Z)				J1			J3		
	acc/dec	100/100	100/100	100/100			25/25			300/100
	dist. (mm)	50	50	50			150			92
	dist. (deg)	-	-	-			15			15
Speed (%)	mm/s	X (N)	Y (N)	Z (N)	deg/s	mm/s	N	deg/s	mm/s	N
10	60	6	13	22	12	115	18	36	220	38
20	120	17	21	41	24	230	35	72	440	79
40	240	35	41	71	48	461	70	144	879	140
60	360	55	66	90	72	691	143	216	1319	150
80	480	72	83	110	96	921	212	288	1758	160
100	600	89*	91*	133*	120	1151	257	360	2198	160

ISO TS 15066 Test Results, Transient Contact

Appendix M: ISO TS 15066 Test Results, Quasi-Static Contact

Quasi-static contact testing with 1, 4, and 8 kg payloads. Forces in green in the table below mean that they are within specification.

Examples:

- To keep the robot's Z forces within specification, keep the speed less than or equal to 40%
- For J3 in the 8 kg payload example below, to keep the robot's forces within specification maintain the speed at or below 144 degrees per second or 879 mm per second.

1 kg										
		Cartesian (XY,Z)			J1	J1			J3	
acc/dec		100/10-0	100/10-0	100/50			25/15			300/25
dist.(mm)		35	35	20			15			92
dist.(deg)							1.5			15
Speed (%)	mm/s	X(N)	Y(N)	Z(N)	deg/s	mm/s	J1(N)	deg/s	mm/s	N
10	60	29	76	211	12	115	70*	36	220	69
20	120	36	75	221	24	230	80	72	440	130
40	240	74	103	255	48	461	132	144	879	179
60	360	108	121	285	72	691	130	216	1319	175
80	480	126	132	304	96	921	280	288	1758	175
100	600	140*	144*	319	120	1151	240	360	2198	175

4 kg*										
		Cartesian (XY,Z)			J1	J1			J3	

acc/dec	100/10-0	100/10-0	100/50				25/15			300/25
dist.(mm)	35	35	20				15			92
dist.(deg)							1.5			15

Speed (%)	mm/s	X(N)	Y(N)	Z(N)	deg/s	mm/s	J1(N)	deg/s	mm/s	N
10	60	28	77	206	12	115	73	36	220	103
20	120	46	81	222	24	230	91	72	440	172
40	240	99	120	260	48	461	131	144	879	217
60	360	133	150	290	72	691	154	216	1319	225
80	480	158	174	313	96	921	250	288	1758	224
100	600	182	176	328	120	1151	250	360	2198	224

8 kg										
	Cartesian (X,Y)						J1			J3
acc/dec	100/10-0	100/10-0	100/50				25/15			300/25
dist.(mm)			20				15			92
dist.(deg)							1.5			15

Speed (%)	mm/s	X(N)	Y(N)	Z(N)	deg/s	mm/s	J1(N)	deg/s	mm/s	N
10	60	28	77	209	12	115	66	36	220	113
20	120	60	84	223	24	230	95	72	440	200
40	240	122	140	266	48	461	225	144	879	280
60	360	175	168	301	72	691	280	216	1319	305
80	480	207	193	328	96	921		288	1758	305
100	600	214	203	341	120			360		310

Appendix N: Comparison of Plastic and Foam Covers

Impact Force

Brooks updated the PreciseFlex Direct Drive covers from foam to plastic and conducted comparison impact tests. Here are the test results, which will help users design applications to avoid collisions against a rigid surface that might injure a person.

NOTE: Collisions in free space are not a problem as an operator's hand or forearm can bounce off the covers and the forces are within limits up to 100% speeds.

If the robot satisfies the conditions indicated in the green cells of the "J1 Comparison Table, Measured Force, 1 kg Payload" and "J3 Comparison Table, Measured Force, 1 kg Payload" tables below, it is setup is within the force limits defined by [ISO/TS 15066](#).

- Test results vary for different points of contact. The point of contact in these tests is close to the edge of the plastic cover. Higher forces were recorded when the impact was closer to the edge of the cover where the plastic is more rigid and there is less deflection
- 1 kg payload (contact force in N).
- Impact distance 1.5 deg. (approximately 15 mm @ 550 mm) (J3 @90 deg)

J1 Comparison Table, Measured Force, 1 kg Payload

Speed (%)	Speed (deg/s)	Speed (mm/s)	Deceleration					
			15		20		25	
			Foam covers	Plastic covers (edge)	Foam covers	Plastic covers (edge)	Foam covers	Plastic covers (edge)
10%	12	115	70	82	70	92	77	96
20%	24	230	80	105	83	112	92	129
30%	36	345	95	121	113	136	135	151
40%	48	461	132	144	140	158	140	168
50%	60	576	150	149	260	177	240	183
60%	72	691	130	160	159	186	200	192
70%	84	806	150	165	300	218	310	225

80%	96	921	280	185	300	241	300	240
90%	108	1036	280	205	300	250	305	255
100%	120	1151	240	231*	305	263	305	264

J3 Comparison Table, Measured Force, 1 kg Payload

			Foam covers	Plastic covers (edge)
Payload			1kg	1kg
Acc/dec (%)			300/25	300/25
Distance (deg)			15	15
Distance (mm)			92	92
Par. 2707			0	0
Speed (%)	Speed (deg/s)	Speed (mm/s)	Impact force (N)	Impact force (N)
10	36	220	69	76
20	72	440	130	115
30	108	659	167	135
40	144	879	179	149
50	180	1099	175	165
60	216	1319	175	181
70	252	1539	175	193
80	288	1758	175	202
90	324	1978	175	213
100	360	2198	175	234*

Arm Dimensions

Most robot dimensions do not change. The outer link plastic covers are taller than the foam covers so the mounting screw bosses could be integrated into the halves of the covers, and the plastic covers can be retrofitted to robots with foam covers with the use of custom adapters. This helps the user update to plastic covers, which will not require a return to factory service. Email support@preciseflex@brooksautomation.com for more details.

On robots with plastic covers, the ISO flange has shifted 11 mm lower to extend below the bottom of the thicker plastic cover. The robots also have an internal pulley in a lower position to facilitate the ISO flange position. See the graphics and table below.

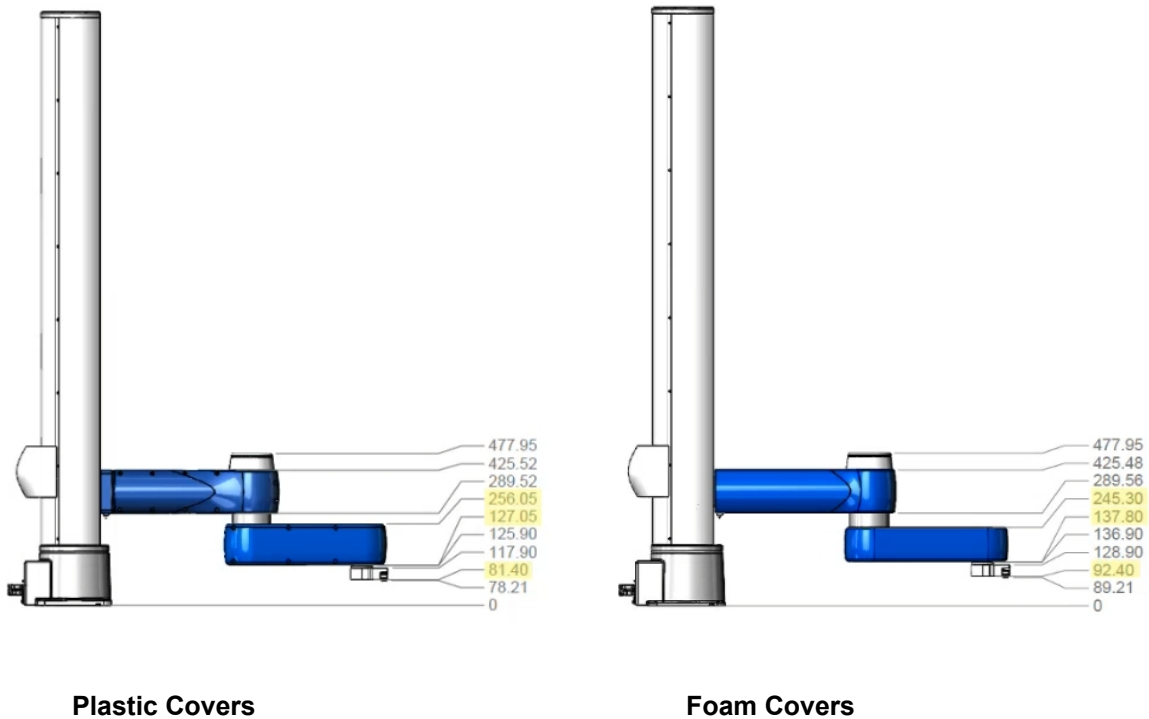

Arm Dimensions

Dimensioned Part	Plastic Covers Version	Foam Covers Version
Bottom of Base Plate	0	0
Bottom of Finger Mounts	78.21	89.21

Dimensioned Part	Plastic Covers Version	Foam Covers Version
Bottom of Gripper Frame	81.40	92.40
Top of Gripper Frame/Bottom of 23 N Gripper Adapter Flange	117.90	128.90
Bottom of ISO Flange with Pulley	125.90	136.90
Bottom of Outer Link Cover	127.05	137.80
Top of Outer Link Cover	256.05	245.30
Bottom of Inner Link Cover	289.52	289.56
Top of Inner Link Cover	425.52	425.48
Top of LED Tower	477.95	477.95

Appendix O: Torque Values for Screws

Use these torque values for all screws and fasteners unless otherwise stated.

Torque Values in Newton-Meters

Screw Size M	Zinc	SS	Zinc	SS	Zinc	SS
	SHCS	SHCS	BHCS	BHCS	FHCS	FHCS
1.6	0.18	0.15	0.00	0.00	0.00	0.00
2	0.37	0.31	0.00	0.00	0.00	0.00
2.5	0.77	0.64	0.00	0.00	0.00	0.00
3	1.34	1.12	0.56	0.51	0.83	0.75
4	3.16	2.63	1.31	1.17	1.53	1.38
5	6.48	5.40	2.66	2.39	3.11	2.79
6	10.96	9.14	4.50	4.05	5.40	4.86