



PreciseFlex™ c10



PreciseFlex™ c8A

PreciseFlex™
c10 and c8A Collaborative Robots
Service Manual

Part Number 629016, Revision B

Brooks Automation

Information provided within this document is subject to change without notice, and although believed to be accurate, Brooks Automation assumes no responsibility for any errors, omissions, or inaccuracies.

AcuLigner™, Advan Tag, AutoTeach™, ATR™, AXM™, BiSymmetrik™, CenterSmart™, Crate to Operate™, CrossingConnect™, DARTS™, Enerta™, e-RMA™, e-Spares™, e-Volution™, Falcon™, FIXLOAD™, FrogLeg™, GuardianPro™, Independent Twin Linear Exchange™, InCooler™, InLigner™, Isoport™, ITLX™, Jet™, Jet Engine™, LEAP™, LeapFrog™, LowProfile™, LPT™, M2 Nano™, Marathon 2, Marathon Express, PASIV™, Pathway™, PowerPak™, PowerTools™, PuroMaxx™, QuadraFly™, Radius™, Radiant™, Radiant Express™, Reliance™, Reliance ATR™, RetroEase™, SCARA™, SmartPM™, SMIF-INX™, SMIF-LPT™, SPOTLevel™, The New Pathway to Productivity™, Time Optimized Trajectory™, Time Optimal Trajectory™, Time Optimized Path™, TopCooler™, TopLigner™, VacuTran™, VersaPort™, WaferEngine™, LEAP™, Pathway™, GIO, GSB, Guidance 6600, Guidance 6430, Guidance 6420, Guidance 6410, Guidance 6000, Guidance 3400, Guidance 3300, Guidance 3200, Guidance 2600, Guidance 2400, Guidance 2300, Guidance 2200, Guidance 1400, Guidance 1300, Guidance 1200, Guidance 0200 Slave Amplifier, Guidance 0006, Guidance 0004, Guidance Controller, Guidance Development Environment, GDE, Guidance Development Suite, GDS, Guidance Dispense, Guidance Input and Output Module, Guidance Programming Language, GPL, Guidance Slave Board, Guidance System, Guidance System D4/D6, IntelliGuide, PreciseFlex™ 100, PreciseFlex™ 300, PreciseFlex™ 400, PreciseFlex™ 3400, PreciseFlex™ c3, PreciseFlex™ c5, PreciseFlex™ c8a™, PreciseFlex™ c10™, PreciseFlex™ 1300, PreciseFlex™ 1400, PreciseFlex™ DD4, PreciseFlex™ DD6, PreciseFlex™ DDR, PreciseFlex™ G5400, PreciseFlex™ G5600, PreciseFlex™ G6400, PreciseFlex™ G6410, PreciseFlex™ G6420, PreciseFlex™ G6430, PreciseFlex™ G6600, PreciseFlex™ GSB Slave Amp, PreciseFlex™ PFD0, PrecisePlace 100, PrecisePlace 0120, PrecisePlace 0130, PrecisePlace 0140, PrecisePlace 1300, PrecisePlace 1400, PrecisePlace 2300, PrecisePlace 2400, PrecisePower 300, PrecisePower 500, PrecisePower 1000, PrecisePower 2000, PreciseVision, IntelliGuide Vision, and RIO logos are trademarks of Brooks Automation.

Fusion®, Guardian®, MagnaTran®, Marathon®, Razor®, Spartan®, Vision®, Zaris®, and the Brooks and design logo are registered U.S. trademarks of Brooks Automation.

All other trademarks are properties of their respective owners.

© 2025 Brooks Automation. All rights reserved. The information included in this manual is proprietary information of Brooks Automation, and is provided for the use of Brooks customers only and cannot be used for distribution, reproduction, or sale without the express written permission of Brooks Automation.

This technology is subject to United States export Administration Regulations and authorized to the destination only; diversion contrary to U.S. law is prohibited.

<p>Brooks Automation 15 Elizabeth Drive Chelmsford, MA 01824-2400 Tel: +1 978-262-2400 Fax: +1 978-262-2500</p>	<p>Brooks Automation, PreciseFlex Collaborative Robots 201 Lindbergh Avenue Livermore, CA 94551 Tel: +1-408-224-2838</p>
---	---



Worldwide Headquarters

15 Elizabeth Drive
Chelmsford, MA 01824 U.S.A.

**Brooks Automation,
PreciseFlex Collaborative Robots**

201 Lindbergh Avenue
Livermore, CA 94551 U.S.A

Technical Support

Location	Contact	Website
North America	+1-800-447-5007 (Toll-Free) +1-978-262-2900 (Local) +1-408-224-2838 (PreciseFlex)	http://www.brooks.com/
Europe	support_preciseflex@brooksautomation.com	
Japan	+81 120-255-390 (Toll Free) +81 45-330-9005 (Local)	
China	+86 21-5131-7066	
Taiwan	+886 080-003-5556 (Toll Free) +886 3-5525258 (Local)	
Korea	1800-5116 (Toll Free)	
Singapore	+65 1-800-4-276657 (Toll Free) +65 6309 0701 (Local)	

General Emails

Division	Email Address
Sales	sales_preciseflex@brooksautomation.com
Technical Support	support_preciseflex@brooksautomation.com
Technical Publications	Technical.Publications@brooksautomation.com



Brooks Automation
15 Elizabeth Drive
Chelmsford, MA
01824-2400
Tel: +1 978-262-2400
Fax: +1 978-262-2500
www.brooks.com

Brooks Locations Worldwide:

Brooks Automation
46702 Bayside Parkway
Fremont, CA 94538
Tel: +1-510-661-5000
Fax: +1-510-661-5166

Brooks Automation
AIM Servicios Administrativos
S de RL de CV
Carretera Huinalá km 2.8
Parque Industrial Las Américas
66640 Apodaca, NL Mexico
Tel: +52 81 8863-6363

**Brooks Automation
(Germany) GmbH**
Ernst-Ruska-Ring 11
07745 Jena, Germany
Tel: +49 3641 4821 100
Fax: +49 3641 4821 4100

**Brooks Automation
(Germany) GmbH**
Daimler-Straße 7
78256 Steißlingen, Germany
Tel: +49-7732-9409-0
Fax: +49-7732-9409-200

Brooks Automation
9601 Dessau Road, Suite 301
Austin, TX 78754
Tel: +1 512-912-2840
Toll-Free: +1 800-367-4887

**Brooks Automation
(Israel) Ltd.**
Mevo Yerach 5
Kiryat-Gat 82000
Israel
Tel: +972 8672 2988
Fax: +972 8672 2966

**Brooks Technology (Shanghai)
Limited**
2nd Floor, No. 72,
887 Zuchongzhi Road
Zhangjiang Hi-Tech
Park Pudong, Shanghai
China 201203
Tel: +86-21-5131-7070
Fax: +86-21-5131-7068

Brooks Japan K.K.
HEADQUARTERS
Nisso Bldg, No 16, 9F
3-8-8 ShinYokohama, Kohoku-ku
Yokohama, Kanagawa 222-0033
Tel: +81-45-477-5570
Fax: +81-45-477-5571

Brooks Japan K.K.
YOKOHAMA TECHNICAL
CENTER
852-1 Kawamuko-cho, Tsuzuki-ku
Yokohama, Kanagawa 224-0044
Tel: +81-45-477-5250
Fax: +81-45-470-6800

Brooks Japan K.K.
KUMAMOTO SERVICE OFFICE
202 Mirai Office II
312-1 Tatsudamachi Yuge
Tatsuda, Kumamoto 861-8002
Tel: +81-96-327-9720
Fax: +81-96-327-9721

Brooks CCS Japan K.K.
CONTAMINATION CONTROL
SOLUTIONS
Nisso Bldg, No 16, 9F
3-8-8 ShinYokohama, Kohoku-ku
Yokohama, Kanagawa 222-0033
Tel: +81-45-477-5570
Fax: +81-45-477-5571

Brooks Automation Ltd.
TAIWANHEADQUARTERS
5F-5, No.32, Tai-Yuen Street
Chu-Pei City
Hsinchu County 302, Taiwan,
R.O.C.
Tel: +886-3-552 5258
Fax (G&A): +886-3-552 5255
Fax (Sales): +886-3-552 5200

Brooks Automation Korea, Inc.
#35 Giheungdanji-Ro 121Beon-
Gil
Giheung-Gu, Yongin-Si
Gyeonggi-Do, 17086
Korea
Tel: +82-31-288-2500
Fax: +82-31-287-2111

**Brooks Automation CCS RS
AG**
Lohstampfstrasse 11
CH-8274 Tagerwilen, Switzerland
Tel: + 41 71-666-72-10
Fax: + 41 71-666-72-11

Brooks Automation Korea
#35 Giheungdanji-Ro 121Beon-
Gil
Giheung-Gu, Yongin-Si
Gyeonggi-Do, 17086
Korea
Tel: +82-31-288-2500
Fax: +82-31-287-2111

Brooks Automation (S) Pte Ltd
51-18-C1 Menara BHL,
57 Jalan Ahmad Shah,
10050, Penang,
Malaysia
Tel: +60 4 3701012
Fax: +60 4 3701015

**Brooks Automation
(Singapore) Pte Ltd**
Blk 5008 Ang Mo Kio Avenue 5
#05-08, Techplace II
Singapore 569874
Tel: +65-6836-3168
Fax: +65-6836-3177

Brooks Automation Ltd.
TAINAN OFFICE
3F., No.11, Nanke 3rd Rd., Xinshi
Dist.
Tainan Science Park
Tainan City 74147, Taiwan
(R.O.C.)
TEL: +886-6-505-0268
FAX: +886-6-505-5228

**Brooks Automation
Precise Collaborative Robotics**
201 Lindbergh Drive
Livermore, CA 94551
Tel: +1-978-262-2400

c10/c8A Service Manual Revision History

Revision	ECO	Date	Action	Author
A	Agile release skipped	March 31, 2024	Released manual at Rev. A to follow standard Brooks technical publication styles.	M. Ashenfelder
B	EC154168	June 7, 2024	Released manual at Rev. B to follow standard Brooks technical publication styles	M.Ashenfelder

Table of Contents



1. Safety	1
Safety Setup	1
Explanation of Hazards and Alerts	1
Safety Text	1
Safety Icons	2
Signal Words and Colors	2
Alert Example	3
General Safety Considerations	4
Electrical Hazards	6
Ergonomic Hazards	8
Emergency Stop Circuit (E-Stop)	9
Recycling and Hazardous Materials	9
2. Service Procedures	10
Recommended Tools	10
Troubleshooting	10
Encoder Operation Error	12
Replacing the Encoder Batteries	14
Calibrating the Robot: Setting the Encoder Zero Positions	16
Replacing Belts and Motors	21
Tensioning or Replacing the J2 (Z Column) Belts	21
Tensioning the 1st Stage Belt	21
Tensioning the 2nd Stage Belt	22
Replacing the Z column Stage One Timing Belt	23
Replacing the Z Column Stage Two Timing Belt	24
Recovering from Corrupted PAC Files	26
Replacing the Outer Link Motors or Harmonic Drives in the c8A	27
Replacing the Robot Main Controller	29
Replacing the Z-axis Slave Controller	31
Replacing the J3 Axis Slave Controller	33
Replacing the J4 or Gripper Slave Controller in c10	35
Replacing the Gripper and Slip Ring in the c10	37
Adjusting the Gripper Backlash or Centering Fingers	40
Replacing the Main Harness	41
Replacing the J3 Clock Spring Harness to the J4 Motor	42
Replacing the J4 to Gripper Controller Harness in the c10	44
Replacing the J4 slave controller in the c8A	45
Replacing the J6 Motor Pigtail Harness	46
Appendices	48
Appendix A: c8A Product Specifications	49
Appendix B: c10 Product Specifications	51
Appendix C: Environmental Specifications	53
Appendix D: Spare Parts List	54
Appendix E: Preventative Maintenance	56

Appendix F: Safety Circuits for the c8A and c10 Robots	57
Appendix G: System Diagram and Power Supplies	59
Appendix H: Control System Overview	75
Appendix I: Belt Tensions, Gates Tension Meter	77
Appendix J: Example Performance Level Evaluation	79
Normal Operator Interaction with Robot:	79
Possible Low Frequency (rare) Interaction with Robot:	79
Appendix K: Table A2 from ISO/TS 15066: 2016	80
Biomechanical Force and Pressure Limits	80
Appendix L: c10 - Test Methods for Measuring Forces and Pressures in Human-Robot Contact .	82
Application	82
Contact Hazards and Measuring Points: Contact Hazard 1	82
Contact Hazards and Measuring Points: Contact Hazard 2	87
Appendix M: c8A - Test Methods for Measuring Forces and Pressures in Human-Robot Contact	91
Application	91
Contact Hazards and Measuring Points: Contact Hazard 1	91
Contact Hazards and Measuring Points: Contact Hazard 2	95
Appendix N: Torque Values for Screws	105
Appendix O: Conditions of Acceptability	106

1. Safety

Safety Setup

Brooks uses caution, warning, and danger labels to convey critical information required for the safe and proper operation of the hardware and software. Read and comply with all labels to prevent personal injury and damage to the equipment.

 DANGER Read the Safety Chapter	
<p>Failure to review the <i>Safety</i> chapter and follow the safety warnings can result in serious injury or death.</p> <ul style="list-style-type: none">• All personnel involved with the operation or maintenance of this product must read and understand the information in this safety chapter.• Follow all applicable safety codes of the facility as well as national and international safety codes.• Know the facility safety procedures, safety equipment, and contact information.• Read and understand each procedure before performing it.	

Explanation of Hazards and Alerts

This manual and this product use industry standard hazard alerts to notify the user of personal or equipment safety hazards. Hazard alerts contain safety text, icons, signal words, and colors.

Safety Text



Hazard alert text follows a standard, fixed-order, three-part format.

- Identify the hazard
- State the consequences if the hazard is not avoided

- State how to avoid the hazard.

Safety Icons



- Hazard alerts contain safety icons that graphically identify the hazard.
- The safety icons in this manual conform to [ISO 3864-1:2011](#) *Graphical symbols — Safety colours and safety signs* and [ANSI Z535](#) standards.

Safety Icon Examples	
	Warning
	Two-Person Lift
	Electric Shock

Signal Words and Colors

Signal words and colors inform of the level of hazard.

	<p>Danger indicates a hazardous situation which, if not avoided, will result in serious injury or death.</p> <p>The Danger signal word is white on a red background with an exclamation point inside a yellow triangle with black border.</p>
---	--

	<p>Warning indicates a hazardous situation which, if not avoided, could result in serious injury or death.</p> <p>The Warning signal word is black on an orange background with an exclamation point inside a yellow triangle with black border.</p>
	<p>Caution indicates a hazardous situation or unsafe practice which, if not avoided, may result in minor or moderate personal injury.</p> <p>The Caution signal word is black on a yellow background with an exclamation point inside a yellow triangle with black border.</p>
	<p>Notice indicates a situation or unsafe practice which, if not avoided, may result in equipment damage.</p> <p>The Notice signal word is white on blue background with no icon.</p>

Alert Example

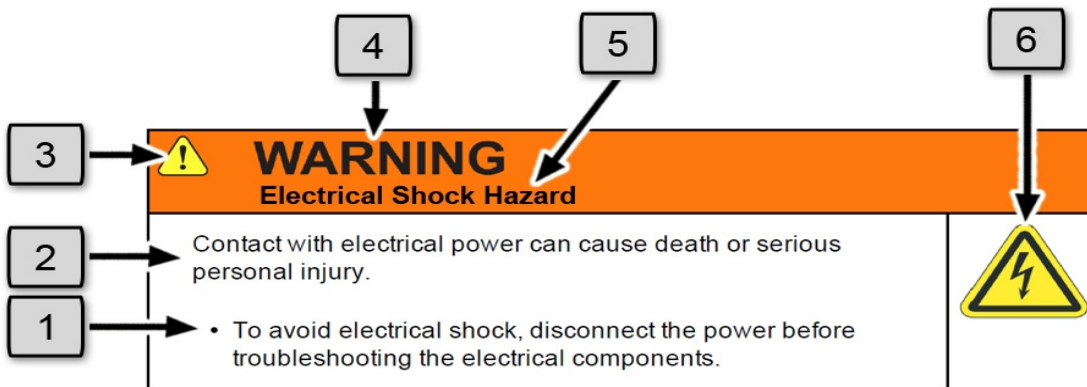

The following is an example of a Warning hazard alert.







Number	Description
1.	How to Avoid the Hazard
2.	Source of Hazard and Severity
3.	General Alert Icon



Number	Description
4.	Signal Word
5.	Type of Hazard
6.	Hazard Symbol(s)



General Safety Considerations



 WARNING Software	
<p>Software is not safety rated. Unplanned motion can occur as long as power is supplied to the motors. Maximum torque could be momentarily applied that may cause equipment damage or personal injury.</p> <ul style="list-style-type: none">• Only operate the robot with its covers installed.• Guarantee that safety controller features are in place (for example, an emergency stop button and protective stop).• Regularly test safety components to prove that they function correctly.	 



 WARNING Robot Mounting	
<p>Before applying power, the robot must be mounted on a rigid test stand, secure surface, or system application. Improperly mounted robots can cause excessive vibration and uncontrolled movement that may cause equipment damage or personal injury.</p> <ul style="list-style-type: none">• Always mount the robot on a secure test stand, surface, or system before applying power.	



 WARNING Do Not Use Unauthorized Parts	
<p>Using parts with different inertial properties with the same robot application can cause the robot's performance to decrease and potentially cause unplanned robot motion that could result in serious personal injury.</p> <ul style="list-style-type: none">• Do not use unauthorized parts.• Confirm that the correct robot application is being used.	

 WARNING Magnetic Field Hazard	
<p>This product contains magnetic motors that can be hazardous to implanted medical devices, such as pacemakers, and cause personal harm, severe injury, or death.</p> <ul style="list-style-type: none">• Maintain a safe working distance of 30 cm from the motor when with an energized robot if you use a cardiac rhythm management device.	

 CAUTION Unauthorized Service	
<p>Personal injury or damage to equipment may result if this product is operated or serviced by untrained or unauthorized personnel.</p> <ul style="list-style-type: none">• Only qualified personnel who have received certified training and have the proper job qualifications are allowed to transport, assemble, operate, or maintain the product.	



 CAUTION Damaged Components	
<p>The use of this product when components or cables appear to be damaged may cause equipment malfunction or personal injury.</p> <ul style="list-style-type: none">• Do not use this product if components or cables appear to be damaged.• Place the product in a location where it will not get damaged.• Route cables and tubing so that they do not become damaged and do not present a personal safety hazard.	



 CAUTION Inappropriate Use	
<p>Use of this product in a manner or for purposes other than for what it is intended may cause equipment damage or personal injury.</p> <ul style="list-style-type: none">• Only use the product for its intended application.• Do not modify this product beyond its original design.• Always operate this product with the covers in place.	



 CAUTION Seismic Restraint	
<p>The use of this product in an earthquake-prone environment may cause equipment damage or personal injury.</p> <ul style="list-style-type: none">• The user is responsible for determining whether the product is used in an earthquake prone environment and installing the appropriate seismic restraints in accordance with local regulations.	

Electrical Hazards

Refer to the specifications of the *Guidance Controller Quick Start Guide* for the electrical power.

 <b style="font-size: 1.2em; margin-left: 10px;">DANGER <b style="font-size: 0.9em; margin-left: 10px;">Electrical Shock Hazard	
<p>Contact with electrical power can cause personal harm and serious injury.</p> <ul style="list-style-type: none"> To avoid electrical shock, disconnect the power before troubleshooting the electrical components. Check the unit's specifications for the actual system power requirements and use appropriate precautions. Never operate this product without its protection covers on. 	

 <b style="font-size: 1.2em; margin-left: 10px;">WARNING <b style="font-size: 0.9em; margin-left: 10px;">Electrical Burn	
<p>Improper electrical connection or connection to an improper electrical supply can result in electrical burns resulting in equipment damage, serious injury, or death.</p> <ul style="list-style-type: none"> Always provide the robot with the proper power supply connectors and ground that are compliant with appropriate electrical codes. 	



 <b style="font-size: 1.2em; margin-left: 10px;">WARNING <b style="font-size: 0.9em; margin-left: 10px;">Electrical Fire Hazard	
<p>All energized electrical equipment poses the risk of fire, which may result in severe injury or death. Fires in wiring, fuse boxes, energized electrical equipment, computers, and other electrical sources require a Class C extinguisher.</p> <ul style="list-style-type: none"> Use a fire extinguisher designed for electrical fires (Class C in the US and Class E in Asia). It is the facility's responsibility to determine if any other fire extinguishers are needed for the system that the robot is in. 	



NOTICE



Improper handling of the power source or connecting devices may cause component damage or equipment fire.

- Connect the system to an appropriate electrical supply.
- Turn off the power before servicing the unit.
- Turn off the power before disconnecting the cables.

Ergonomic Hazards



 CAUTION Heavy Lift Hazard	
<p>Failure to take the proper precautions before moving the robot could result in back injury and muscle strain.</p> <ul style="list-style-type: none">• Use a lifting device and cart rated for the weight of the drive or arm.• Only persons certified in operating the lifting device should be moving the product.	

 CAUTION Tipover Hazard	
<p>This product has a high center of gravity which may cause the product to tip over and cause serious injury.</p> <ul style="list-style-type: none">• Always properly restrain the product when moving it.• Never operate the robot unless it is rigidly mounted.	

 CAUTION Trip Hazard	
<p>Cables for power and communication and facilities create trip hazards which may cause serious injury.</p> <ul style="list-style-type: none"> • Always route the cables where they are not in the way of traffic. 	

Emergency Stop Circuit (E-Stop)

The integrator of the robot must provide an external emergency stop switch.

 WARNING Emergency Stop Circuit	
<p>Using this product without an emergency stop circuit may cause personal injury.</p> <ul style="list-style-type: none"> • Customer is responsible for integrating an emergency stop circuit into their system. • Do not override or bypass the emergency stop circuit. 	

Recycling and Hazardous Materials

Brooks Automation complies with the EU Directive 2002/96/EU Waste Electrical and Electronic Equipment (WEEE).

The end user must responsibly dispose of the product and its components when disposal is required. The initial cost of the equipment does not include the cost of disposal. For further information and assistance in disposal, email Brooks Automation Technical Support at support_preciseflex@brooksautomation.com.

2. Service Procedures

Recommended Tools

The following tools are recommended for these service procedures:

1. Gates Sonic Belt Tension Meter, Model 507C for checking timing belt tension
2. A set of metric “stubby” hex L-keys, for example McMaster Carr PN 6112A21 with 1.5, 2.0, 2.5, 3.0, 4, 5, and 6 mm L Keys
3. A set of metric hex drivers including 1.27, 1.5, 2.0, 2.5 and 3.0 mm driver, for example McMaster Carr PN 52975A21
4. Metric ball end hex drivers, 4.0 mm and 5.0 mm for M5 and M6 SHCS
5. A pair of tweezers or needle nose pliers
6. A pair of side angle cutters
7. Small flat bladed screwdriver, with 1.5 mm wide blade typical

Troubleshooting

PreciseFlex robots and controllers have an extensive list of error messages. Refer to the *PreciseFlex Library* to search for a specific error message and cause. Listed below are a few errors that may be generated by hardware failures.

Hardware Failure Errors

Symptom	Recommended Action
System error message generated	
E-Stop not Enabled	Check 9 pin Dsub for Estop jumpers and Estop Dsub plugged in.
Encoder Battery Low”	Replace absolute encoder battery on back of column or outer link.
Encoder Battery Down	If encoder cable has been disconnected, recalibrate robot. If battery voltage has dropped below 2.5V replace encoder battery and recalibrate robot.
Encoder Operation Error	Joint rotated too quickly with power off. See "Encoder Operation Error."

Symptom	Recommended Action
Encoder Data, Accel/decel Limit Error	Encoder cable may be damaged and encoder is getting intermittent communication, causing apparent jumps in position. Check encoder connectors. Replace motor/encoder or encoder only on DD axes.
Encoder Communication Error	Check encoder connectors. Replace encoder cable or motor/encoder.
Encoder quadrature error	Replace slip ring. Replace motor/encoder (only Gripper motor).
Missing zero index	See "Encoder quadrature error" above.
Motor duty cycle exceeded	Reduce speed or acceleration of robot. Check for instability.
Amplifier under voltage	Motor power supply has reached current limit and shutdown. Slow down the robot. Check the Energy Dump PCA. Replace the 48V supply.
Amplifier Fault	Check harness and motor for shorts.
Amplifier Over Voltage	Check energy dump resistor is connected. Check harness for shorts.
Soft Envelope Error	Make sure robot not pressing against surface. If this occurs on the gripper repeatedly, replace slip ring.
Hard Envelope Error	Typically means robot has crashed into something.
Pneumatic Gripper Sensor not working	Check continuity of cable through wrist. Check green lights on sensor to see if sensor is triggering.
Time Out Nulling Error	Check that joint is free to move with brake off. Check that joint is not vibrating or unstable. If unstable check belt tension. If Gripper, check for free motion, if OK replace slip ring.
Joint Out of Range	The joint actual or commanded position may be beyond the software limit stop. Move joint back into range while monitoring virtual pendant or check program for commanded position.
PAC Files Corrupted	See "Recovering from Corrupted PAC Files."
Physical or audible problem	
Brown streaks on linear bearing	Clean with alcohol and add grease to bearing blocks. This should not be required sooner than 20,000 hours of run time. Grease is Alvania Grease EP2 from Shell.
Mechanical noise from any joint	Check joint bearings for failure. Re-tension the belt.
Loud buzzing or vibration from any joint	Re-tension the timing belts. If the timing belt will not hold tension, replace it.
Squeaking from Z belt	Apply thick grease to front and rear edges of belt, (Mobile 222 XP). Belt can get stiff over time and squeak against pulley flanges.

Encoder Operation Error

The c8A and c10 robots are equipped with absolute encoders that keep track of the robot position even when AC power to the robot is disconnected. **There are batteries in the back of the Z column of the robot and outer link that provides standby power to the encoders for the Z axis and outer link motors. J1, J3, and J4 on the c10 axes have single turn absolute encoders and do not require standby batteries.** However, if a 60 N servo gripper is installed on the c10, the GSB4 associated with this gripper will be mounted in the outer link and will need a battery installed. In standby mode, there is a limit on how quickly the motor can turn and still have the standby counter operate properly. The limits are 6,000 rpm and 4000 rad/s². Even at 100% speeds the robot joints normally do not move faster than about 2,000 rpm and 1300 rad/s². However, if the robot is shocked during shipping, it is possible the standby operation acceleration error limit may be exceeded. This can generate an encoder operation error that will prevent the robot from homing after power up.

This error will be displayed in the Operator Window of the Web Interface as “Encoder Operation Error” Robot 1: <axis number>.

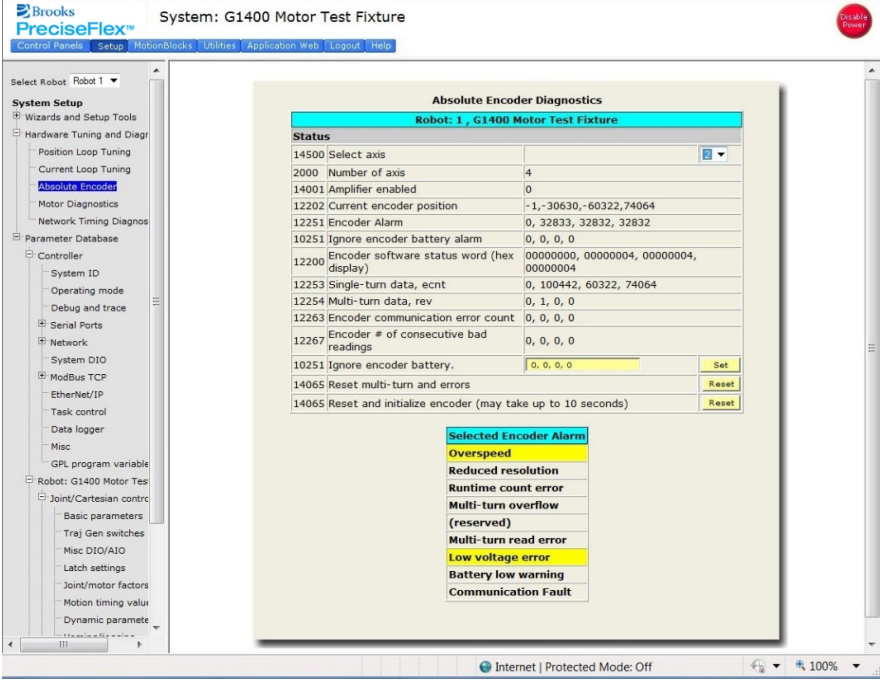

Assuming the robot has not been damaged by the shipping process, reset this error by performing the following procedure.

Step	Action
1.	Access the Web Operator Interface to the robot with either “Maintenance” or “Administrator” privileges.

Step	Action
2.	<p>In the “Setup” menu, select “Hardware Tuning and Diagnostics”, then select “Absolute Encoder”. A screen similar to that shown below should display.</p> 
3.	<p>In the drop-down menu at the top right of the screen, select the robot axis that was associated with the error and check to see if the Overspeed panel is yellow. This indicates an overspeed error during encoder standby mode due to shock or vibration. This error can be reset by selecting the reset button next to “Reset and initialize encoder.” This button resets error flags, but does NOT reset the encoder counters. The robot can then be homed normally.</p>
4.	<p>For cases where the encoder operation error was triggered by shipping vibration, IN MOST CASES the encoder will not have lost any position data. However, after homing the robot it is a good idea to move the robot to the calibration position (using the calibration pins if desired-see Calibrating the Robot), or another known position, and check the joint angles in the Virtual Pendant in the Web Operator Interface. See the Calibration Procedure in Calibrating the Robot: Setting the Encoder Zero Positions for the joint angles in the Calibration Position.</p>

If the robot joints after this procedure followed by homing are different from the above, then the robot needs to be re-calibrated. See the procedure in [Calibrating the Robot: Setting the Encoder Zero Positions](#).

Replacing the Encoder Batteries

 DANGER Electrical Shock	
<p>Before replacing the encoder battery, the AC power should be disconnected. Removing the front cover allows access to the AC power terminals.</p>	

The Encoder Batteries are designed to last for several years with robot power off. With robot power on, there is no drain on the battery. The battery voltage is monitored by the system. The nominal battery voltage is 3.6 Volts. If the battery voltage drops to 3.3 Volts an error message “Encoder Battery Low” is generated. At this level the absolute encoder backup function will still work, however the Battery should be replaced. If the voltage drops to 2.5 Volts, an error message “Absolute Encoder Down” is generated. At this point, the absolute encoder backup function will not work.

Note that if any motor/encoder is disconnected from the encoder battery by disconnecting the encoder cable, the “Encoder Battery Low” or Encoder Battery Down” message will be generated. However, in this case the encoder battery does not need to be replaced. It is only necessary to re-calibrate the robot (see [Calibrating the Robot: Setting the Encoder Zero Positions](#)). See the battery locations below.

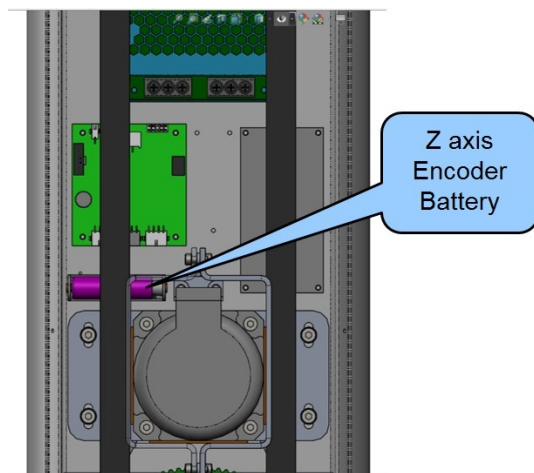

Location of the Z Axis Encoder Battery

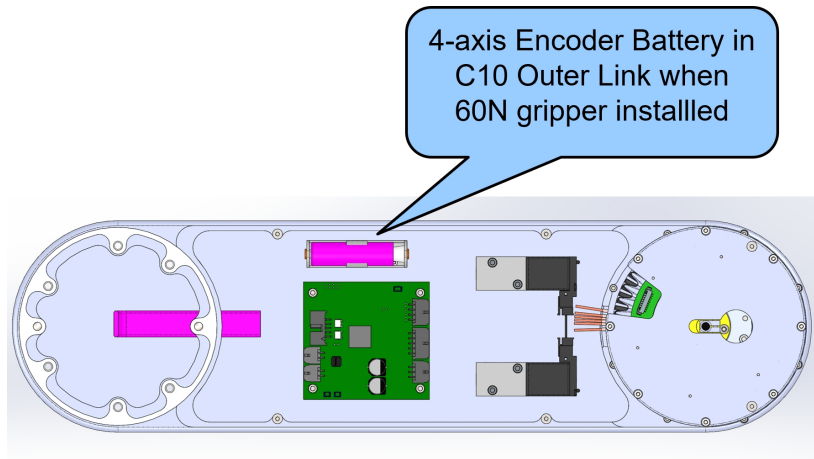

Location of the Four-Axis Encoder Batteries

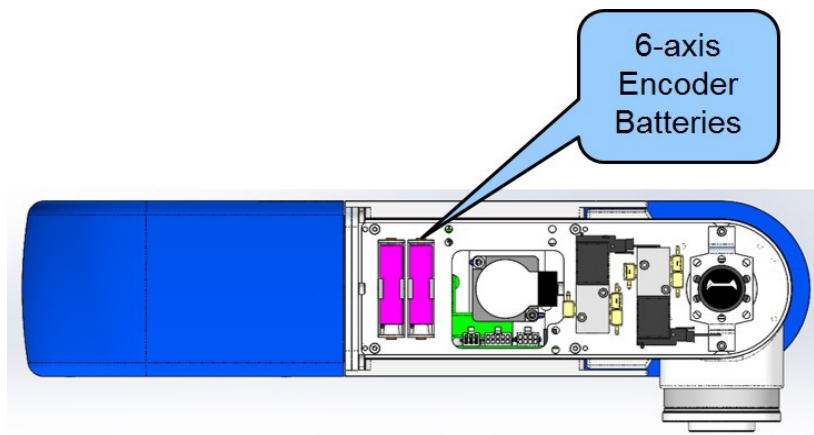

Location of the Six-Axis Encoder Batteries

Tools Required

- 2.0mm hex driver or hex L wrench

Parts Required

- New Encoder Battery PN G1S0-EC-X0007

To replace the Encoder Battery for the Z axis, perform the following procedure.

Step	Action
1.	Turn off power to the robot and remove the AC power plug.
2.	Remove the curved back cover from the Z column.
3.	Replace the battery.

Step	Action
4.	Replace the curved back cover on the Z column.

To replace the Encoder Battery in the four-axis outer link, perform the following procedure.

Step	Action
1.	Remove the outer link cover from the sides of the outer link.
2.	Remove the outer link top sheet metal cover.
3.	Replace the battery.
4.	Replace the covers.

To replace the Encoder Battery in the 6-axis outer link, perform the following procedure.

Step	Action
1.	Remove the outer link covers.
2.	Replace the two batteries.
3.	Replace the cover.

If the “Encoder Battery Down” error is generated, the robot must be re-calibrated after this procedure. See [Calibrating the Robot: Setting the Encoder Zero Positions](#). Otherwise, it is not necessary to re-calibrate the robot.

Calibrating the Robot: Setting the Encoder Zero Positions

Cal_PP is a service program that must be run to set the zero positions of the absolute encoders on each motor. The zero positions must be re-established if any of the motors are replaced, their cables disconnected for a long duration, or the encoder backup battery has been disconnected. Cal_PP is supplied on the flash drive of the robot and is available in the Support area of the Brooks website. To run Cal_PP, the controller must be configured to run GPL programs and Cal_PP must be loaded into the controller's memory (See [Preventative Maintenance](#)).

Tools Required

- Calibration Kit with M6 X 40 mm dowel
- (2) M5 X 45 mm Socket Head Cap Screws
- (2) M5 jam nuts

To define the zero positions of the c8A and c10 robot axes using Cal_PP, perform the following procedure.

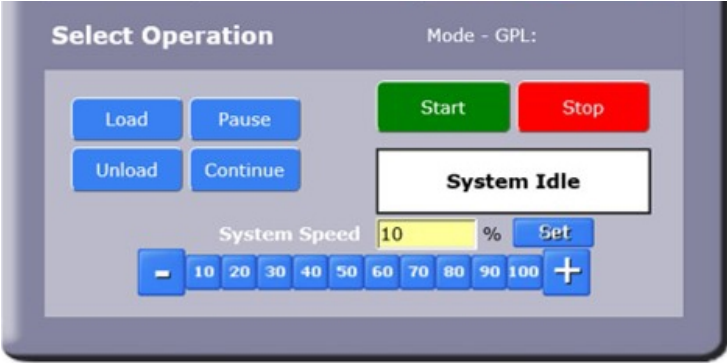
Step	Action
1.	Enable power to the robot's controller, but do not turn on power to the motors. (This procedure should be executed with motor power off. The robot does not move.)
2.	<p>The CALPP program is typically installed at the factory and should be loaded into flash memory. Using the web-based Operator Control Panel, click UnLoad to unload any currently loaded programs. This ensures that no GPL project is currently selected for execution.</p> 
3.	Click Load . This displays a list of projects that are in the flash disk and available for execution.
4.	In the window, click CALPP_RevXX .
5.	When ready to execute the project, click Start .
6.	If CALPP is not loaded in the robot, first Load Cal_PP into the controller's memory from a PC, using the web Operator Control Panel.
7.	Manually move the robot into the configuration shown below.
8.	Ensure the Z-axis is resting on the lower hard stop by releasing the Z-axis brake by pushing on the brake release button under the inner link while supporting the robot arm with your hand and lowering the robot arm gently until it rests on the lower hard stop.
9.	Install an M6 X 40 mm Calibration Pin in the base platter.

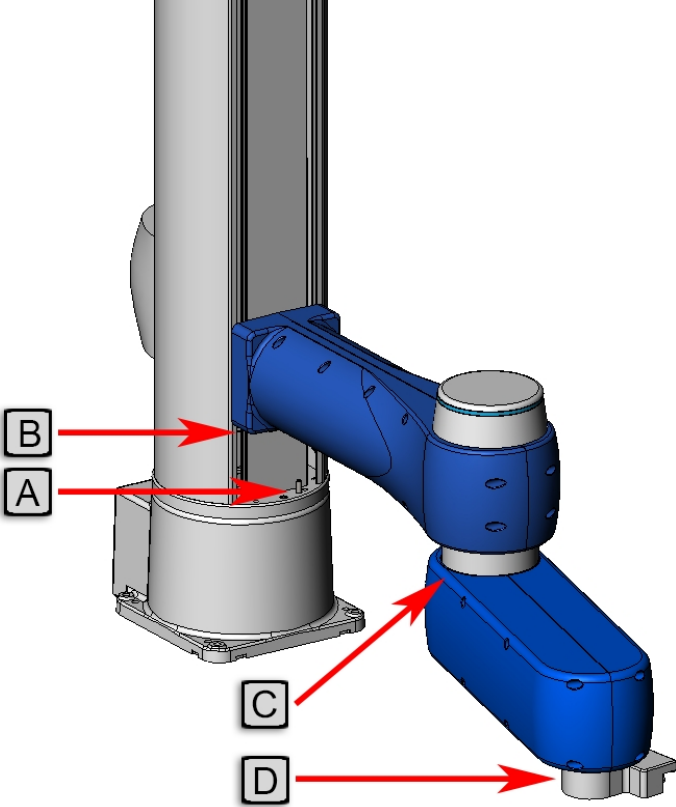
Step	Action										
10.	Rotate J3 counter-clockwise, when viewed looking down, until its hard stop.										
11.	Start CAL_PP_XX .										
12.	For the c10, rotate J4 counter-clockwise, when viewed looking down, until its hard stop.										
13.	 <p data-bbox="310 1283 565 1314">CALPP Position c10</p> <table border="1" data-bbox="310 1314 1365 1640"> <thead> <tr> <th data-bbox="310 1314 488 1377">Letter</th> <th data-bbox="488 1314 1365 1377">Description</th> </tr> </thead> <tbody> <tr> <td data-bbox="310 1377 488 1444">A</td> <td data-bbox="488 1377 1365 1444">Insert M6 X 40 pin here to center J1 (0 degrees).</td> </tr> <tr> <td data-bbox="310 1444 488 1512">B</td> <td data-bbox="488 1444 1365 1512">Lower Z to hard stop (-2mm).</td> </tr> <tr> <td data-bbox="310 1512 488 1579">C</td> <td data-bbox="488 1512 1365 1579">Rotate J3 CCW to hard stop (350 degrees).</td> </tr> <tr> <td data-bbox="310 1579 488 1646">D</td> <td data-bbox="488 1579 1365 1646">Rotate Gripper CCW to hard stop (300 degrees).</td> </tr> </tbody> </table>	Letter	Description	A	Insert M6 X 40 pin here to center J1 (0 degrees).	B	Lower Z to hard stop (-2mm).	C	Rotate J3 CCW to hard stop (350 degrees).	D	Rotate Gripper CCW to hard stop (300 degrees).
Letter	Description										
A	Insert M6 X 40 pin here to center J1 (0 degrees).										
B	Lower Z to hard stop (-2mm).										
C	Rotate J3 CCW to hard stop (350 degrees).										
D	Rotate Gripper CCW to hard stop (300 degrees).										

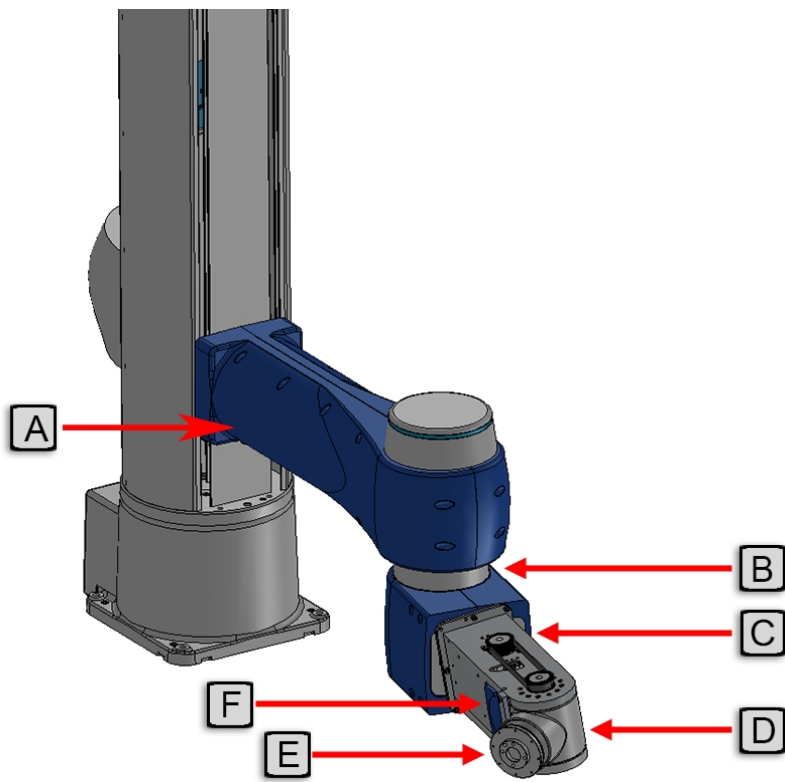
Step	Action														
14.	 <p>The diagram shows a blue robot arm with a grey base. Red arrows point from callout boxes A through F to specific locations on the robot: A points to the base of the vertical column; B points to the upper wrist joint; C points to the lower wrist joint; D points to the end effector; E points to the wrist joint; and F points to the end effector.</p> <p>CALPP Position c8A</p> <table border="1" style="width: 100%; border-collapse: collapse;"> <thead> <tr style="background-color: #0056b3; color: white;"> <th>Letter</th> <th>Description</th> </tr> </thead> <tbody> <tr> <td>A</td> <td>Lower Z axis to hard stop (-2mm).</td> </tr> <tr> <td>B</td> <td>Rotate J3 CCW to hard stop (350 degrees).</td> </tr> <tr> <td>C</td> <td>Rotate J4 CCW to hard stop.</td> </tr> <tr> <td>D</td> <td>Rotate J5 to press against calibration bar.</td> </tr> <tr> <td>E</td> <td>Rotate J6 CCW to hard stop.</td> </tr> <tr> <td>F</td> <td>Install J5 calibration bar with 2 M3 x 12 SHCS.</td> </tr> </tbody> </table>	Letter	Description	A	Lower Z axis to hard stop (-2mm).	B	Rotate J3 CCW to hard stop (350 degrees).	C	Rotate J4 CCW to hard stop.	D	Rotate J5 to press against calibration bar.	E	Rotate J6 CCW to hard stop.	F	Install J5 calibration bar with 2 M3 x 12 SHCS.
Letter	Description														
A	Lower Z axis to hard stop (-2mm).														
B	Rotate J3 CCW to hard stop (350 degrees).														
C	Rotate J4 CCW to hard stop.														
D	Rotate J5 to press against calibration bar.														
E	Rotate J6 CCW to hard stop.														
F	Install J5 calibration bar with 2 M3 x 12 SHCS.														

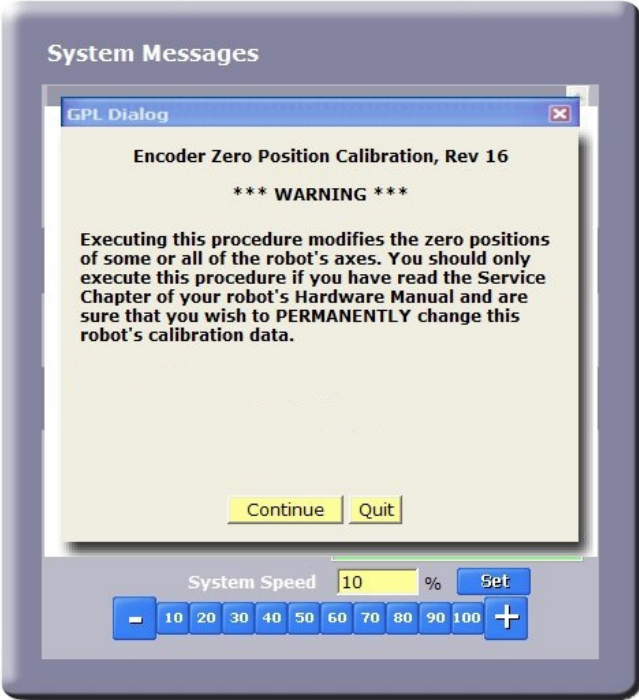
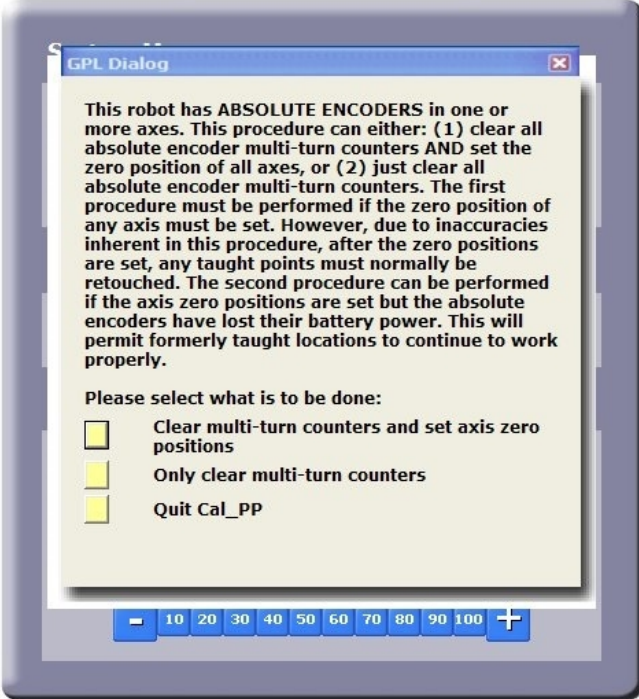
Step	Action
15.	<p>With the CALPP application loaded, click Start. An application should start and prompt the user to confirm the correct robot position for calibration.</p> 
16.	



Step	Action
17.	A dialogue box will display that allows the J4 and J5 brake to be released for the c8A to allow it to be positioned correctly for CALPP. After the robot is correctly positioned, execute CALPP. The CALPP application takes about one minute to run.
18.	After calibration is complete, use the brake release button and move the Z-axis a few millimeters away from the hard stop. Failing to do this will produce an error as the robot is outside of the soft stop limits.
19.	Ensure that the pin is removed from the base rotation plate and the calibration bar from the outer link of the c8A.
20.	Enable power and home the robot. Calibration does not take effect until the robot is homed.

Replacing Belts and Motors

The timing belts and harmonic drives may need service after 20,000 hours, depending on the payload and duty cycle. The motors are designed to last the life of the robot. It is not expected that they will need to be replaced in the field. In most cases, if a belt or a motor needs to be replaced, the robot should be returned to the factory. While there are procedures in this manual for replacing belts and motors, only experienced service technicians should attempt these procedures.

Tensioning or Replacing the J2 (Z Column) Belts

Tensioning the 1st Stage Belt

 DANGER Electrical Shock	
Before tensioning the timing belts or replacing any motors, the AC power should be disconnected. Removing the rear cover allows access to the AC power terminals.	



Tools Required

- Gates Sonic Belt Tension Meter, Model 508 C
- 2.0 mm hex driver or hex L wrench
- 4.0 mm hex ball end driver

To tension the 1st stage belt, perform the following procedure.

Step	Action
1.	Turn off robot power and remove the AC power cord.
2.	Remove the curved rear cover of the robot.
3.	Loosen the (4) M5 locking screws on the J1 Motor Mount Bracket to allow the Mount Bracket to slide up and down.
4.	Measure the tension with the belt tension meter as described in Belt Tensions, Gates Tension Meter .
5.	Adjust the M5 tension screw.
6.	After adjusting the tension screw, tighten the M5 locking screws to lock the assembly in place. Replace the rear cover.

Tensioning the 2nd Stage Belt

 DANGER Electrical Shock	
<p>Before tensioning the timing belts or replacing any motors, the AC power should be disconnected. Removing the rear cover allows access to the AC power terminals.</p>	

Tools Required

- Gates Sonic Belt Tension Meter, Model 508C
- 2.0 mm hex driver or hex L wrench
- 3.0 mm hex driver
- 4.0 mm ball end hex

To tension the 2nd stage J1 belt, perform the following procedure.

Step	Action
1.	Turn off the robot power and remove the AC power cord.
2.	Remove the curved rear cover of from the Z column.

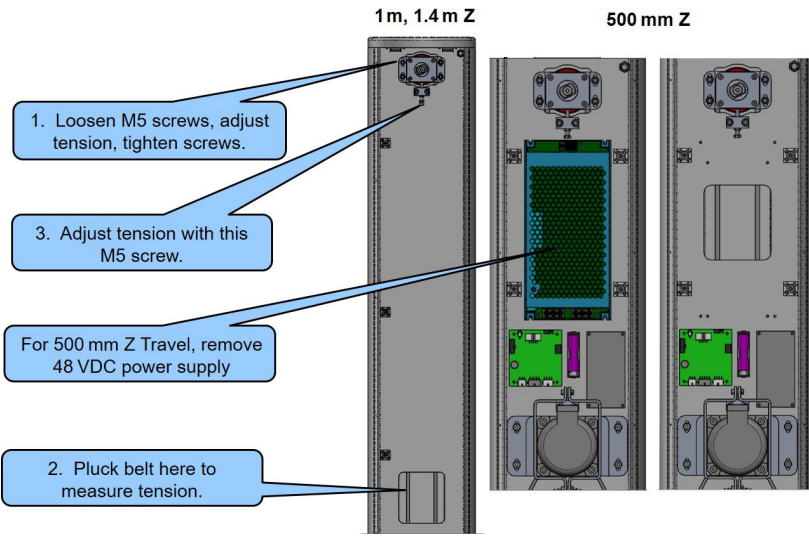
Step	Action
<p>3.</p>	<p>Loosen the (4) M5 locking screws on the Z idler block.</p> 
<p>4.</p>	<p>For the 1.42 m and 1.0 m Z travel robots, the tension screw and belt tension access hole can be accessed at this point. For the 500 mm Z travel robot it is necessary to remove the 48VDC power supply in order to access the belt tension access hole and the tension screw. As an alternative, the top cover and front cover may be removed to access the stage 2 timing belt from the front of the robot. This is the easier method if tape seals are not installed.</p>
<p>5.</p>	<p>Adjust the second stage Z belt tension per Belt Tensions, Gates Tension Meter, tighten clamping screws, and replace parts. It may be helpful to move the carriage upwards on the taller robots so that the distance from the top idler pulley to belt attachment on the Z carriage is 500 mm, in order to get a higher frequency on the belt, which can be easier to measure with the tension meter. Use the 500 mm span in this case.</p>

Replacing the Z column Stage One Timing Belt



DANGER
Electrical Shock

Before replacing the power supplies, the AC power should be removed.



Tools Required

- 2.0 mm hex driver
- 4.0 mm ball end hex driver
- 2.5 mm hex driver or hex L wrench



Spare Parts Required

- J2 Stage One Belt, PN PFD0-MC-X0006.

To replace the Z column stage one timing belt, perform the following procedure.

Step	Action
1.	Turn off the robot power and remove the AC power cord.
2.	Remove the curved rear cover from the Z column.
3.	Loosen the M5 Z motor bracket clamping screws and release the tension on belt with the M5 tension screw.
4.	If present, remove the tape seal brackets. It may be necessary to release the tension on the tape seals first. In this case, slide the top plate laterally after removing screws from the top plate and front cover to release the tension on the tape seals and allow the front cover to be removed. It is not necessary to remove the tape seal tension brackets from the top of the Z carriage.
5.	Replace the Z stage one belt. When hooking the belt around the Z motor pulley, make sure that the belt is inside the flanges on the Z motor pulley.
6.	Adjust the belt tension per above, and replace the parts.
7.	Recalibrate the robot.

Replacing the Z Column Stage Two Timing Belt

 DANGER Electrical Shock	
Before replacing the power supplies, the AC power should be removed.	

Tools Required

- 2.0 mm hex driver
- 3.0 mm hex L wrench

- 3.0 mm hex driver
- 4.0 mm ball end hex driver

Spare Parts Required

- J2 Stage One Belt, PN PFD0-MC-X0006 (500 mm, 1000 mm, 1420 mm stroke)

To replace the Z column stage two timing belt, perform the following procedure.

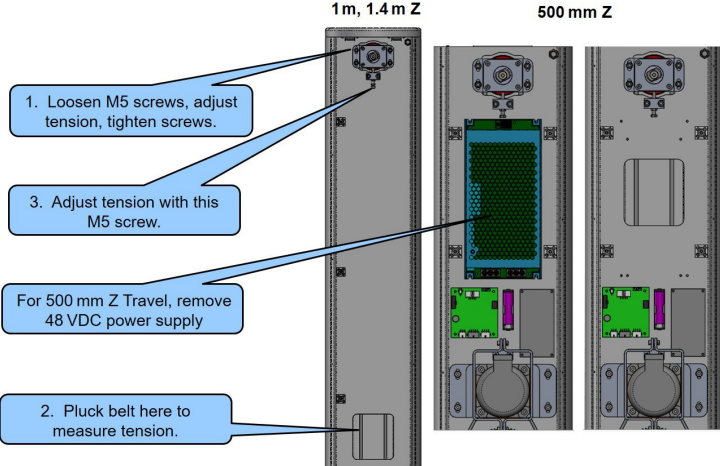
Step	Action
1.	Move the Z carriage to 640 mm height for the 1000 mm and 1420 mm Z travel robots, or 380 mm height for the 500 mm Z travel robot.
2.	Turn off the robot power and remove the AC power cord.
3.	<p>Remove the curved rear cover from the Z column.</p>  <p>The diagram illustrates the Z column assembly for two different travel distances: 1m, 1.4m Z and 500mm Z. It shows the internal components, including the timing belt, motor, and various adjustment points. Callouts provide specific instructions for adjusting tension and handling the power supply for the 500mm Z travel robot.</p>
4.	Remove the top plate and front Z cover. If tape seals are present, slide the top plate laterally after removing screws from the top plate and front cover to release the tension on the tape seals and allow the front cover to be removed. It is not necessary to remove the tape seal tension brackets from the top of the Z carriage.
5.	Support the Z carriage and links with a stick, boxes, or other means to prevent it from dropping when the belt clamp is removed.
6.	For the 500 mm Z travel robot, remove the 48VDC power supply.
7.	Remove the Z belt clamp which should be accessible through the access cutout in the Z extrusion, change the Z belt, and replace the clamp.
8.	Tension the Z belt per above.
9.	Replace the parts.

Step	Action
10.	Recalibrate the robot.

Recovering from Corrupted PAC Files

PAC files are configuration files that determine the configuration of the robot for the software, including the robot factory calibration data. These files are stored in Flash RAM. Flash RAM is also used to store robot programs. The Flash RAM requires some time for a complete write cycle. During the write cycle, the console will display a flashing warning not to turn off robot power. If robot power is turned off during the Flash RAM write cycle, the Flash data may be lost or corrupted. If this happens, it is necessary to reload both the robot PAC files and any user programs that were stored in Flash RAM. This problem should typically not be encountered by a user unless the user is changing configuration files in the robot and fails to wait a sufficient amount of time for the flash to be saved before turning off power.

Brooks maintains a record of PAC files shipped with each robot Serial Number. If the PAC files have been corrupted, it is possible to get a backup copy from Brooks. Email support@preciseflex@brooksautomation.com for backup copies. The backup copy will contain the factory configuration and calibration data, but will not contain any changes, including any new calibration data, made after the robot has left the factory.

In order to allow the controller to recover from corrupted PAC files, a set of recovery boot up PAC files is loaded in the system area of the Flash.

To configure the controller to boot up in recovery mode, complete the following steps:

Step	Action
1.	Obtain a set of backup PAC Files from Brooks or a local backup. Email support@preciseflex@brooksautomation.com for backup copies.
2.	Remove the screws holding the connector panel in the base of the robot to access the PCA.

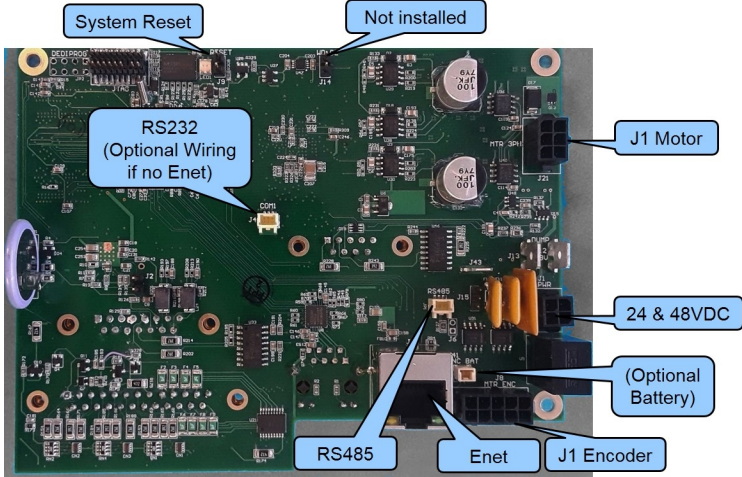
Step	Action
3.	<p>Move Jumper J9 (System Reset) so that it connects the two jumper posts. This will cause the factory default configuration files to be loaded at controller boot up.</p> 
4.	Cycle robot power to reboot the controller.
5.	Follow the procedure above for updating PAC files.

Replacing the Outer Link Motors or Harmonic Drives in the c8A

DANGER
Electrical Shock

Before replacing any parts, the AC power should be disconnected. Removing the front cover allows access to the AC power terminals.



Tools Required

- 3.0 mm hex driver
- 2.5 mm hex driver
- 2.0 mm hex driver

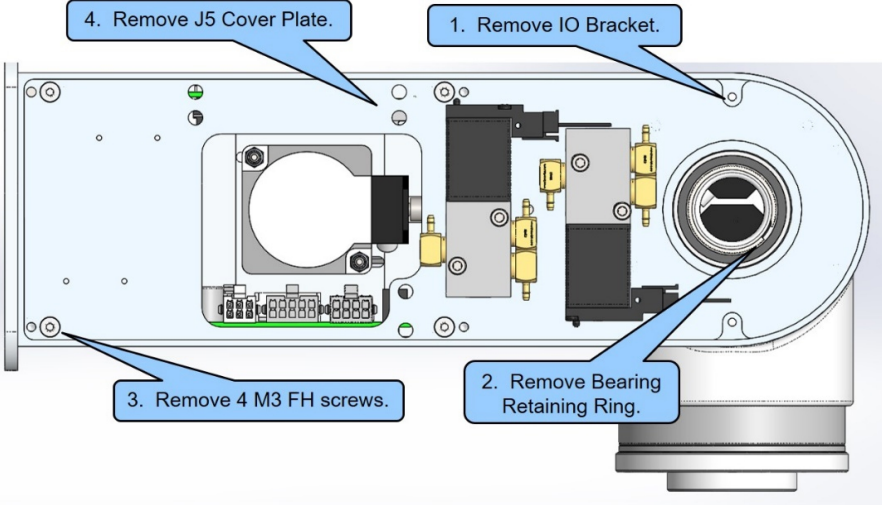
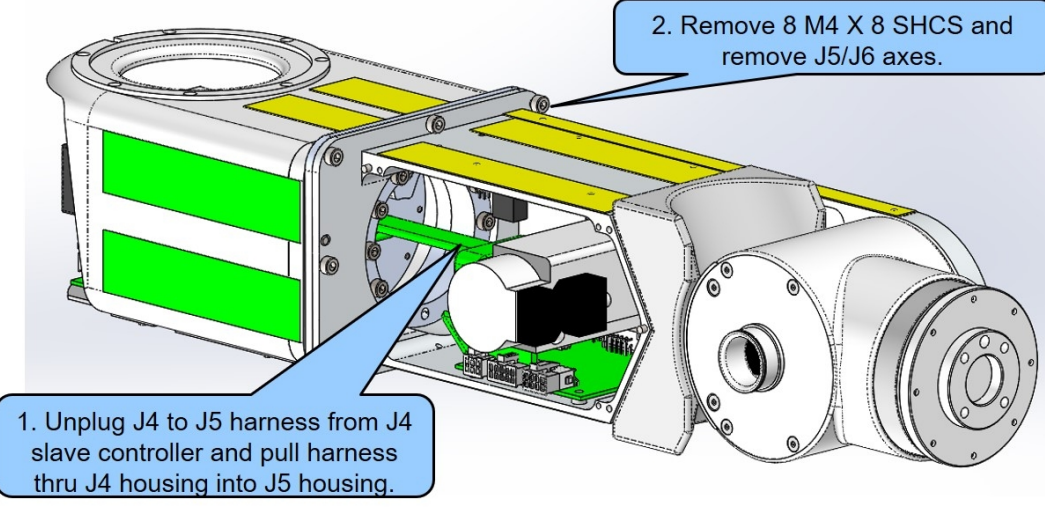
The motors and harmonic drives in c8A are not items that can be replaced in the field. There are two major subassemblies in the c8A outer link. These are the J5/J6 assembly and the J4 assembly. These are factory replacement items. In order to replace one of these assemblies in the c8A, follow this procedure.

Step	Action
1.	Remove the covers from the outer link, including J4 and J5.
2.	Remove the J5 cover plate from the J5/J6 axes.
3.	Unplug the J4 to J5 harness from the J4 slave amplifier, and pull the harness through J4 into the J5 housing.
4.	Remove the J5/J6 axes from J4 by removing the (8) M4 X 8 SHCS.
5.	<p>At this point the J5/J6 assembly may be returned to the factory and a new assembly attached.</p>  <p>4. Remove J5 Cover Plate.</p> <p>1. Remove IO Bracket.</p> <p>2. Remove Bearing Retaining Ring.</p> <p>3. Remove 4 M3 FH screws.</p>
6.	 <p>2. Remove 8 M4 X 8 SHCS and remove J5/J6 axes.</p> <p>1. Unplug J4 to J5 harness from J4 slave controller and pull harness thru J4 housing into J5 housing.</p> <p>To replace the J4 assembly, the M5 screws which attach the J4 housing to the J3 output shaft must be removed, at which point the J4 assembly may be returned to the factory and an replacement may be installed.</p>

Replacing the Robot Main Controller

 DANGER Electrical Shock	
<p>Before replacing the Robot Controller, the AC power should be removed.</p>	

Tools Required:

- 2.5 mm hex driver or hex L wrench
- 2.0 mm hex driver or hex L wrench
- 5.0 mm socket driver

Spare Parts Required for main robot controller

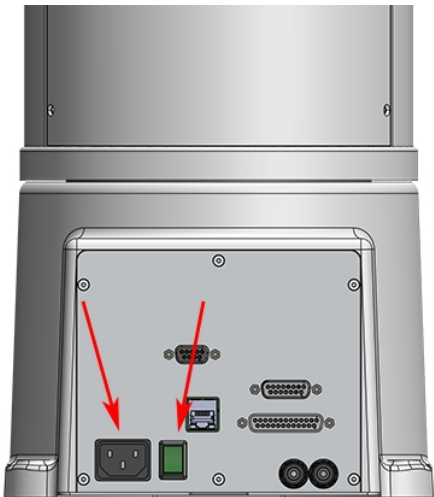

- PreciseFlex PFD0X Controller - P/N 890242-0001

Prior to replacing the controller, if the controller will boot up, the user may wish to make copies of both the robot PAC files (config directory), any project files (projects directory), and the “Sys” files (sys directory), to a PC. These files can be copied using <ftp://192.168.0.1/flash> or the IP address of the controller. To replace the robot controller, follow this procedure.

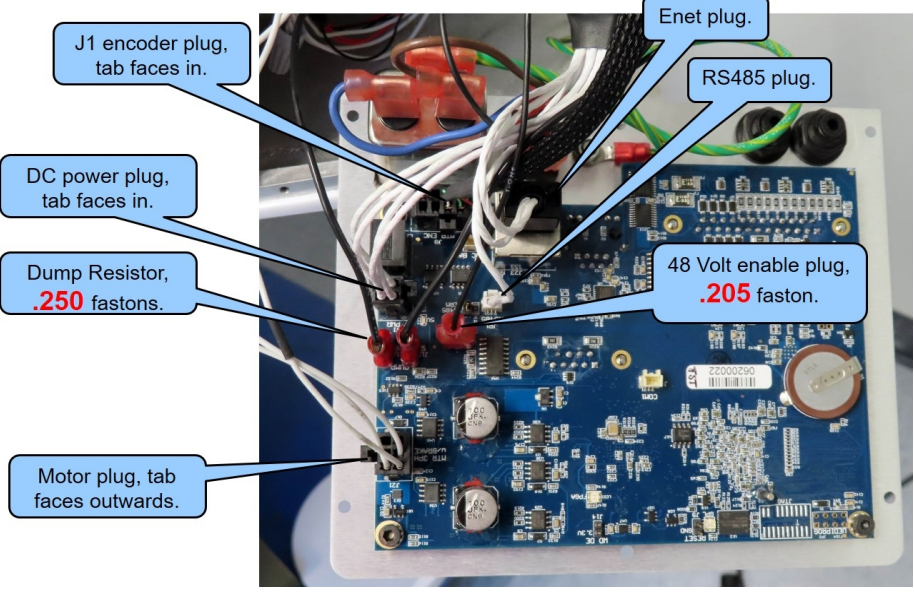
Step	Action
1.	<p>On the Facilities Panel, turn off the robot power and remove the AC power cord.</p> 

Step	Action
2.	<p>Remove the connector panel from the base of the robot by removing M3 X 6 mm flat head screws.</p> 
3.	<p>Remove the main robot controller -- PreciseFlex PFD0 Controller PNPFD0-EA-00001-3 -- by removing the (3) M3 X 8 mm SHCS and the D-Sub standoffs from the connector side of the panel.</p>
4.	<p>Replace the controller and connect the wires as shown above.</p>
5.	<p>Replace the connector panel.</p>
6.	<p>Reload the robot PAC files (config directory), any project files (projects directory), and the "Sys" files (sys directory), from a PC. These files can be copied using ftp://192.168.0.1/flash or the IP address of the controller.</p>
7.	<p>Recalibrate the robot.</p> <div style="border: 1px solid black; padding: 5px;"> <p>FTP directory /flash/ at 192.168.0.1</p> <p>To view this FTP site in File Explorer: press Alt, click View, and then click Open FTP Site in File Explorer.</p> <p>Up to higher level directory</p> <pre> 01/01/1970 12:00AM Directory . 04/13/2020 02:41PM Directory .. 01/27/2020 05:19PM Directory config 04/03/2020 03:35PM Directory projects 04/03/2020 03:34PM Directory sys </pre> </div>

Replacing the Z-axis Slave Controller

 DANGER Electrical Shock	
Before replacing any Controller, the AC power should be removed.	

Tools Required

- 2.0 mm hex driver
- 2.5 mm hex driver

Spare Part Required:



- GSB4X Board - P/N 589629-0001

To replace the Z axis slave controller, follow this procedure.

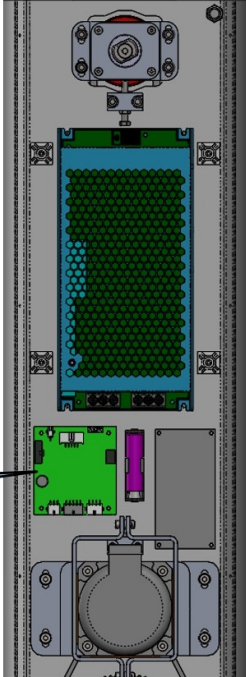
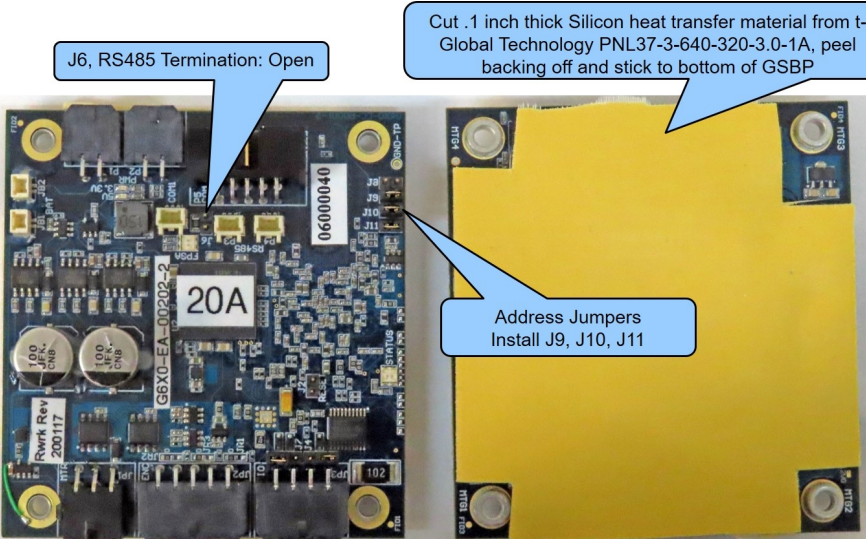
Step	Action
1.	Turn off the robot power and remove the AC power cord.
2.	Remove the curved rear cover from the Z column.
3.	Remove the GSB4X slave amp by removing the (4) M3 X 10 mm SHCS and unplugging the cables.
4.	Replace the slave controller and re-attach the harness.
5.	Set the jumpers correctly for the address and termination.
6.	Replace the curved rear cover.

Step	Action
7.	<p>Recalibrate the robot.</p> 
8.	 <p>J6, RS485 Termination: Open</p> <p>Cut .1 inch thick Silicon heat transfer material from t-Global Technology PNL37-3-640-320-3.0-1A, peel backing off and stick to bottom of GSBP</p> <p>Address Jumpers Install J9, J10, J11</p>

Replacing the J3 Axis Slave Controller

 DANGER Electrical Shock	
Before replacing any Controller, the AC power should be removed.	

Tools Required

- 2.5 mm hex driver

Spare Part Required

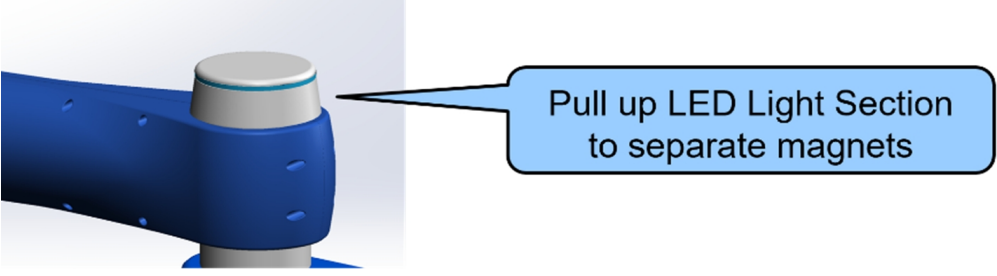

- GSB4X Board - P/N 589629-0001

To replace the J3 axis slave controller, perform the following procedure.

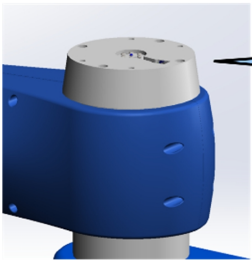
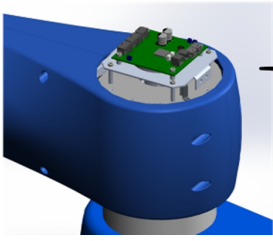
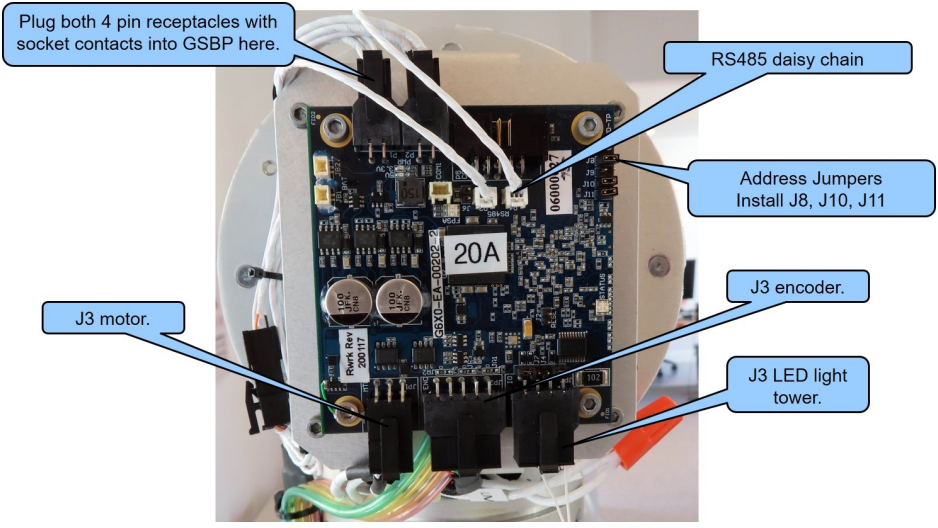
Step	Action
1.	Turn off the robot power and remove the AC power cord.
2.	Remove the LED light tower cover by pulling up on the light section to release magnets.
3.	Remove the LED light tower body by removing the (4) M3 X 40 mm SHCS. Unplug LED pigtail.
4.	Replace the slave controller and re-attach the harness.
5.	Set the jumpers correctly for the address and termination.
6.	Replace the LED light tower parts.
7.	<p>It is not necessary to recalibrate the robot if only this controller is replaced.</p> 

Step	Action
8.	 <p>Remove 4 M3 X 40 SHCS to remove LED tower body</p>
9.	 <p>Replace J3 slave controller</p>
10.	 <p>Plug both 4 pin receptacles with socket contacts into GSBP here.</p> <p>RS485 daisy chain</p> <p>Address Jumpers Install J8, J10, J11</p> <p>J3 encoder.</p> <p>J3 LED light tower.</p> <p>J3 motor.</p>

Replacing the J4 or Gripper Slave Controller in c10

 DANGER Electrical Shock	
Before replacing any Controller, the AC power should be removed.	

Tools Required

- 2.5 mm hex driver

Spare Parts Required:

- GSB4X Board for J4 axis - P/N 589629-0001
- 60 N gripper (10 A differential encoder) - P/N 389629-0002
- 23 N gripper (10 A single-ended encoder) - P/N 389629-0003

To replace the J4 or gripper slave Controller in the c10, perform the following procedure.

Step	Action
1.	Turn off the robot power and remove the AC power cord.
2.	Remove the covers from the outer link.
3.	Remove the sheet metal cover from the outer link.
4.	Replace the slave controller (GSB4X).
5.	Set the jumpers correctly for the address and termination.
6.	Recalibrate the robot.

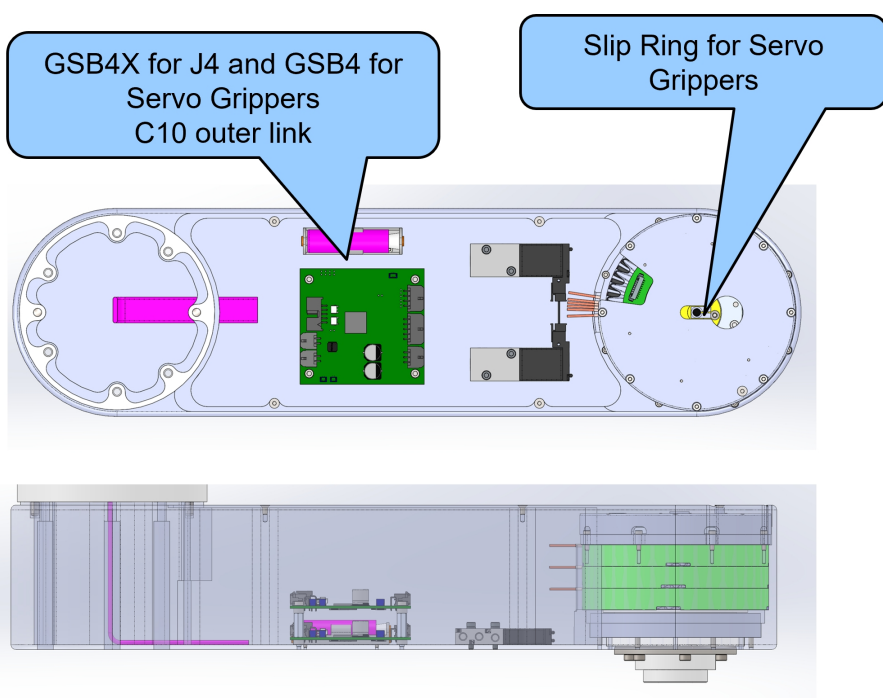
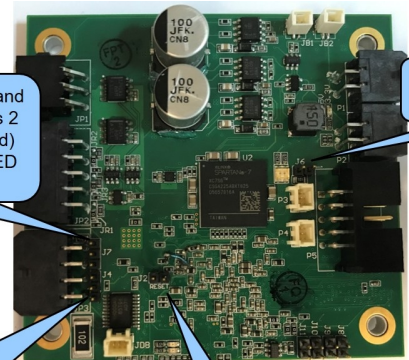
Step	Action
7.	<p>Replace the covers.</p>  <p>GSB4X for J4 and GSB4 for Servo Grippers C10 outer link</p> <p>Slip Ring for Servo Grippers</p>
8.	 <p>Jumper J7: connect pins 1 and 2 for TX input, connect pins 2 and 3 (towards top of board) to connect DOUT3, with LED drive resistor.</p> <p>Jumper J4: connect pins 1 and 2 for RX input, connect pins 2 and 3 (towards middle of board) to connect DIN1.</p> <p>Reset, leave open.</p> <p>RS485 Jumper: J6 open if servo gripper, closed if not.</p> <p>Address Jumpers: J10 installed, J8, J9, J11 open.</p> <p>GSB4 for J4 Axis, c10</p>

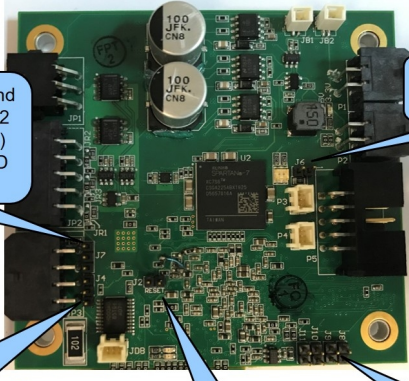
Step	Action
9.	 <p>Jumper J7: connect pins 1 and 2 for TX input, connect pins 2 and 3 (towards top of board) to connect DOUT3, with LED drive resistor.</p> <p>Jumper J4: connect pins 1 and 2 for RX input, connect pins 2 and 3 (towards middle of board) to connect DIN1.</p> <p>RS485 Jumper: J6 closed for servo gripper on 4 axis.</p> <p>Reset, leave open.</p> <p>Address Jumpers: J8, J9 installed, J10, J11 open.</p> <p>GSB4 for 23 N or 60 N Gripper (c10).</p>

Replacing the Gripper and Slip Ring in the c10



DANGER
Electrical Shock

Before replacing any Controller, the AC power should be removed.



Tools Required

- 1.5 mm hex driver
- 2.0 mm hex driver
- 2.5 mm hex driver

Spare Parts Required:

- 60 N standard gripper slip ring - P/N 627540
- 23 N standard gripper slip ring - P/N 627487

To replace the gripper or slip ring, perform the following procedure.

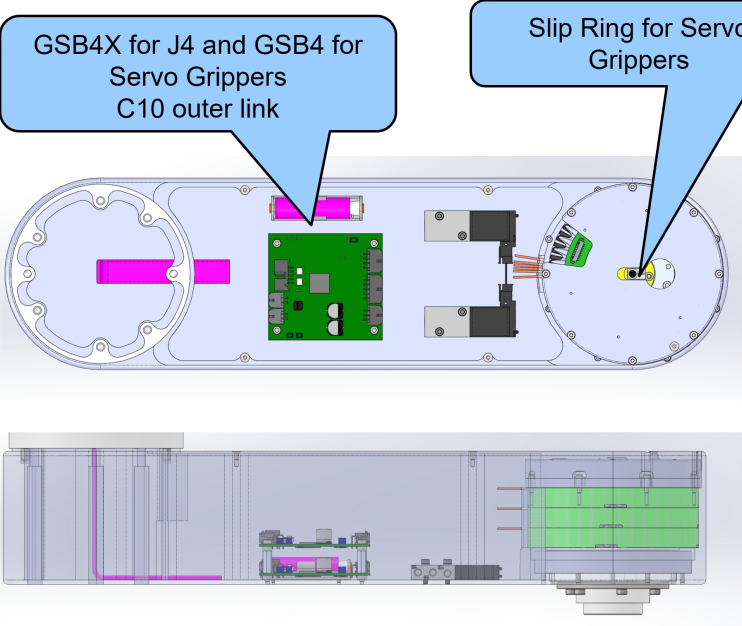
Step	Action
1.	Turn off the robot power and remove the AC power cord.
2.	Remove the covers from the outer link.
3.	Remove the sheet metal cover from the outer link.
4.	Remove cover, slip ring and mount, and slip ring.
5.	Remove the (6) M2 X 10 mm SHCS to release gripper, then unplug slip ring connectors in gripper.
6.	At this point, the gripper or the slip ring can be replaced.
7.	Reassemble the parts. Be careful not to pinch the slip ring cable, it fits in the notch in the flange.
8.	<p>The robot does not need to be re-calibrated after changing the slip ring or gripper.</p> 

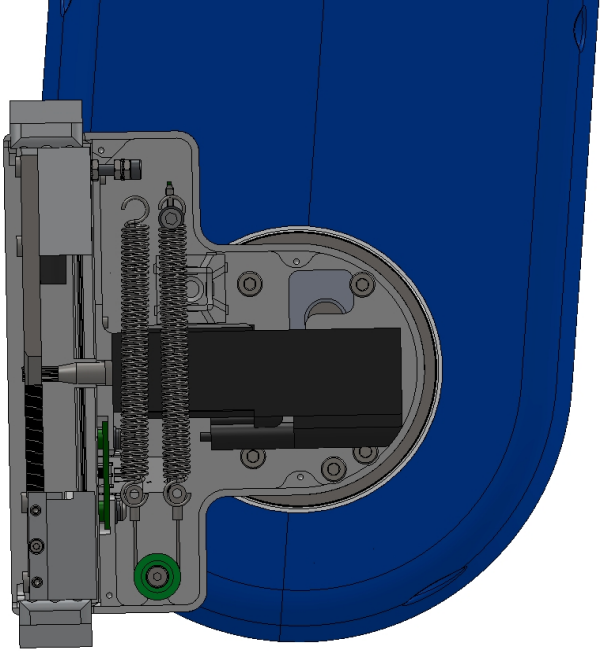
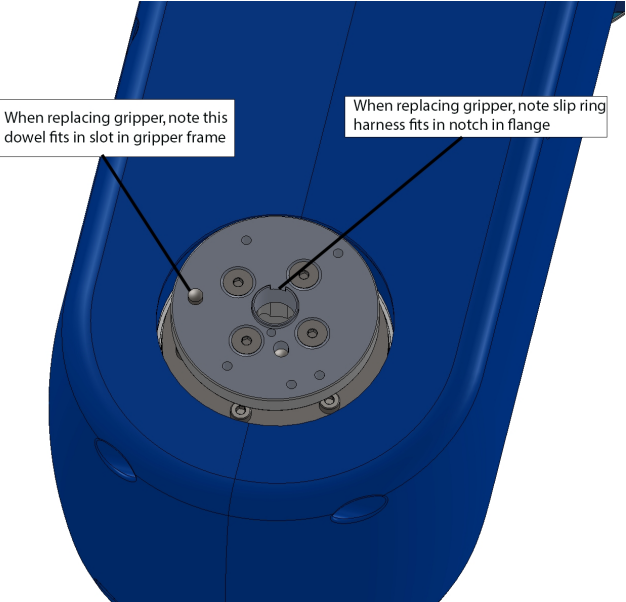
Step	Action
9.	<p>Remove the gripper cover. Remove 6 M2 X 10 SHCS to remove the gripper, then unplug the slip ring connectors in the gripper to free the gripper.</p> 
10.	Unplug the slip ring connectors.
11.	Remove the M4 x 10 SHCS mounting gripper to gripper adaptor flange to free the gripper.
12.	 <p>When replacing gripper, note this dowel fits in slot in gripper frame</p> <p>When replacing gripper, note slip ring harness fits in notch in flange</p>

Adjusting the Gripper Backlash or Centering Fingers

Tools Required

- 1.3 mm “stubby” hex L wrench
- 1.5 mm “stubby” hex L wrench

Spare Parts Required

- None

To adjust the gripper backlash or center fingers, perform the following procedure.

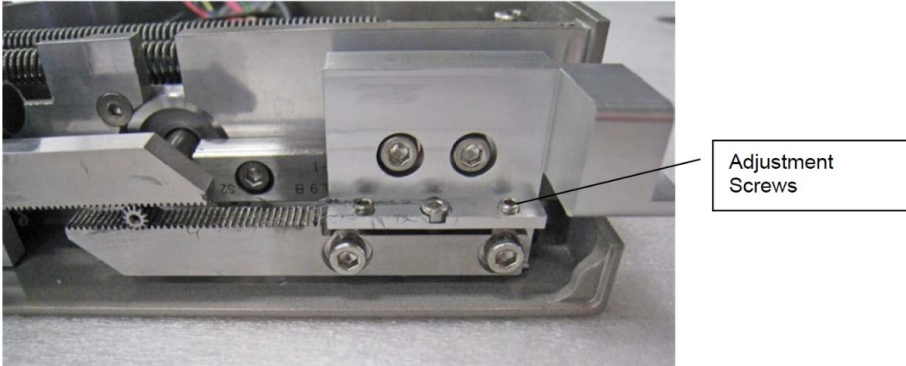
Step	Action
1.	Remove the gripper cover by removing the (6) M2 X 6 mm FHCS.
2.	For grippers with spring return, disconnect one end of the spring to remove the spring tension.
3.	Move the racks back and forth to determine which rack has backlash and where it is located on the rack.
4.	Loosen the (2) M3 X 8 mm SHCS that clamp the rack to the finger mount.
5.	Adjust the M2 SHCS and M3 set screws to adjust the rack backlash or center the racks as needed if a crash has caused the racks to skip teeth or come loose.
6.	Remove the (2) M3 X 8 mm SHCS one at a time, apply Loctite 243 to the screwlock, and reinstall/tighten the screws. 

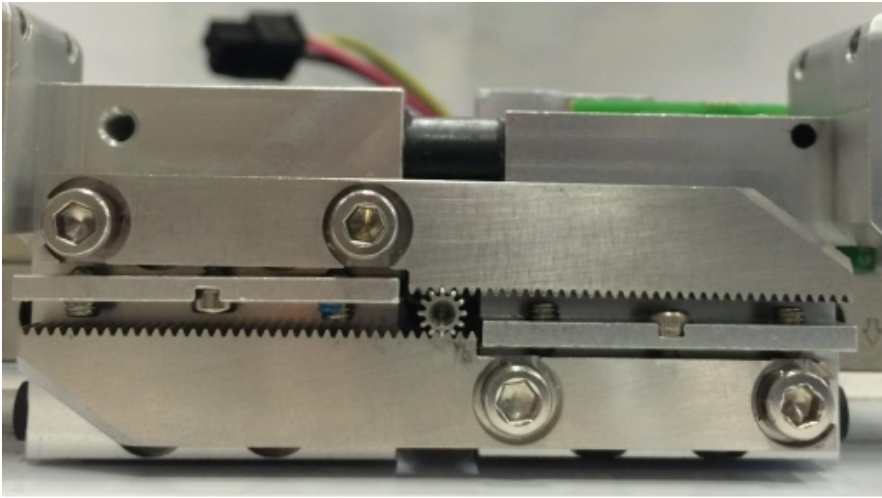
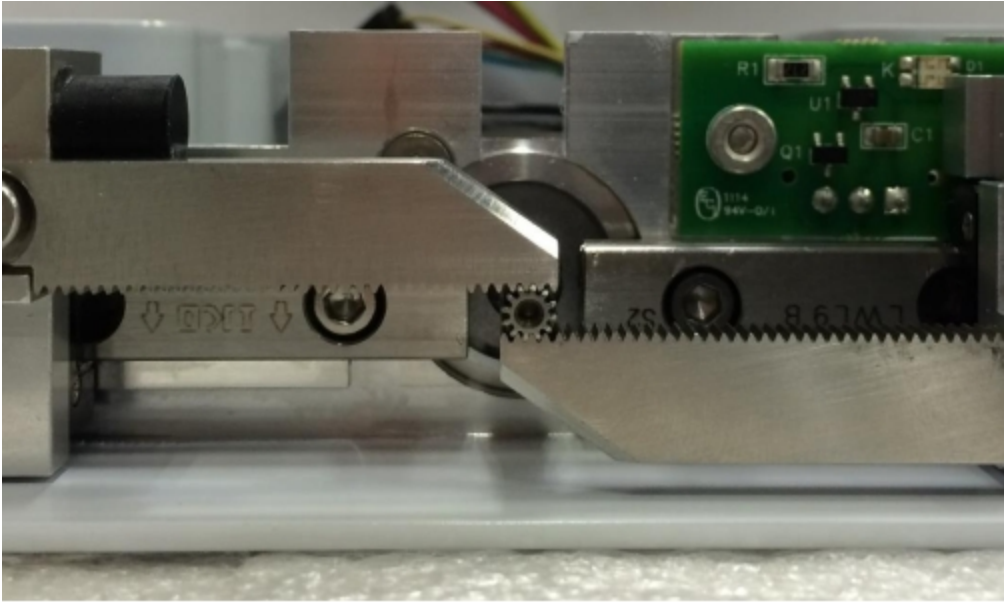
Step	Action
7.	 <p data-bbox="305 772 889 804">Gripper racks centered in fully closed position</p>
8.	 <p data-bbox="305 1449 868 1480">Gripper racks centered in fully open position</p>

Replacing the Main Harness

Replacement of the Main Robot Harness is typically only performed at the factory. The Main Robot Harness is intended to last for the life of the robot.

Replacing the J3 Clock Spring Harness to the J4 Motor

Tools Required

- 2.0 mm hex driver
- 2.5 mm hex driver

Spare Parts Required

- Assy, Cable, J3 Clockspring, PFD0 - P/N 389639

To replace the J3 clock spring harness to the J4 Motor, perform the following procedure.

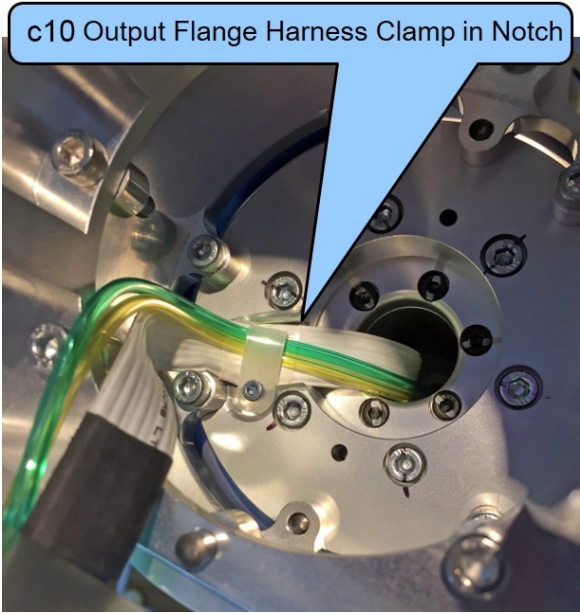
Step	Action
1.	Remove the LED light tower and J3 Slave Controller per instructions for these assemblies.
2.	For the c10, remove the covers, the bottom cover, the sheet metal bottom cover, and the sheet metal top cover to expose the harness.
3.	For the c10, unplug the end of the clockspring harness from the J4 slave controller in the outer link, then remove the outer link from the J3 spacer by removing the (6) M5 X 12 mm SHCS.
4.	For the c10, remove the harness clamp from the J3 output flange to release the outer link end of the harness. 
5.	For the c8A, remove the J4 end cover and unplug the J4 end of the clock spring harness from the J4 slave amp (GSB4X).

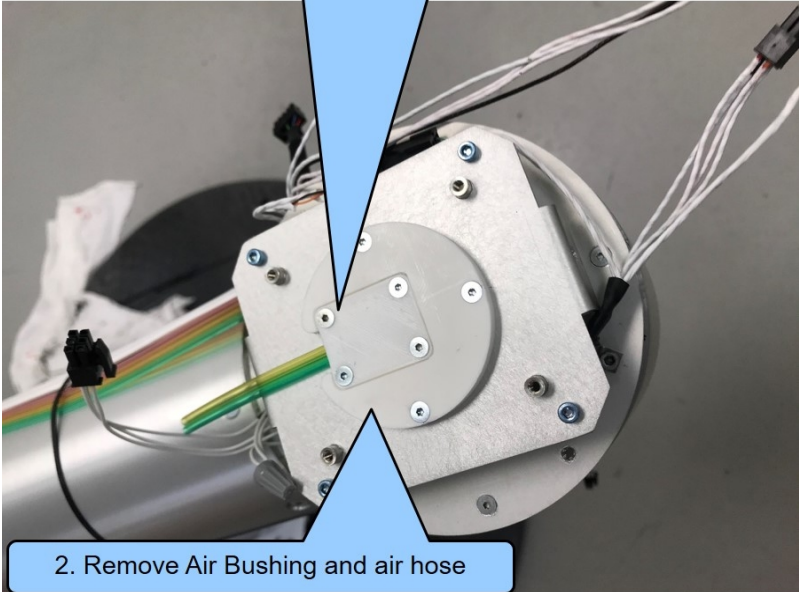
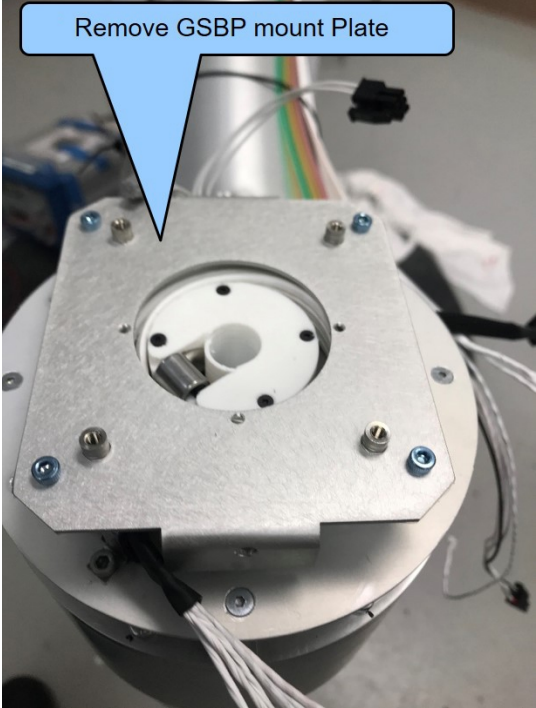
Step	Action
6.	<p>Remove the air hose clamp plate and thru hole bushing and pull the air hose up through J3.</p> <p>1. Remove Air Bushing Clamp Plate</p>  <p>2. Remove Air Bushing and air hose</p>
7.	<p>Remove GSBP mount Plate</p> 

Step	Action
8.	 <ol style="list-style-type: none"> 1. To remove harness, do these operations in reverse. Make sure you are completely clockwise against the hard stop looking from the top. Route so there is a total of four wraps 2. Clamp with Cable Clamp, Clip, J3 (PFD0-MC-M0132), neoprene strip, M3-10 FHCS and Loctite 222. 3. Install Lid, Bushing, J3 so it constrains the harness folded over going down elbow. Fasten with M2-6 FHCS Alloy and Loctite 222.
9.	Remove the clockspring harness as shown in the previous step, and install the new harness. <i>For the 10c it is important to ensure that the harness is clamped in the notch in the J3 output flange as shown, or the J4 motor will interfere with the harness.</i>
10.	Replace the parts.
11.	For the c8A, it is not necessary to recalibrate the robot as the J3 encoder is a single turn absolute encoder and the J3 slave amp does not require an external battery.

Replacing the J4 to Gripper Controller Harness in the c10

Tools Required

- 2.0mm hex driver
- 2.5mm hex driver

Spare Parts Required:

- Assy, Cable, J5, PFD0 - P/N 389637

To replace the J4 to gripper controller harness in the c10, perform the following procedure.

Step	Action
1.	Remove the covers and the sheet metal top cover from the outer link.

Step	Action
2.	Replace the harness between the J4 slave controller and the gripper controller.
3.	Replace the covers. It is not necessary to recalibrate the robot.

Replacing the J4 slave controller in the c8A

Tools Required

- 2.0 mm hex driver
- 2.5 mm hex driver
- 5.0 mm hex socket driver

Spare Parts Required:

- GSB4X boards - P/N 589629-0001

To replace the J4 slave controller in the c8A, perform the following procedure.

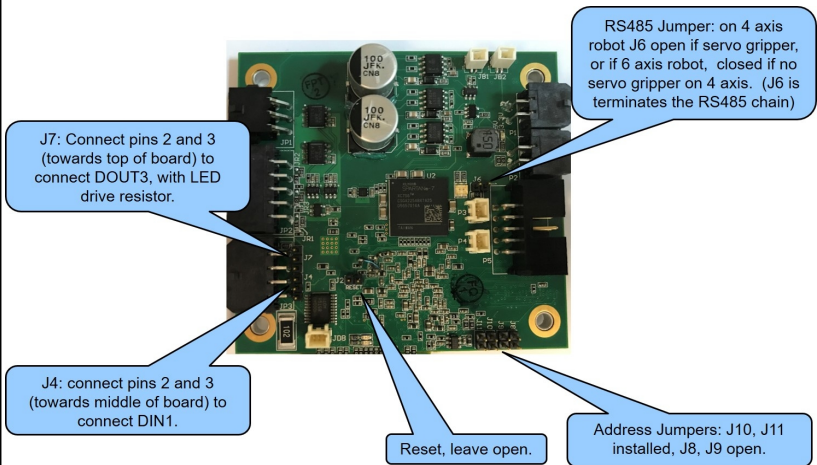
Step	Action
1.	Remove the end cover from J4 and the bottom cover from J4.
2.	Remove the J4 controller mount plate from the bottom of J4.
3.	Unplug the J3 to J4 harness and the J4 to J5 harness and the motor connectors.
4.	Replace the J4 slave controller (GSB4X).
5.	Replace the parts.
6.	<p>Recalibrate the robot.</p>  <p>The diagram shows a green printed circuit board (PCB) for the GSB4X slave controller. It features several components and connectors: <ul style="list-style-type: none"> J7: A connector on the left side of the board. A callout indicates: "J7: Connect pins 2 and 3 (towards top of board) to connect DOUT3, with LED drive resistor." J4: A connector on the left side, lower than J7. A callout indicates: "J4: connect pins 2 and 3 (towards middle of board) to connect DIN1." RS485 Jumper: A small component on the right side. A callout indicates: "RS485 Jumper: on 4 axis robot J6 open if servo gripper, or if 6 axis robot, closed if no servo gripper on 4 axis. (J6 is terminates the RS485 chain)" Reset: A small component at the bottom center. A callout indicates: "Reset, leave open." Address Jumpers: A set of jumpers on the right side. A callout indicates: "Address Jumpers: J10, J11 installed, J8, J9 open." </p>

Replacing the J6 Motor Pigtail Harness

Tools Required

- 2.0 mm hex driver
- 2.5 mm hex driver

Spare Parts Required

- J6 Motor and Encoder Pigtail - P/N 389633

To replace the J6 motor pigtail harness, perform the following procedure.

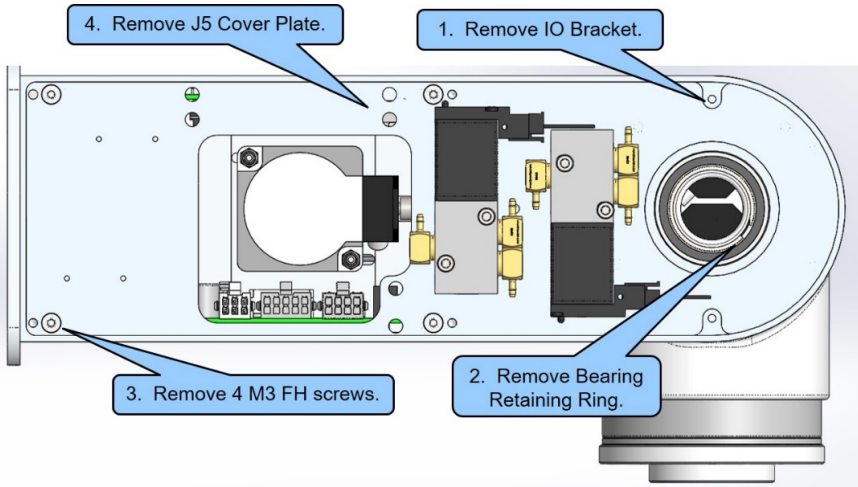
Step	Action
1.	Remove the covers from J5, the IO harness bracket, and the J5 cover plate, threading the J6 motor pigtail harness thru the 25 mm bearing.
2.	Remove the J6 cover plate, replace the harness, tie wrap per below, and replace the parts.
3.	Recalibrate the robot. 

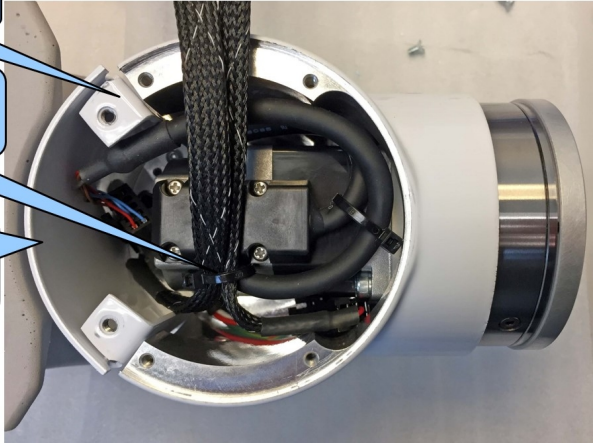
Step	Action
4.	<p data-bbox="300 275 571 310">1. Remove J6 cover plate.</p> <p data-bbox="300 359 571 436">2. Replace J6 Motor and Encoder Pigtail, add tie wrap for strain relief here.</p> <p data-bbox="300 506 571 604">3. Thread J6 Motor and Encoder Pigtail, through cover plate, replace J6 cover plate and other parts.</p> 

Appendices

Appendix A: c8A Product Specifications

General Specification	Range
PERFORMANCE	
Payload	8 kg
Max Cartesian Speed	500 mm/sec, horizontal plane, X/Y direction, 600 mm/sec, Z direction
Max Joint Speed	J1 200°/sec J2 600 mm/sec J3 360°/sec J4 360°/sec J5 200°/sec J6 360°/sec
Max Acceleration	5000 mm/sec ² with 6 kg payload
Repeatability	± 0.020 mm at tool flange center
RANGE OF MOTION	
Joint 1 (base)	± 168°
Joint 2 (Z-axis)	500, 1000, 1420 mm
Joint 3 (Elbow)	+12° to +348°
Joint 4	+100° to -220°
Joint 5	± 110°
Joint 6	± 295°
Horizontal Reach	(Horizontal Reach) 896 mm with Joint 5 at 90° (Horizontal Reach) 985 mm with Joint 5 at 0°
COMMUNICATIONS	
General	100 Mb Ethernet, TCP/IP EtherNet/IP Modbus/TCP
Operator Interface	Web-based operator interface
Digital I/O	12 inputs, 8 outputs at base of robot Optically isolated, 24 V @ 100 mA Remote I/O available
FACILITIES	
Power	90 to 264 VAC, auto selecting, 50-60 Hz 70-175 watts typical operation DC Power Option Available

General Specification	Range
Pneumatics	Two 3.2 mm OD (1.7 mm ID) airlines provided for end-of-arm-tooling 4.9 bar max (71 PSI)
E-Stop	Dual Channel
Controller Mounting	Embedded into robot base
Air Lines	Two, 3.2 mm OD, 1.6 mm ID, max pressure 500 kpa (75 psi)
Weight	46 kg (500 mm Z-axis) 55 kg (1000 mm Z-axis) 65 kg (1420 mm Z-axis)
Noise Level	< 50 dB(A)
SOFTWARE	
Programming	Programming via Guidance Development Studio (GDS) Guidance Programming Language (GPL) TCS API
Enhanced Functions	Hand Guiding Teaching (standard)
PERIPHERALS AND ACCESSORIES	
General	Remote I/O (RIO)
TEMPERATURE	
Indoor	For indoor use only
Ambient Temperature	0°C to 40°C
Humidity Range	10 to 75%, non-condensing, non-corrosive
Storage and Shipment Temperature	-25°C to +55°C

Appendix B: c10 Product Specifications

General Specification	Range
PERFORMANCE	
Payload	10 kg
Max Cartesian Speed	500 mm/sec in horizontal plane 600 mm/sec in z-direction
Max Joint Speed	J1 - 200°/sec J2 - 600 mm/sec J3 - 360°/sec J4 - 540°/sec
Max Acceleration	5000 mm/sec ² with 6 kg payload
Repeatability	± 0.020 mm at tool flange center
RANGE OF MOTION	
Joint 1 (base)	± 168°
Joint 2 (Z-axis)	500, 1000, 1420 mm
Joint 3 (Elbow)	+ 12° to +348°
Joint 4	± 240°
Horizontal Reach	896 mm
COMMUNICATIONS	
General	100 Mb Ethernet, TCP/IP Modbus/TCP RS232 at end-of-arm
Operator Interface	Web-based operator interface
Digital I/O	12 inputs, 8 outputs at base of robot Optically isolated, 24 V @ 100 mA 2 in, 4 out for end-of-arm tooling Remote I/O available
FACILITIES	
Power	90 to 264 VAC Auto selecting, 50-60 Hz 100-250 watts typical operation
Pneumatics	Two 3.2 mmOD (1.7 mm ID) airlines provided for end-of-arm-tooling. 4.9 bar max (71 PSI)
E-Stop	Dual channel

General Specification	Range
Controller Mounting	Embedded into robot base
Weight	44 kg (500 mm Z-axis) 53 kg (1000 mm Z-axis) 63 kg (1420 mm Z-axis)
Noise Level	< 50 dB(A)
SOFTWARE	
Programming	Programming via Guidance Development Studio (GDS) Guidance Programming Language (GPL) TCS API
Enhanced Functions	Hand-guided teaching XY compliance (optional) Z-Height detection (optional)
PERIPHERALS AND ACCESSORIES	
General	IntelliGuide s23 gripper IntelliGuide s60 gripper IntelliGuide s23D gripper (Dual) Remote I/O (RIO)
Vision	IntelliGuide v23 Vision IntelliGuide v60 Vision
TEMPERATURE	
Indoor	For indoor use only
Ambient Temperature	0°C to 40°C
Humidity Range	10 to 75%, non-condensing, non-corrosive
Storage and Shipment Temperature	-25°C to +55°C

Appendix C: Environmental Specifications

The c8A and c10 Robots must be installed in a non-condensing environment with the specifications from the table below.

General Specification	Range & Features
Indoor use only	
Ambient temperature	4° C to 40° C
Storage and shipment temperature	-25° C to +55° C
Humidity range	10 to 90%, non-condensing
Altitude	Up to 2000 m
Voltage	100-240 VAC +/- 10%, 50/60 Hz
Mains cord rating, min	16 AWG, 3 conductor, 10 Amps min
Pollution Degree	2
Approved Cleaning Agents	IPA, 70% Ethanol/30% water, H2O2 Vapor up to 1000 ppm
IP Rating without Tape Seal Option	1P1X
IK Impact Rating	IK08: 5 Joule

Appendix D: Spare Parts List

NOTE: For help replacing spare parts, email support_preciseflex@brooksautomation.com

Reference - the serial number format is:

- FD0-yymm-XY-zzzzz
- Yy – year
- Mm – month
- X – controller rev
- Y – robot rev
- Zzzzz – unique number

Description	Part Number
23 N Gripper Standard Slip Ring, Dual and Single Gripper	627487
24 VDC Supply	PS10-EP-24150
48 VDC Motor Supply	PS10-EP-481000
60 N Gripper Standard Slip Ring	627540
Absolute Encoder Battery, 3.6 V Lithium Battery	G1S0-EC-X0007
Assembly, J4, HD PFD0 (support_preciseflex@brooksautomation.com)	Contact Help Desk
Assembly, J5 & J6, HD, PFD0 (support_preciseflex@brooksautomation.com)	Contact Help Desk
Energy Dump Resistor Assembly	389641
J2 600 W Motor Assy	623833
J2 Stage 1 Belt	PFD0-MC-X0006
J2 Stage 2 Belt 500 mm (1.4 M)	PFD0-MC-X0003
J2 Stage 2 Belt 1000 mm (2.4 M)	PFD0-MC-X0003
J2 Stage 2 Belt 1420 mm (3.24 M)	PFD0-MC-X0003
J3 Clockspring Harness	389639
J4 to Gripper Harness in PFDD4	389637
J4 to J5 Harness in c8A	389644
J4 Stage 1 Belt	PFD0-MC-X0050
J4 Stage 2 Belt	PFD0-MC-X0051
J5 to J6 Harness in c8A	389637
J6 Motor and Encoder Pigtail	389633
Main Controller with Complex Kinematics License	390242-0001
O-Rings for Front Cover dowel pins (2)	Not available
PF400 23 N Servo Gripper with Spring, without fingers	PF0S-MA-00001-2
Secondary Controller GSBP 20 A with motor connector pigtail and thermal pad for Z	389629-0004
Secondary Controller GSBP 28.57 A n	589629-0001
Secondary Controller GSBP 10 A single ended for 23 N grip	389629-0003
Slave Controller GSBP 10 A single ended for 23 N grip	389629-0003
Slave Controller GSBP 20 A no thermal pad	589629-0001
Slip Ring Harness Assembly, 23 N Spring Gripper	397515

Description	Part Number
Slip Ring Harness Assembly, 23 N Spring Gripper Vision	398215
Slip Ring Harness Assembly, 23 N IntelliGuide Vision Gripper	627468
Slip Ring Harness Assembly, 60 N Spring Gripper	PF04-MA-00030-E2
Slip Ring Harness Assembly, 60 N IntelliGuide Vision Gripper	627235
Slip Ring Harness Assembly, 60 N Spring Gripper Vision	600186
Solenoid Valve	PF05-MC-X0001

Appendix E: Preventative Maintenance

Every one to two years, perform the following preventative maintenance procedures. For robots that are continuously moving 24 hours per day, 7 days a week at moderate to high speeds, a one-year schedule is recommended. For robots with low duty cycles and low to moderate speeds, these procedures should be performed at least once every two years.

	Procedure If Problem Detected
Check all belt tensions.	Re-tension if necessary.
Check air harness tubing in elbow if present, and theta axis for any wear.	Replace if necessary.
Check second stage (long) Z belt for any squeaking.	If noisy, add thick grease to front and rear edge of belt if necessary. (Shell 222 XP or similar). Z timing belt can get stiffer over time (2-3 years) and occasionally start squeaking against pulley flanges.
Check if front cover is rattling.	If so, check .125 in ID by .062 in thick O rings on dowel pins in base plate under front cover for any deterioration and replace if necessary.
Replace slip ring in c10 if present.	For units with 23 N electric replace the slip ring every third inspection test, or 20,000 hours of operation.

Appendix F: Safety Circuits for the c8A and c10 Robots

NOTE: Note: (2 kg robot has redundant E-stop and 48 V power supply enabled)

	Safety Circuit	Startup Test 1	Redundant	Continuous Test	Diagnostic Coverage	MTTFdl, Years	Power Off On Failure	PL	Category Safety
1	Estop	Yes	Yes	Yes	99%	100	Yes	d	4

- Startup test forces E-stop, checks 48 V power disable, zero amp current.
- Dual E-stop circuits turn off amp enable and PWM.
- Dual E-stop circuits turn off 48 V power.
- Stopping robot with hand turns off amp enable, PWM, and 48 V.

	Safety Circuit	Startup Test 1	Redundant	Continuous Test	Diagnostic Coverage	MTTFdl, Years	Power Off On Failure	PL	Category Safety
2	Encoder Feedback	Yes	No	Yes	90%	59	Yes	d	4

- Startup test checks encoder communication, prevents mtr power if fault.
- Serial update at 8 kHz w checksum, comm check, accel check.
- Counter embedded in position word to confirm CPU read from FPGA,

	Safety Circuit	Startup Test 1	Redundant	Continuous Test	Diagnostic Coverage	MTTFdl, Years	Power Off On Failure	PL	Category Safety
3	CPU Monitor	Yes	Yes	Yes	99%	100	Yes	d	4

- Startup test forces CPU WD low, checks 48 V power disabled.
- Independent dual watchdog timers turn off amp enable, PWM and 48 V.
- Processor on safety board monitors main CPU. Disables 48 V if failure.

	Safety Circuit	Startup Test 1	Redundant	Continuous Test	Diagnostic Coverage	MTTFdl, Years	Power Off On Failure	PL	Category Safety
4	Position Envelope Error	Yes	Yes	Yes	90%	59	Yes	d	4

- Startup test checks encoder communication, prevents mtr power if fault.
- Serial update at 8 kHz w checksum, comm check, accel check.
- SW watchdog in servo loop turns off amp enable, PWM and 48 V.
- Counter embedded in position word to confirm CPU read from FPGA.

	Safety Circuit	Startup Test 1	Redundant	Continuous Test	Diagnostic Coverage	MTTFdl, Years	Power Off On Failure	PL	Category Safety
5	Power amp Fault	Yes	Yes	Yes	90%	100	Yes	d	4

- Startup test confirms zero current when motor power enabled (phase offset test).
- Excess current to ground or phase to phase triggers shutdown in 10 sec.
- Saturated PID current command triggers shutdown in .050 sec.
- Shorted transistor just locks up brushless motor.

	Safety Circuit	Start up Test 1	Redundant	Continuous Test	Diagnostic Coverage	MTTFdl, Years	Power Off On Failure	PL	Category Safety
6	Collab Force Limit	Yes	Yes	Yes	90%	SW	Yes	d	4

- Tests 2, 3, 4, 5 above test HW.
- Position envelope error triggers fault, turns off power at amp and 48 V.
- Current saturation triggers separate fault, turns off power at amp and 48 V.
- Monitor function with WD turns off power at amp and 48 V.
- Monitor and CPU WD tested at startup turning off 48 V.
- Asymmetric current limits limit Z force even with gravity load.

Appendix G: System Diagram and Power Supplies

The robot has a 24 VDC and 48 VDC power supply located in the Z column. The power supplies have both over-current and over-voltage protection and are CSA, UL, and CE certified. The robot controller and electric gripper are powered by the 24 VDC supply. The main robot motors are powered by the 48 VDC supply. The 48 VDC supply is protected against over voltage bus pump up by an energy dump circuit, which connects a 75-Watt dump resistor located in the base housing across the 48 VDC supply output when the voltage reaches 56 Volts, and disconnects the dump resistor when the voltage drops to 52 Volts. This protects the power supply during high speed motor deceleration when the motor generates Back EMF voltage that adds to the power supply voltage.

DC power is routed from the power supplies to the controllers through a ribbon cable which also contains three twisted pairs for RS-485 (one pair) and 100 BaseT Ethernet (two pairs).

Twelve digital input and eight digital output signals from the main robot controller are available in the 25-pin Dsub on the connector panel in the base. The twelve digital output signals can be individually configured as either sourcing or sinking by software settings in the web interface. The eight digital input signals can be configured as either sourcing or sinking individually and the twelve digital inputs can be configured as sourcing or sinking in blocks of four by software settings in the web interface. See the section on IO.

It is necessary to wire an Emergency Stop Button to the controller. This button may be wired in series with other emergency stop contacts. The E-Stop signals are available in the Manual Control Pendant 9-pin DSub connector that is mounted on the Facilities Panel. See the Hardware Reference section of this manual for detailed information on the E-Stop signals. The robot is shipped with a jumper that completes the dual E-Stop circuits.

The cable from the brake release button under the shoulder plugs into the amplifier board for the Z-axis motor on the back of the Z column. This button provides a ground return from the Z column brake to ground bypassing the transistor that performs this function under computer power so that the brake can be released manually without motor power being enabled, as long as 24 VDC is turned on. Care should be taken to support the links of the robot when this button is pushed as the links weigh 14 kg and will drop under gravity when this button is pushed.

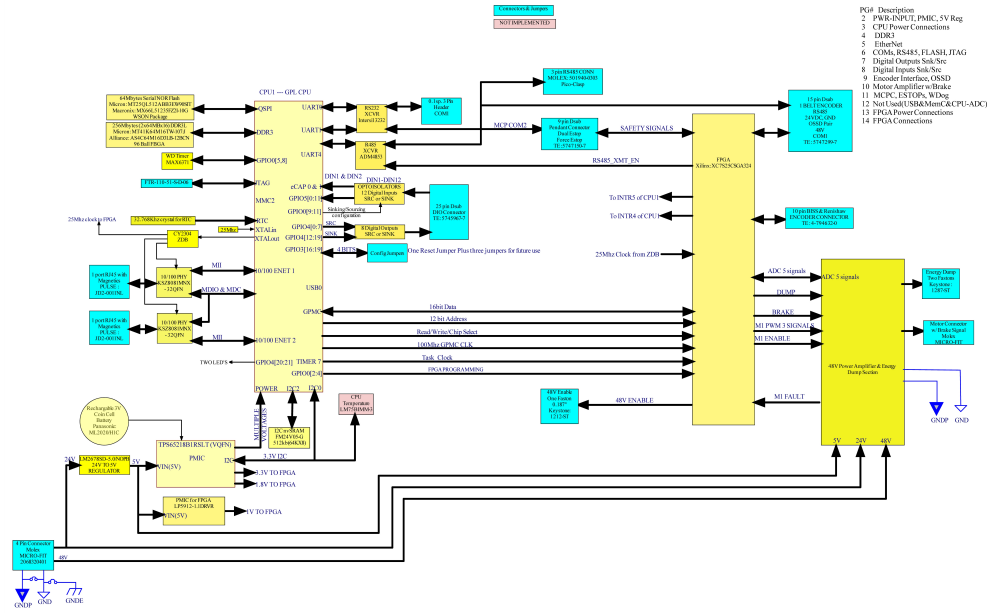

PFD0X - Block Diagram - P/N 890242

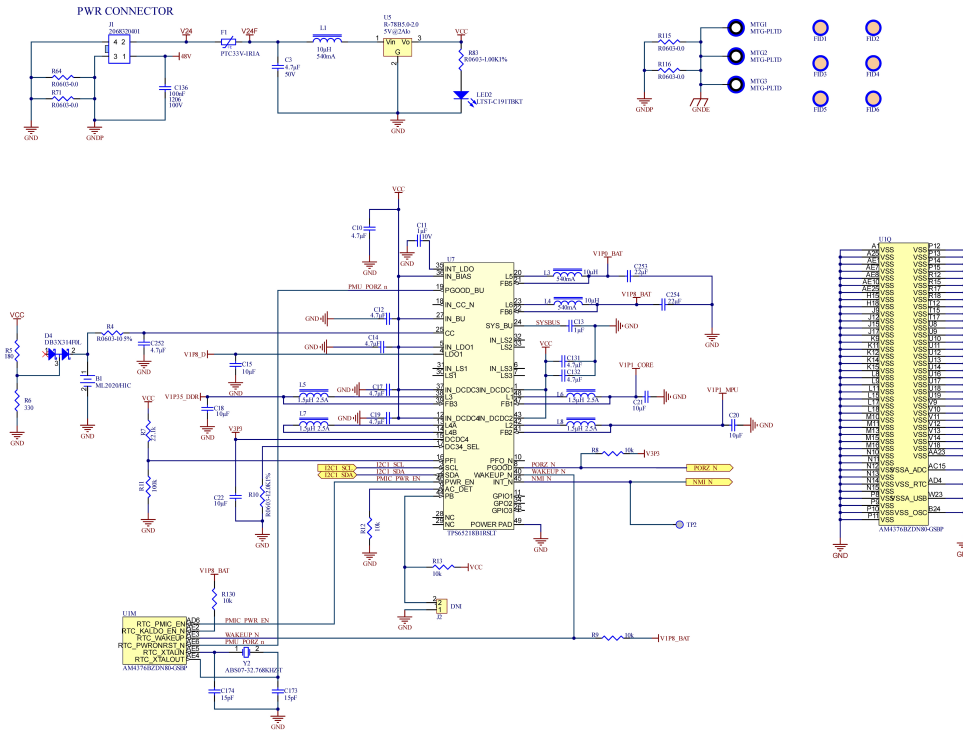

Joint Axis Controller Connectors - P/N 890242-00X

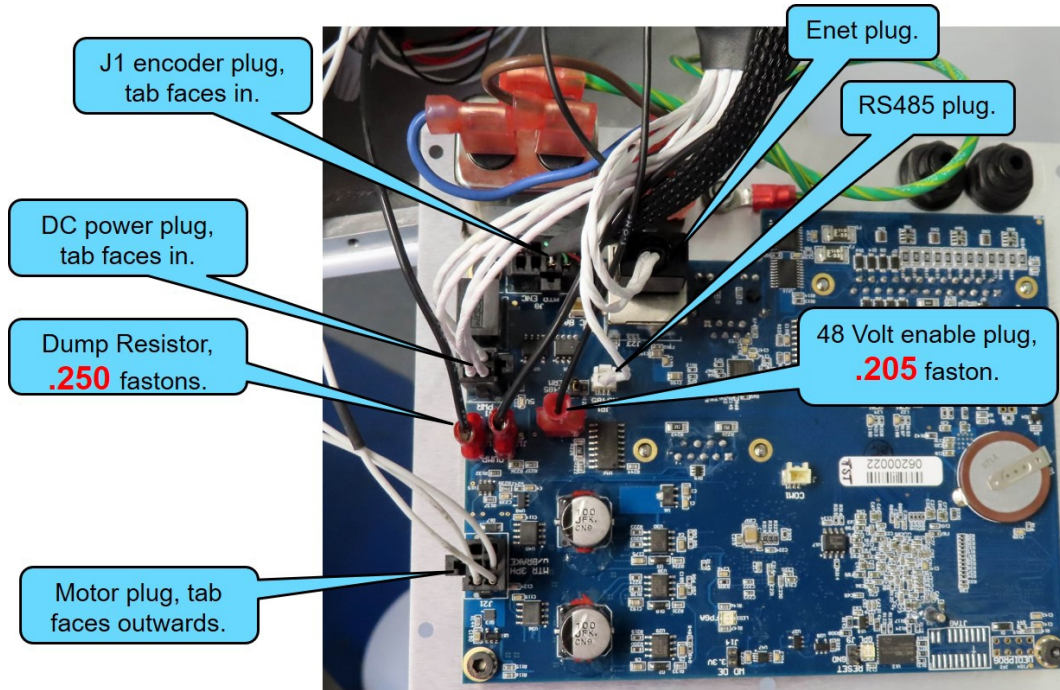

Base Controller Connectors

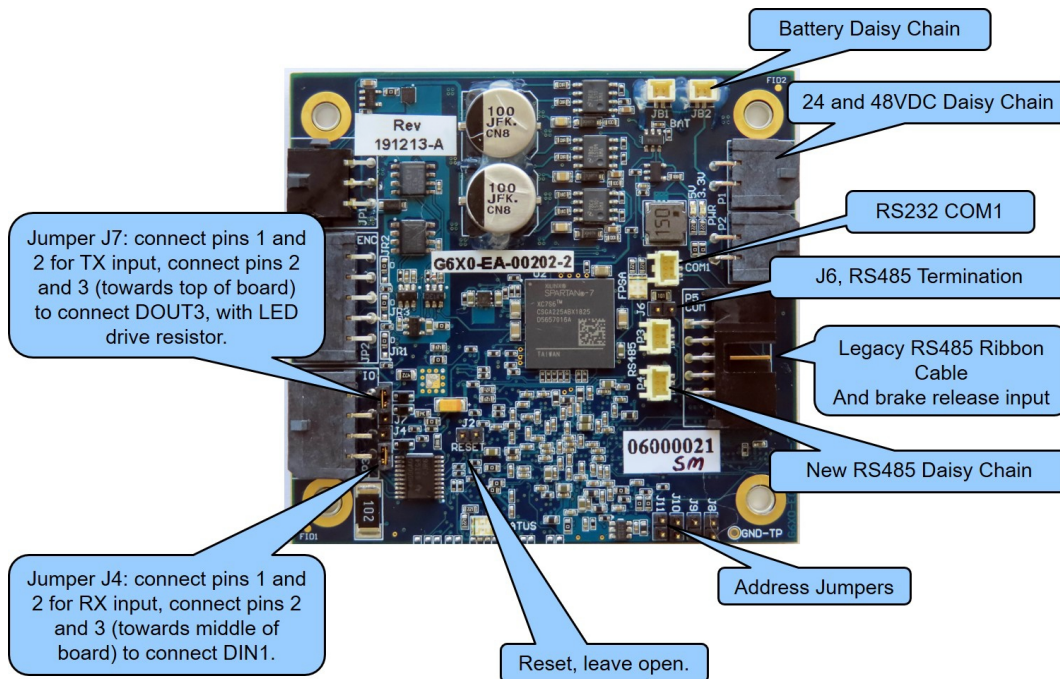

Gripper and Joint Axis Controller Connectors

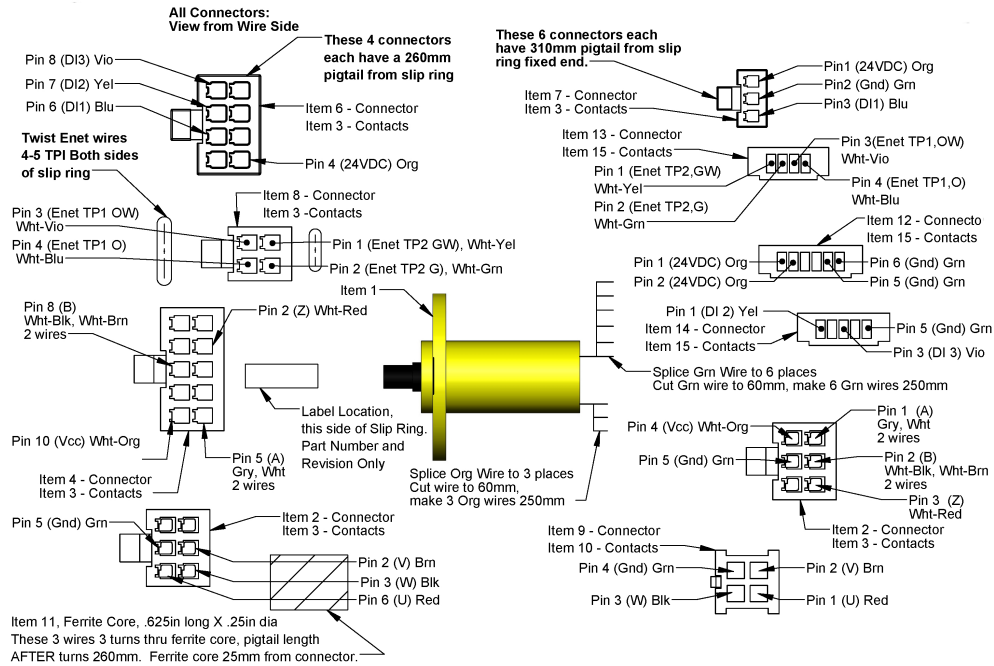

Slip Ring for 23 N Gripper, Ass., Harness with Sensor, Vision PFC - P/N 627468

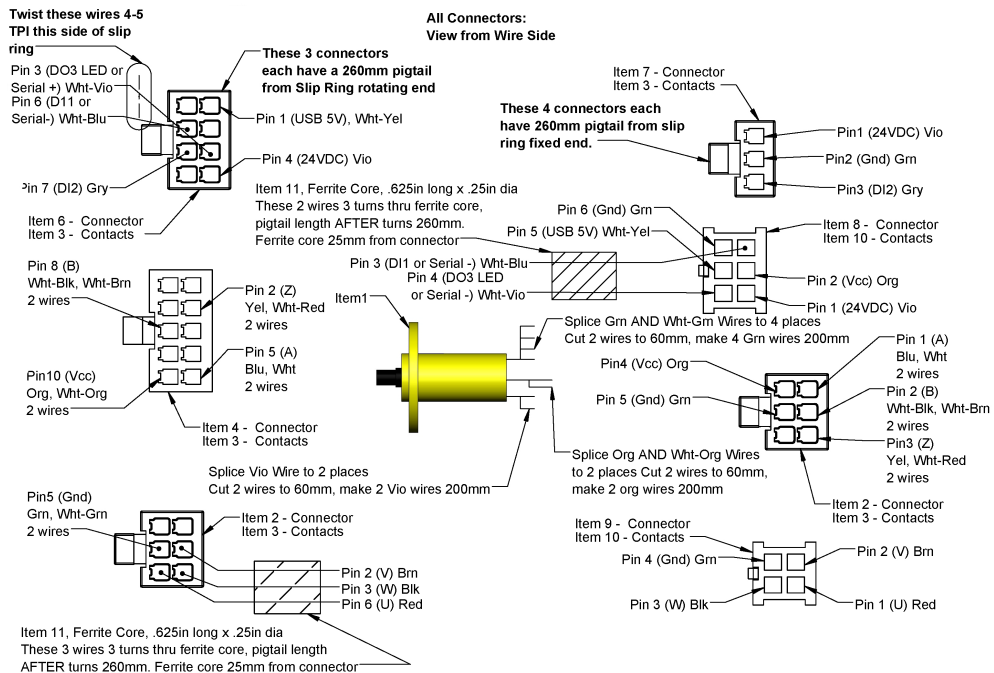

Slip Ring Dual and Single for 23 N Gripper, Ass., PFC

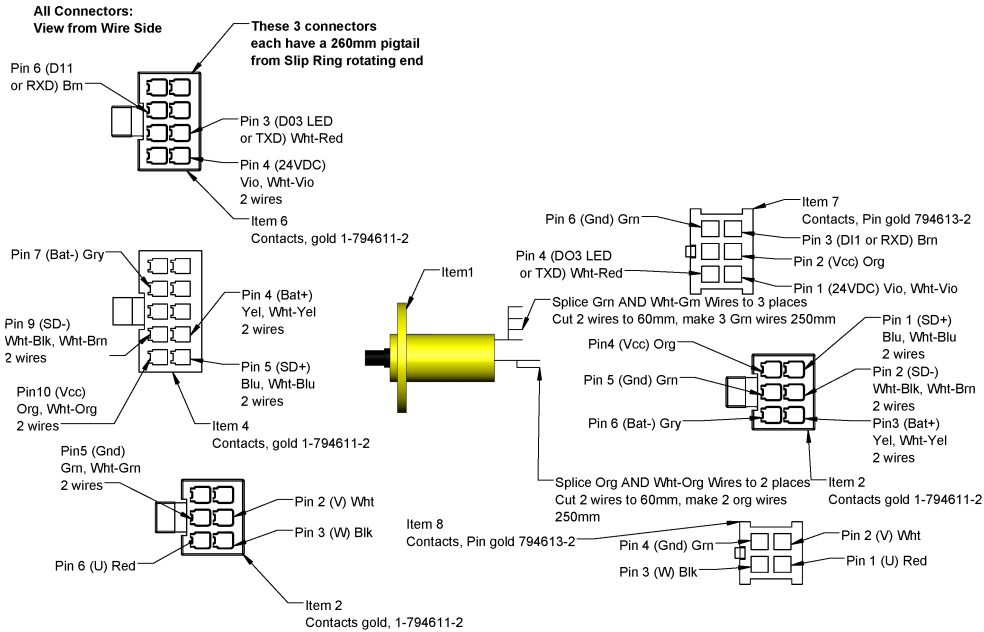

Slip Ring for 60 N Gripper, Ass., PFC

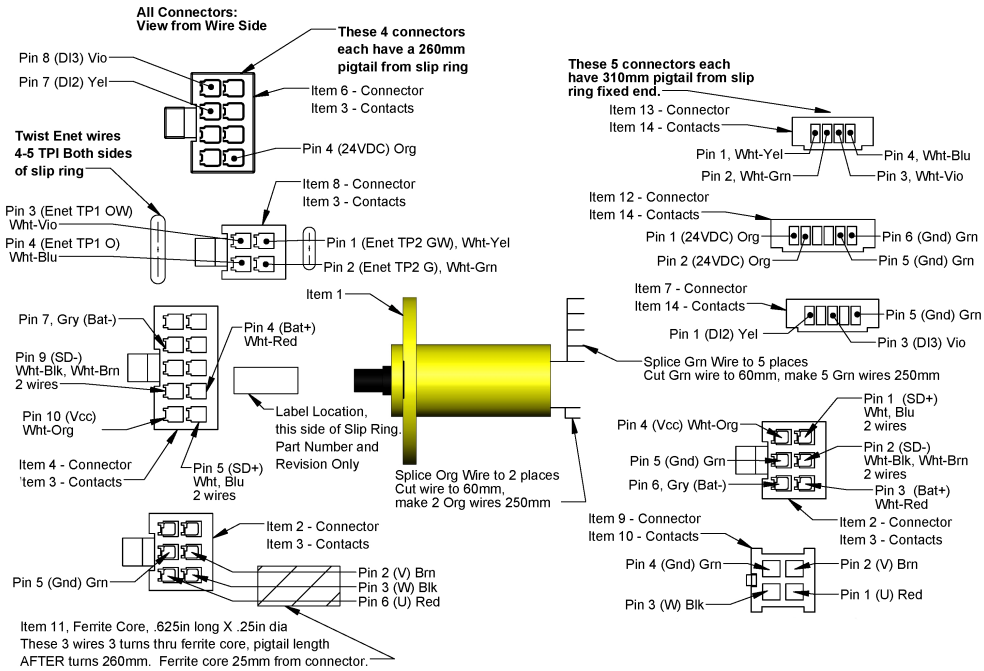

Slip Ring for 60 N Gripper, Ass., Vision, PFC - P/N 627235

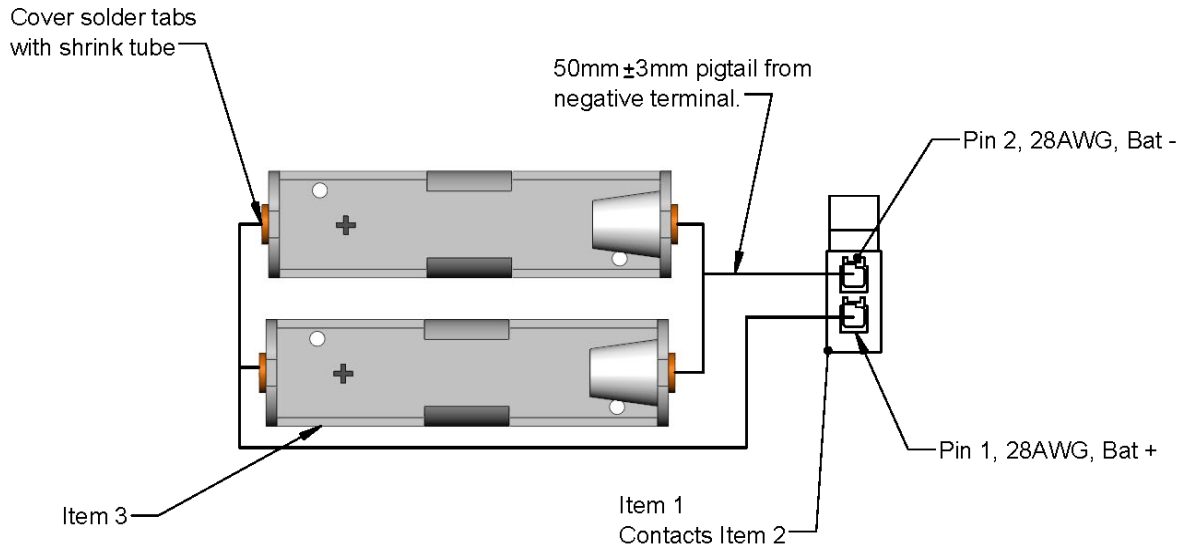

Assy, Cable, Dual Battery

View from Wire Side

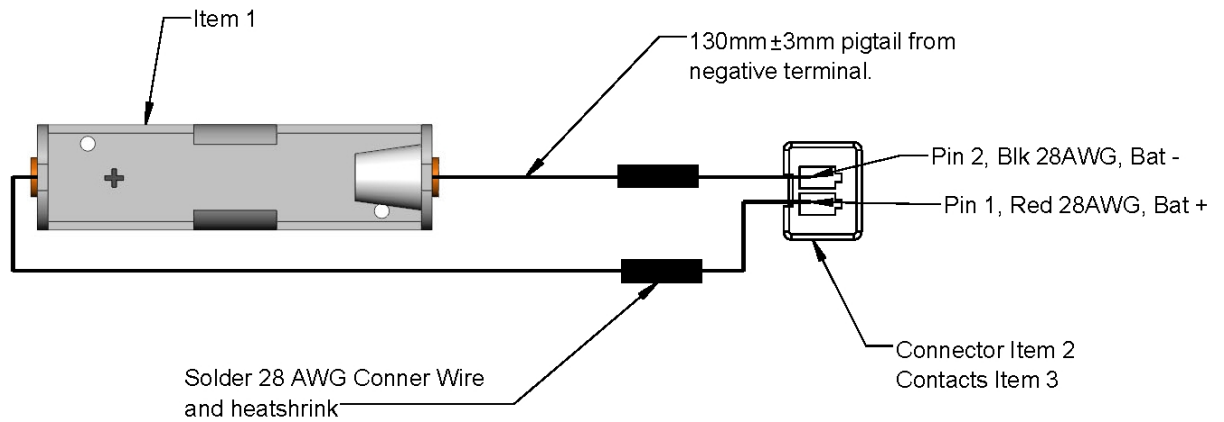

Assy, Cable, Single Battery

View from Wire Side

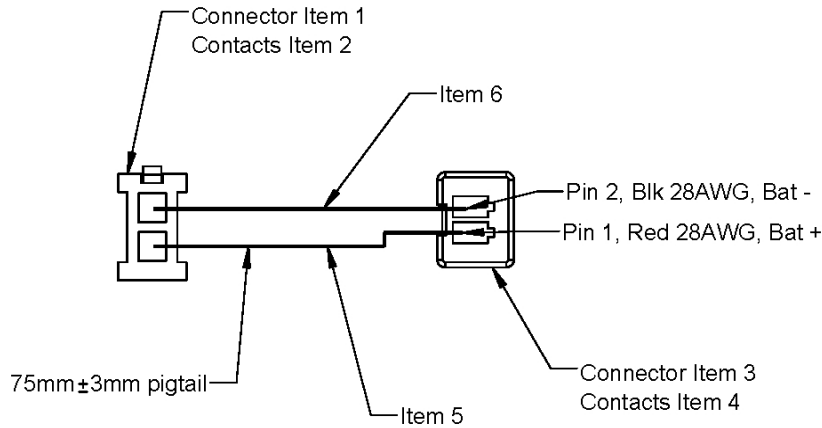

Assy, Cable, Battery Jumper

**View Wire Side
Grn/wht TP min 3 turns per inch**

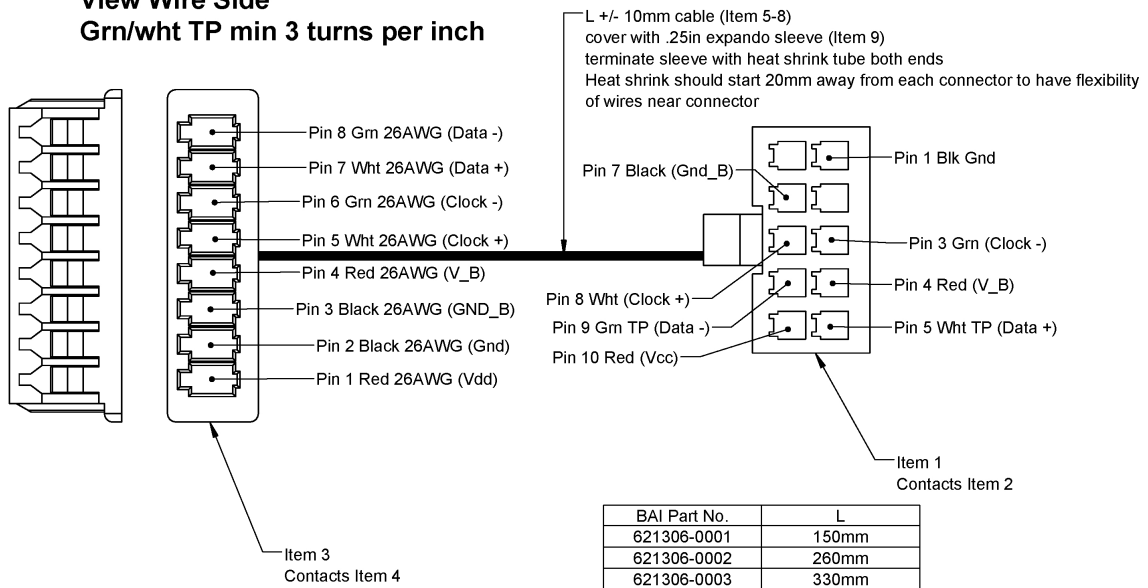

J1 Timken Encoder, PFD0X - P/N 621306

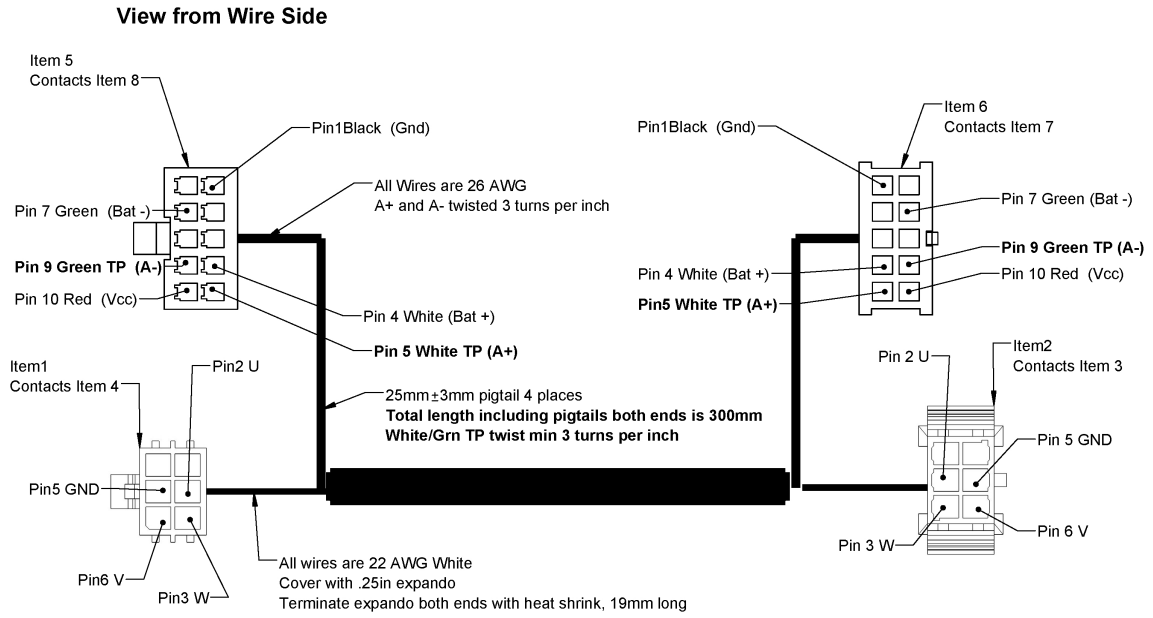

Motor and Encoder Pigtails, J6 PFDO - P/N 621472

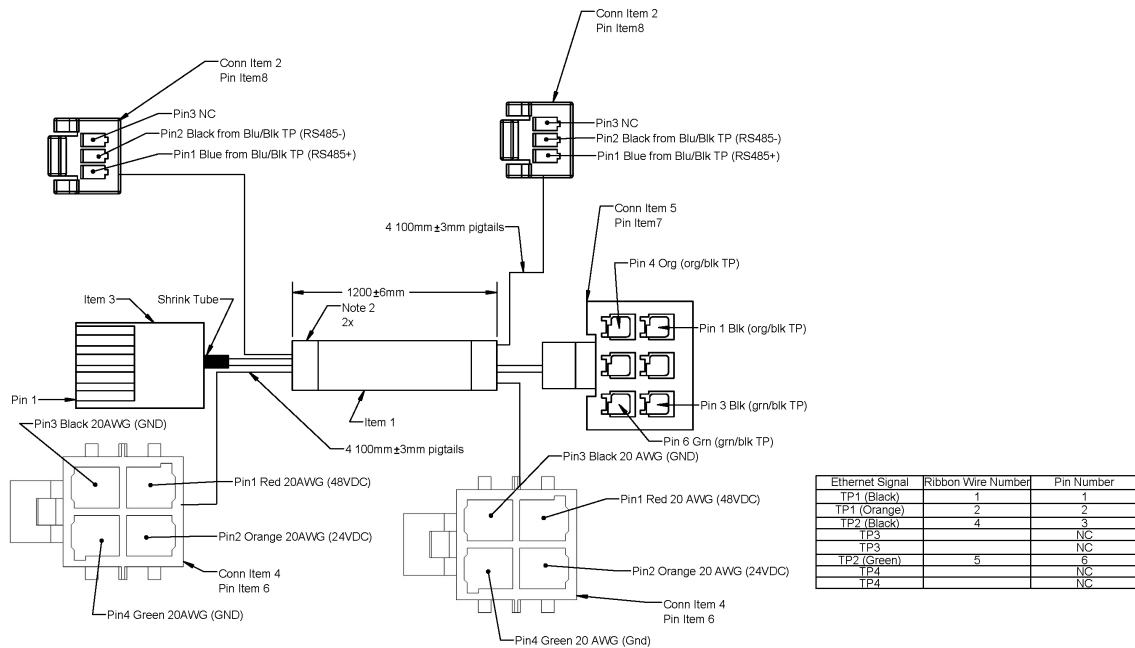

Harness, Signal and DC Power, Base, PFDO - P/N 621475

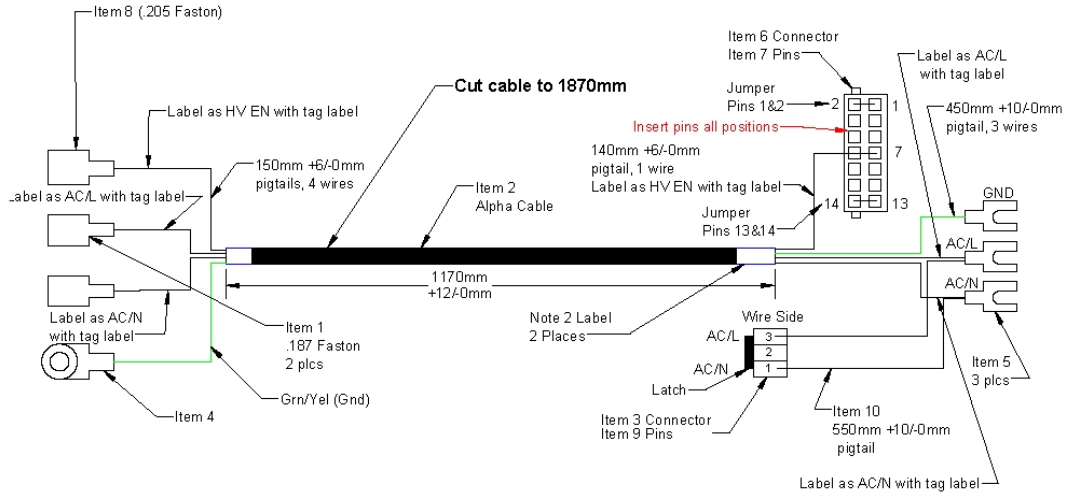

Harness, AC Power, PFDO - 00030

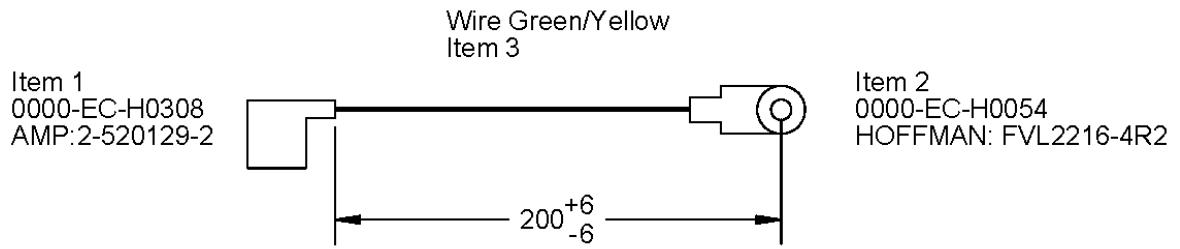

Harness, AC Power, PFDO - 00031

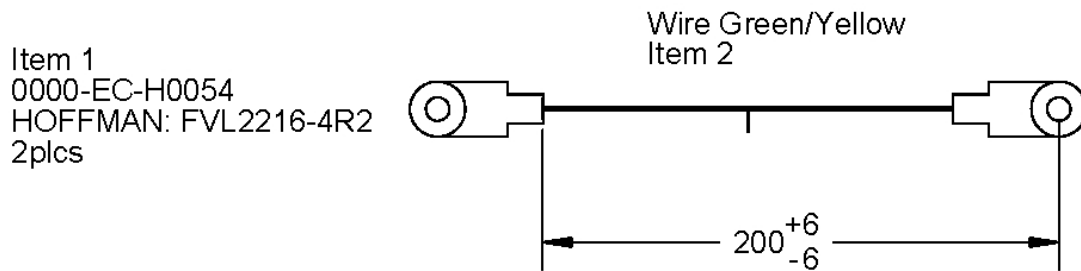

Harness, AC Power, PFDO - 00032

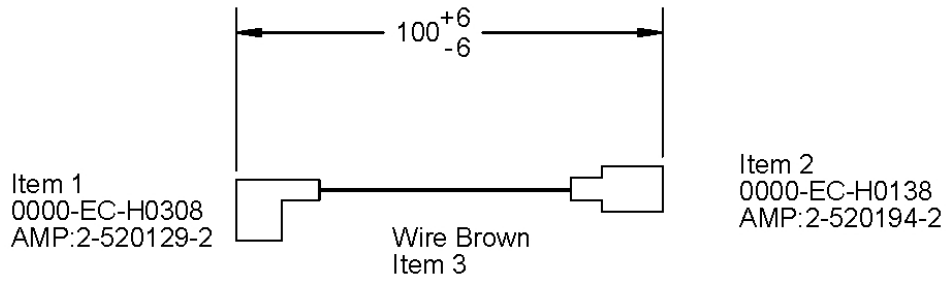

Harness, AC Power, PFDO - 00041

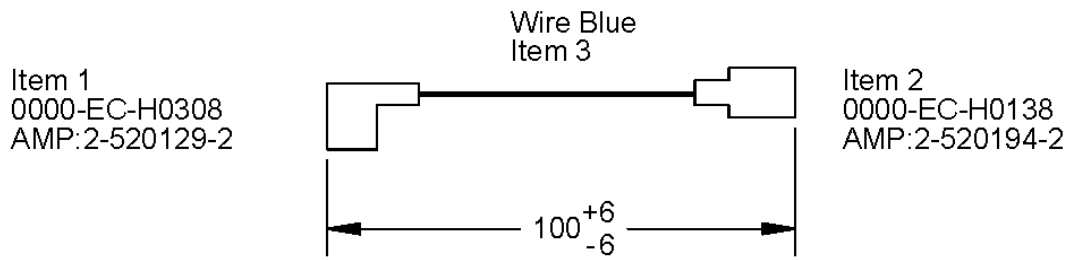

Harness, AC Power, PFDO - 00042

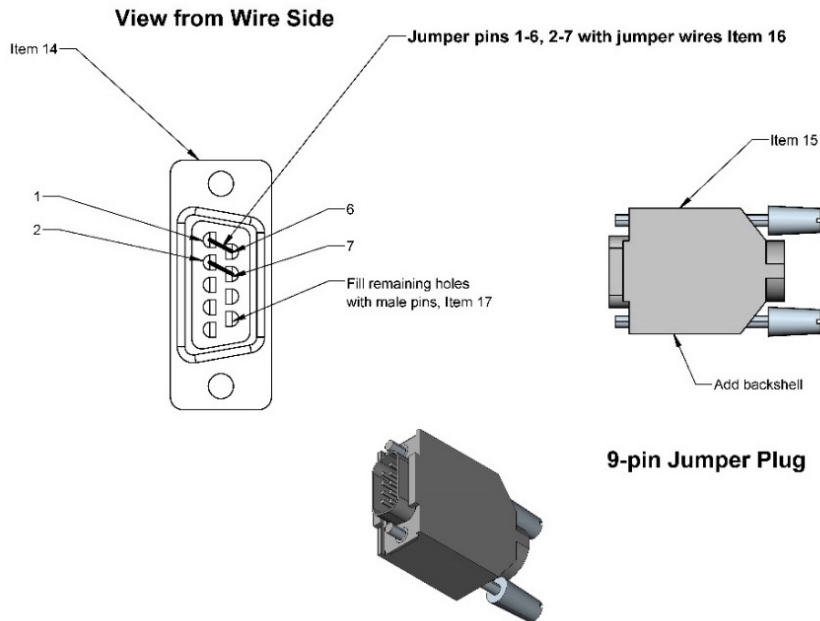

Harness, AC Power, PFDO

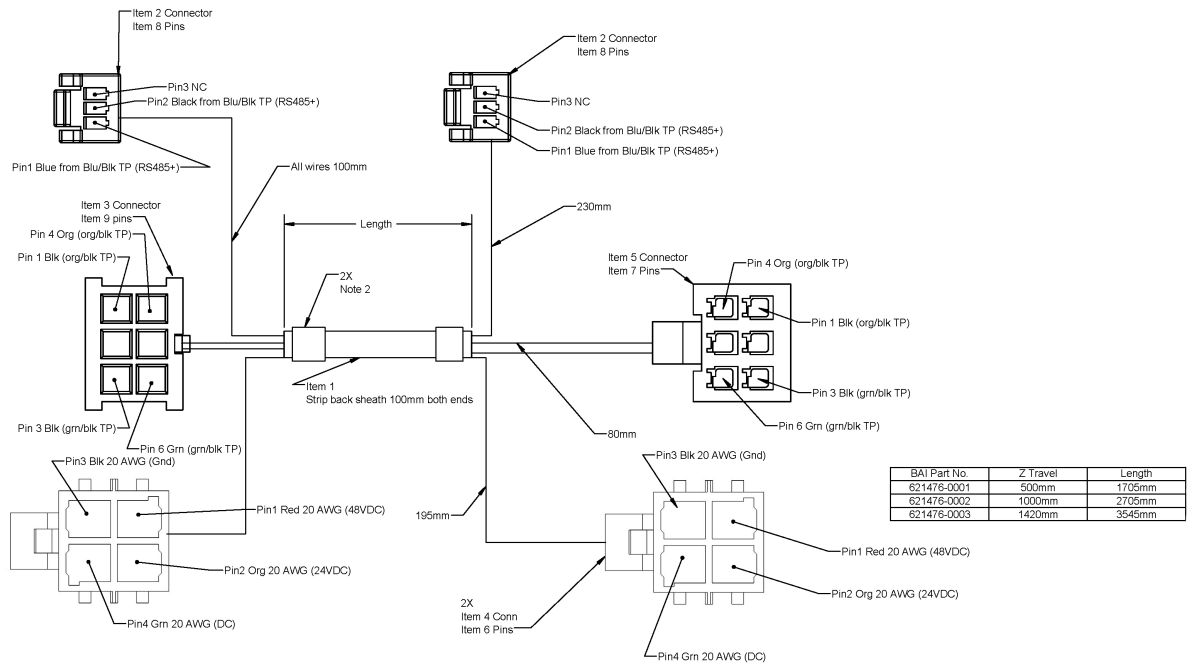

Harness, Column and Inner Link, PFDO P/N 621476

**View Wire Side
Grn/wht TP min 3 turns per inch**

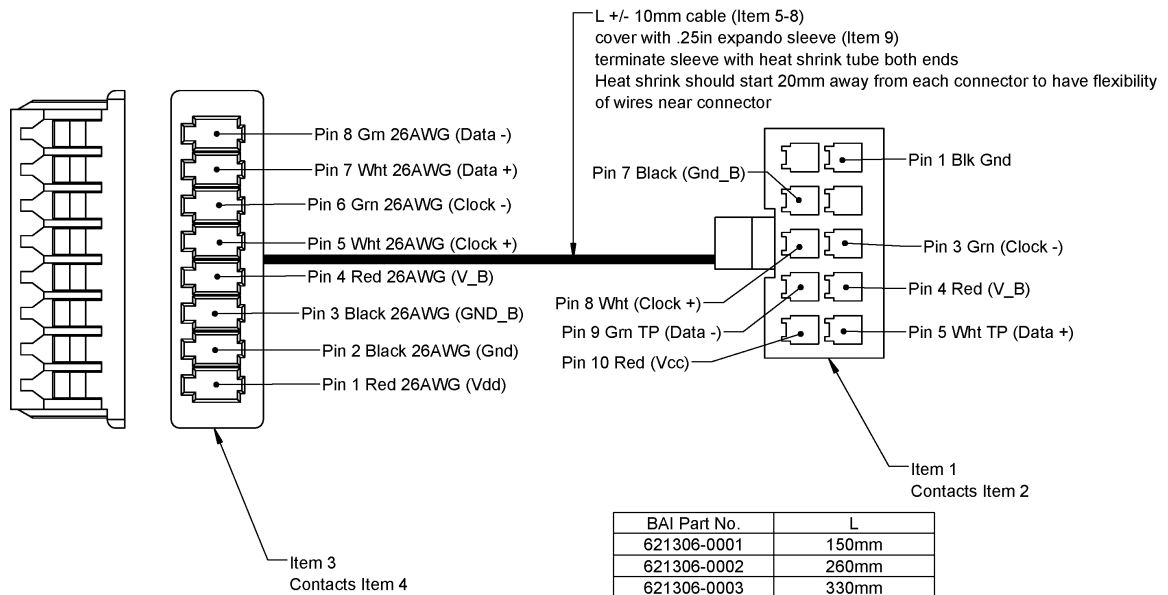

J3 Timken Encoder, PFDOX - P/N 621306-0001

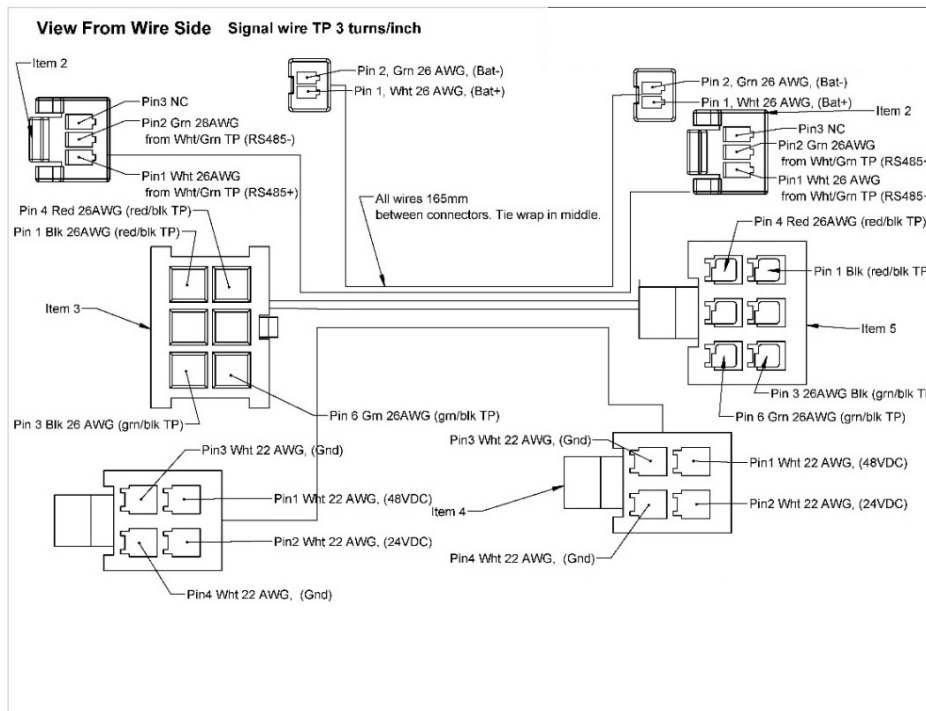
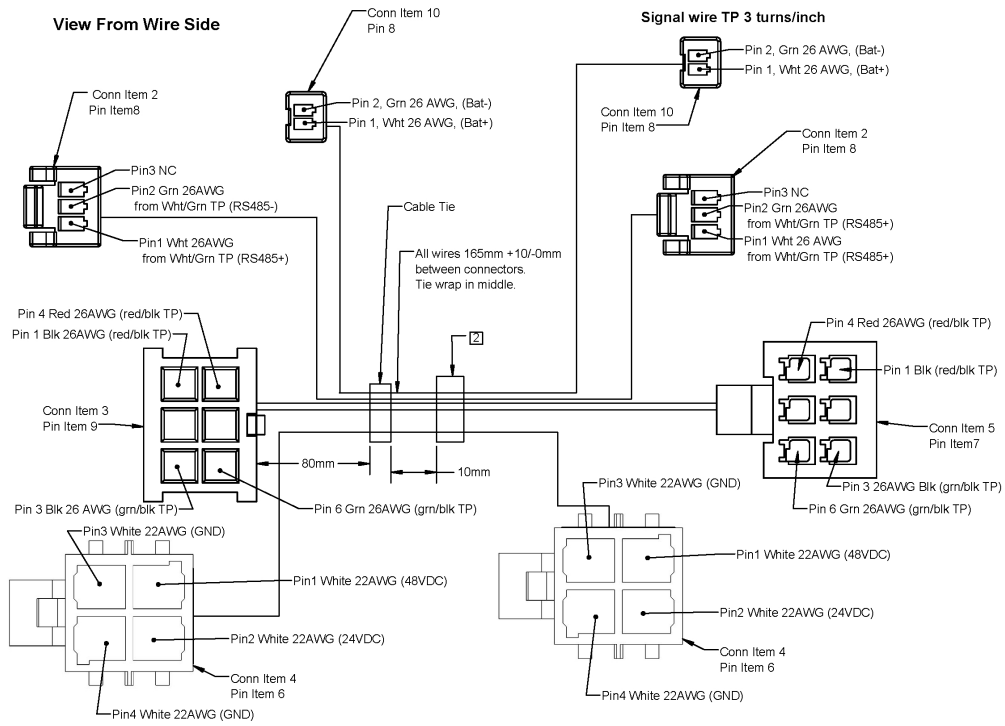

Harness, J5 to J6, PFDO - P/N 622724

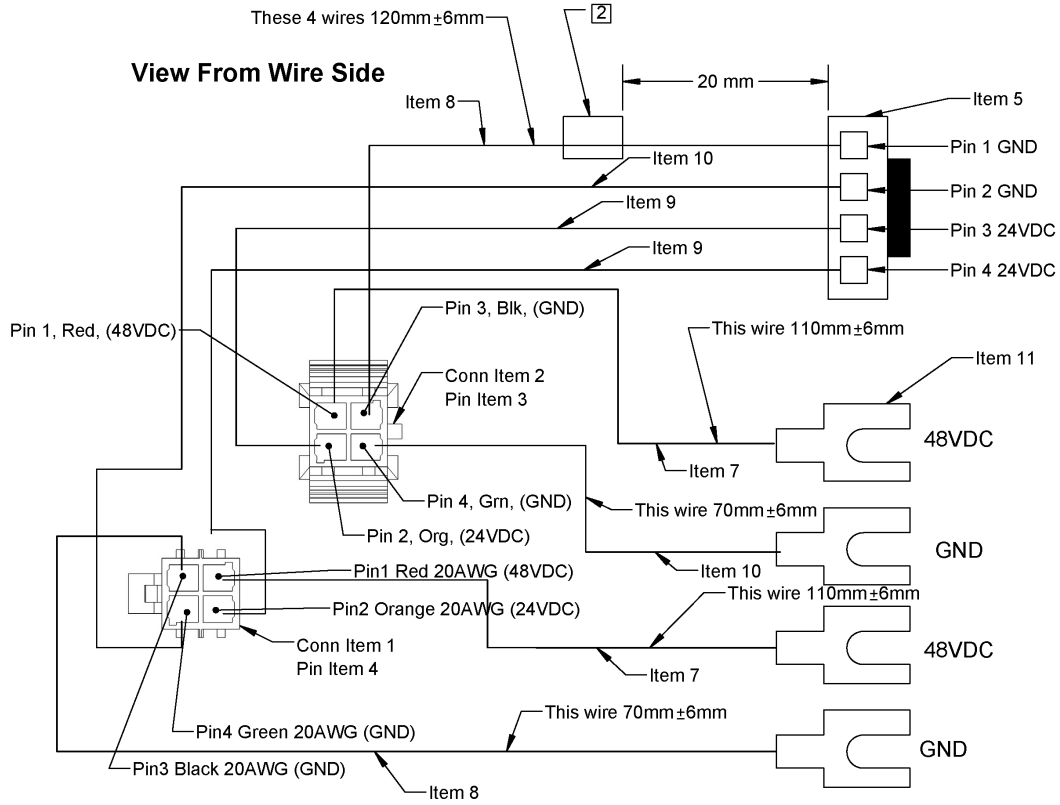

Harness, DC Interconnect, PFDO - P/N 622725

Total Cable Length is 1290mm

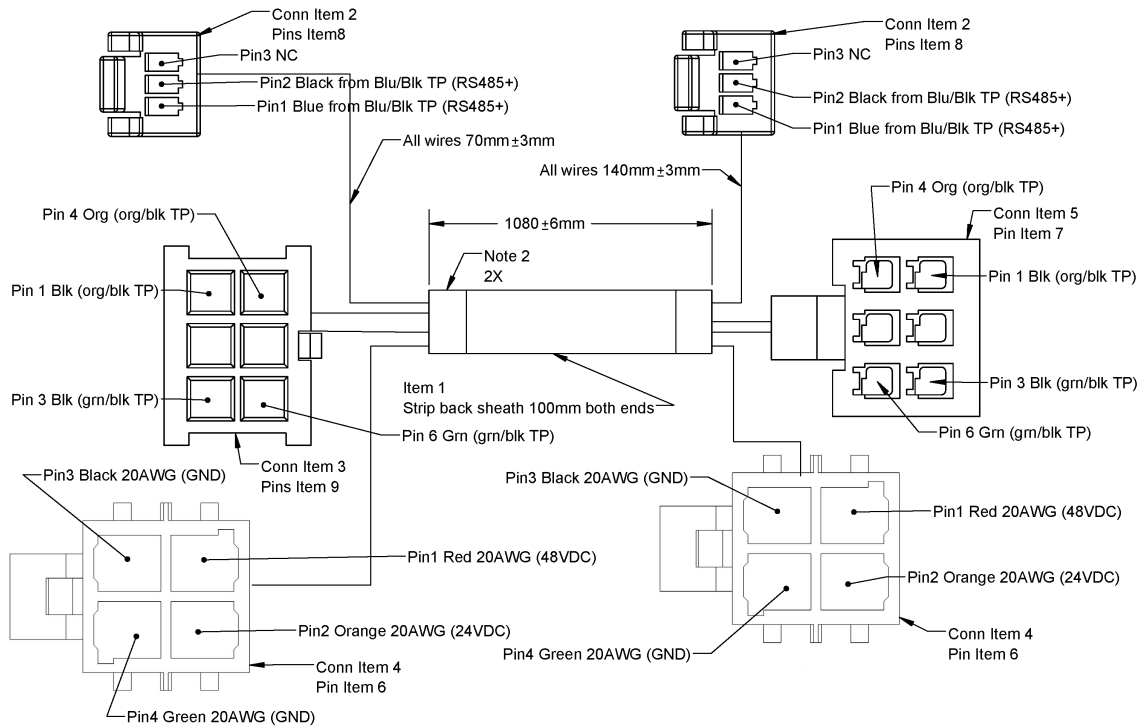

Harness, J3 Clockspring, PFDO - P/N 622726

View: Wire Side

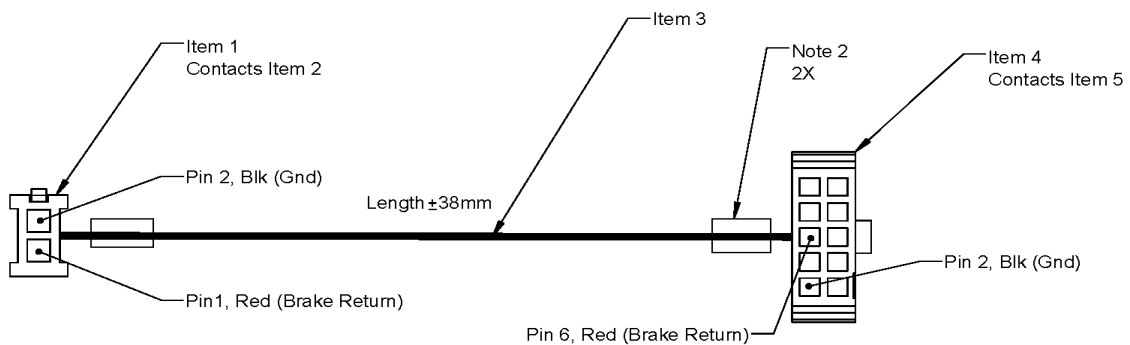

BAI Part No.	Z Travel	Length
389630-0001	500mm	1600mm
389630-0002	1000mm	2600mm
389630-0003	1420mm	3440mm

Harness, Brake Release Cable Extension, PFDO - P/N 389630

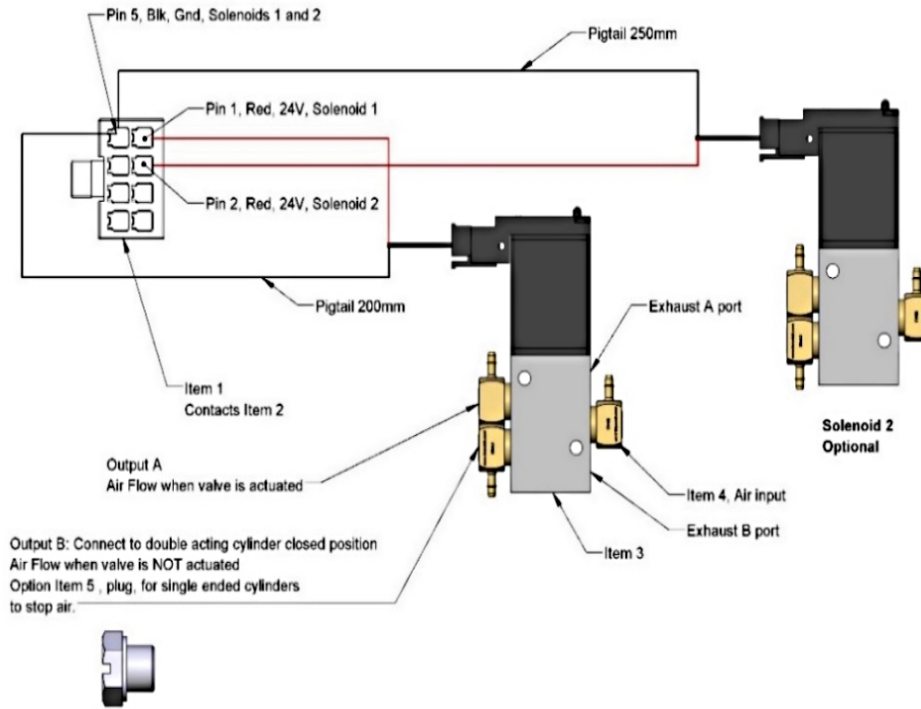

Harness, Single and Dual Valve, PFDO

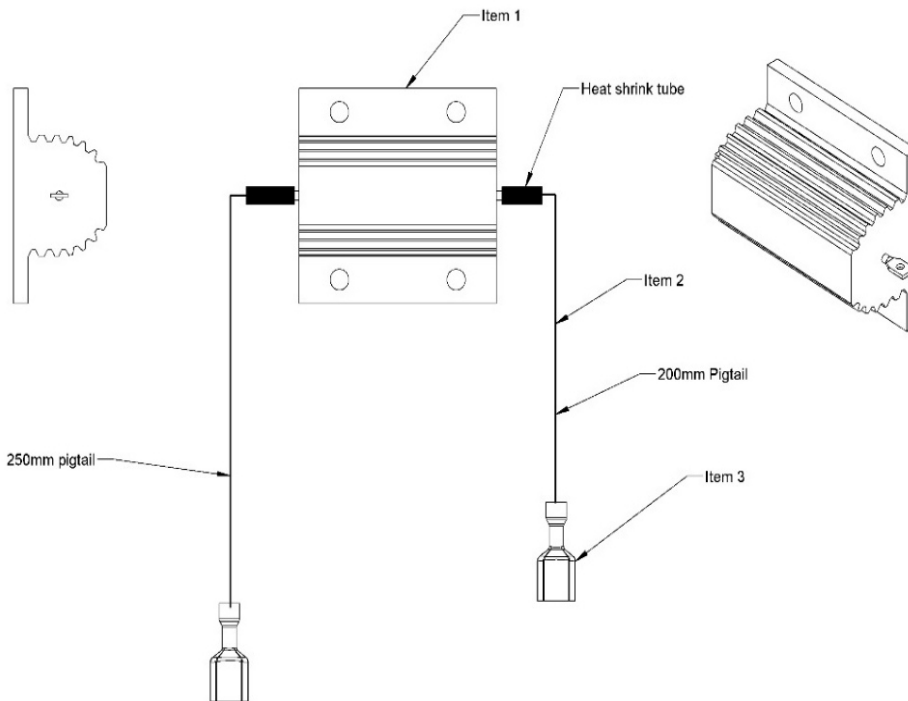

Harness, Dump Resistor with Pigtail, PFDO

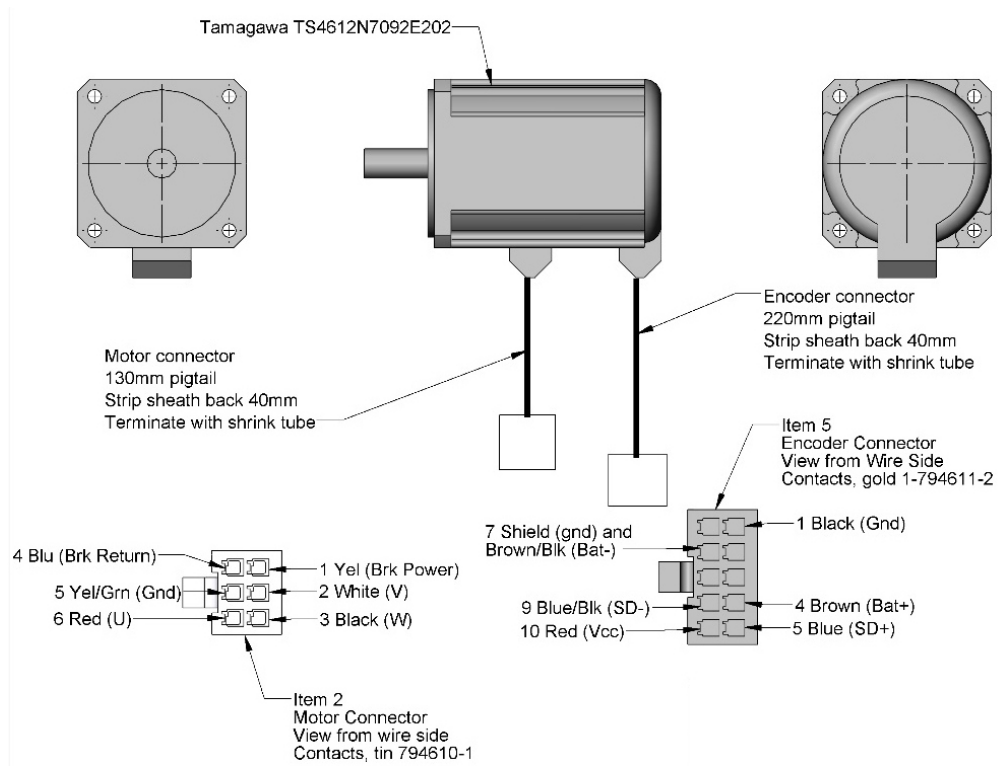

J2 Motor with Pigtail

Appendix H: Control System Overview

The PreciseFlex c8A and PreciseFlex c10 Robots are controlled by a distributed control system (see examples below). The main control board (PFD0) is located in the base casting behind the connector panel. This board contains various IO functions, the main CPU, RAM, and Flash memory, and the motor drive for the J1 motor. The 24 VDC and 48 VDC power supplies are located on the back of the Z column. A flexible ribbon cable is routed around the robot to provide 24 VDC, Gnd, 48 VDC, Gnd, Ethernet, and RS485. Ethernet is routed to the outer link and is available for certain gripper applications. A series of smart amplifiers (GSBP) are distributed around the robot and located near each motor to minimize wiring through the robot. These are connected by means of an RS485 network.

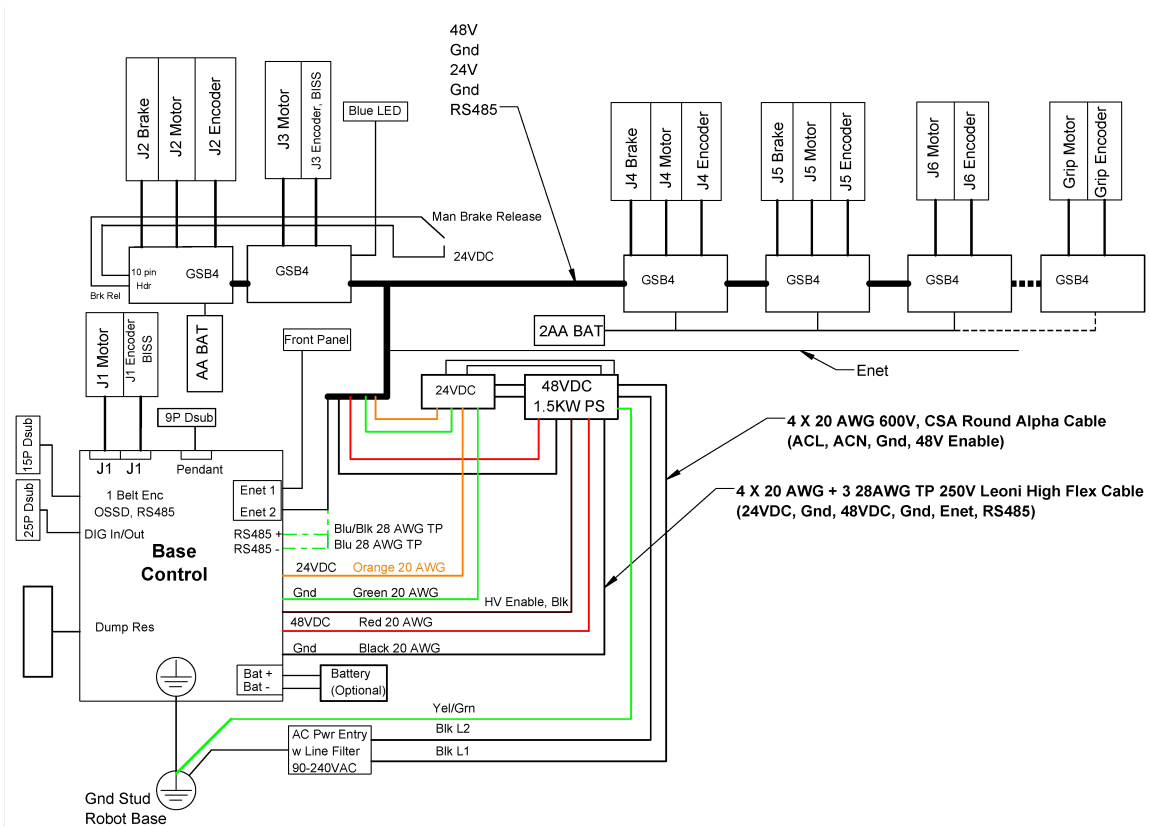

PreciseFlex c8A Control System

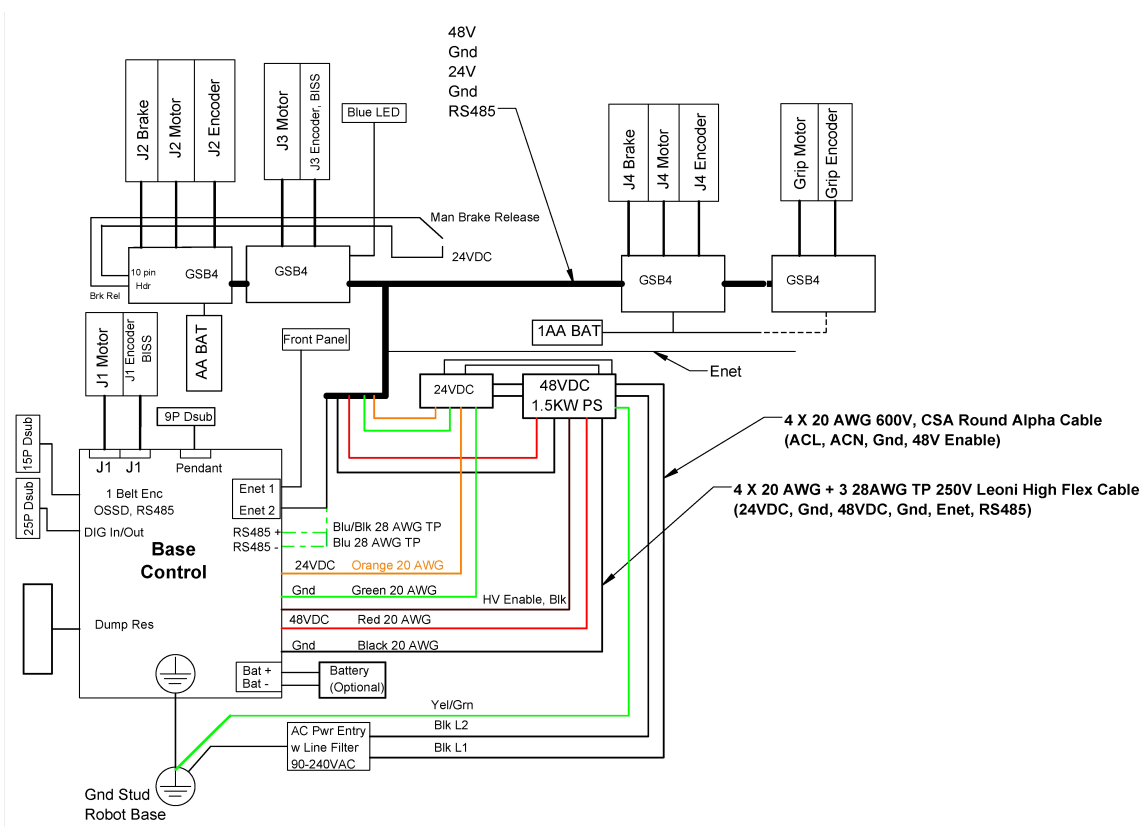

c10 Control System

Appendix I: Belt Tensions, Gates Tension Meter

In some cases, it may be desirable to confirm the belt tension of one of the axes in the robot. If it appears a belt tension is not correct, the tension can be checked with a Gates Sonic Tension Meter, Model 507C or 508C.



To use the tension meter, follow the procedure below.

Step	Action
1.	Turn on the power.
2.	Click Mass and enter the belt mass from the table below.
3.	Click Width and enter the belt width from the table below.
4.	Click Span and enter the belt free span from the table below.
5.	Click Select to record the data.
6.	Click Measure to take a tension reading.
7.	Place the microphone near the belt, typically within 3 mm or so. Gently pluck the belt so that it vibrates. The tension meter will calculate the belt tension from the acoustic vibrations and display the tension in Newtons. Compare the tension to the table below. Adjust the belt tension preload screws if necessary.

Belt Tensions

Axis	Mass (g)	Width (mm)	Span (mm)	Tension (N)
Z-Axis S1	4.1	12	120	70 - 90
Z-Axis S2 - 500	4.8	14	620	400 - 420
Z-Axis S2 - 1000	4.8	14	1120	400 - 420
Z-Axis S2 - 1420	4.8	14	1540	400 - 420
J5	2.8	9	146	45 - 60

Appendix J: Example Performance Level Evaluation

Example Workcell description: A c10 moves 100-gram plastic trays from storage racks to an instrument and back to the storage racks. The gripper is an electric parallel jaw gripper with maximum 23 N of gripping force for plastic trays and is spring loaded so it will not drop trays if power fails. Robot motion is programmed with approach point 50 mm above the instrument tray and final motion into the instrument is made at 50 mm/sec. Lowest storage rack position is 50 mm above the table surface.



Example workcell, courtesy of Biosero

Normal Operator Interaction with Robot:

Teaching locations in workcell by hand guiding or teach pendant. Maximum robot forces under manual control are 105 N. Pausing robot and removing racks from workcell with safety interlocks in workspace. Robot is stopped.

Possible Low Frequency (rare) Interaction with Robot:

Untrained operator reaches into workcell while robot is moving and robot collides with operator. Maximum free space collision force is 182 N, which is below free space collision for 500 ms maximum of 280 N. Untrained operator reaches into workcell while robot is moving into instrument tray and hand is trapped between robot and instrument tray. Max trapping force in downwards Z direction at 60 mm/sec (10% of max speed of 600 mm/sec) is 77 N.

Performance Level: From the above, based on [ISO 13849-1:2006](#):

- S is S1, as possible operator collision forces will not injure operators.
- F is F1 as normal operation does not involve collisions with robot.
- P is P1 as the robot does not make unexpected motions

So PL is “a,” and even a Category B controller is sufficient given the low speeds and small possible collisions forces involved which cannot injure an operator. (See 5.2.3 under [EN/ISO 10218-1:2011](#)).

Appendix K: Table A2 from ISO/TS 15066: 2016

NOTE: All results in this appendix are from testing on the PreciseFlex DD4 robot.

Biomechanical Force and Pressure Limits

Biomechanical limits

Body region	Specific body area		Quasi-static contact		Transient contact	
			Maximum permissible pressure ^a P_s N/cm ²	Maximum permissible force ^b N	Maximum permissible pressure multiplier ^c P_T	Maximum permissible force multiplier ^c F_T
<i>Skull and forehead^d</i>	1	<i>Middle of forehead</i>	130	130	not applicable	not applicable
	2	<i>Temple</i>	110		not applicable	
<i>Face^d</i>	3	<i>Masticatory muscle</i>	110	65	not applicable	not applicable
Neck	4	Neck muscle	140	150	2	2
	5	Seventh neck muscle	210		2	
Back and shoulders	6	Shoulder joint	160	210	2	2
	7	Fifth lumbar vertebra	210		2	
Chest	8	Sternum	120	140	2	2
	9	Pectoral muscle	170		2	
Abdomen	10	Abdominal muscle	140	110	2	2
Pelvis	11	Pelvic bone	210	180	2	2
Upper arms and elbow joints	12	Deltoid muscle	190	150	2	2
	13	Humerus	220		2	
Lower arms and wrist joints	14	Radial bone	190	160	2	2
	15	Forearm muscle	180		2	
	16	Arm nerve	180		2	

^a These biomechanical values are the result of the study conducted by the University of Mainz on pain onset levels. Although this research was performed using state-of-the-art testing techniques, the values shown here are the result of a single study in a subject area that has not been the basis of extensive research. There is anticipation that additional studies will be conducted in the future that could result in modification of these values. Testing was conducted using 100 healthy adult test subjects on 29 specific body areas, and for each of the body areas, pressure and force limits for quasi-static contact were established evaluating onset of pain thresholds. The maximum permissible pressure values shown here represent the 75th percentile of the range of recorded values for a specific body area. They are defined as the physical quantity corresponding to when pressures applied to the specific body area create a sensation corresponding to the onset of pain. Peak pressures are based on averages with a resolution size of 1 mm². The study results are based on a test apparatus using a flat (1.4 × 1.4) cm (metal) test surface with 2 mm radius on all four edges. There is a possibility that another test apparatus could yield different results. For more details of the study, see Reference [5].

^b The values for maximum permissible force have been derived from a study carried out by an independent organization (see Reference [6]), referring to 188 sources. These values refer only to the body regions, not to the more specific areas. The maximum permissible force is based on the lowest energy transfer criteria that could result in a minor injury, such as a bruise, equivalent to a severity of 1 on the Abbreviated Injury Scale (AIS) established by the Association for the Advancement of Automotive Medicine. Adherence to the limits will prevent the occurrence of skin or soft tissue penetrations that are accompanied by bloody wounds, fractures or other skeletal damage and to be below AIS 1. They will be replaced in future by values from a research more specific for collaborative robots.

^c The multiplier value for transient contact has been derived based on studies which show that transient limit values can be at least twice as great as quasi-static values for force and pressure. For study details, see References [2], [3], [4] and [7].

^d Critical zone (*italicized*)

Table A.2 (continued)

Body region	Specific body area		Quasi-static contact		Transient contact	
			Maximum permissible pressure ^a p_s N/cm ²	Maximum permissible force ^b N	Maximum permissible pressure multiplier ^c P_T	Maximum permissible force multiplier ^c F_T
Hands and fingers	17	Forefinger pad D	300	140	2	2
	18	Forefinger pad ND	270		2	
	19	Forefinger end joint D	280		2	
	20	Forefinger end joint ND	220		2	
	21	Thenar eminence	200		2	
	22	Palm D	260		2	
	23	Palm ND	260		2	
	24	Back of the hand D	200		2	
	25	Back of the hand ND	190		2	
Thighs and knees	26	Thigh muscle	250	220	2	2
	27	Kneecap	220		2	
Lower legs	28	Middle of shin	220	130	2	2
	29	Calf muscle	210		2	

^a These biomechanical values are the result of the study conducted by the University of Mainz on pain onset levels. Although this research was performed using state-of-the-art testing techniques, the values shown here are the result of a single study in a subject area that has not been the basis of extensive research. There is anticipation that additional studies will be conducted in the future that could result in modification of these values. Testing was conducted using 100 healthy adult test subjects on 29 specific body areas, and for each of the body areas, pressure and force limits for quasi-static contact were established evaluating onset of pain thresholds. The maximum permissible pressure values shown here represent the 75th percentile of the range of recorded values for a specific body area. They are defined as the physical quantity corresponding to when pressures applied to the specific body area create a sensation corresponding to the onset of pain. Peak pressures are based on averages with a resolution size of 1 mm². The study results are based on a test apparatus using a flat (1,4 × 1,4) cm (metal) test surface with 2 mm radius on all four edges. There is a possibility that another test apparatus could yield different results. For more details of the study, see Reference [5].

^b The values for maximum permissible force have been derived from a study carried out by an independent organization (see Reference [6]), referring to 188 sources. These values refer only to the body regions, not to the more specific areas. The maximum permissible force is based on the lowest energy transfer criteria that could result in a minor injury, such as a bruise, equivalent to a severity of 1 on the Abbreviated Injury Scale (AIS) established by the Association for the Advancement of Automotive Medicine. Adherence to the limits will prevent the occurrence of skin or soft tissue penetrations that are accompanied by bloody wounds, fractures or other skeletal damage and to be below AIS 1. They will be replaced in future by values from a research more specific for collaborative robots.

^c The multiplier value for transient contact has been derived based on studies which show that transient limit values can be at least twice as great as quasi-static values for force and pressure. For study details, see References [2], [3], [4] and [7].

^d Critical zone (*italicized*)

Appendix L: c10 - Test Methods for Measuring Forces and Pressures in Human-Robot Contact

Testing in this report is based on the publicly available specification [ISO/PAS 5672:2023 Robotics — Collaborative applications — Test methods for measuring forces and pressures in human-robot contacts](#). This document is modeled on the Reporting Template of that ISO specification, Annex E.

Application

This Pick and place application includes a robot shown in the figure below. The robot's task is to pick up workpieces from the conveyor and transfer them to a target station.

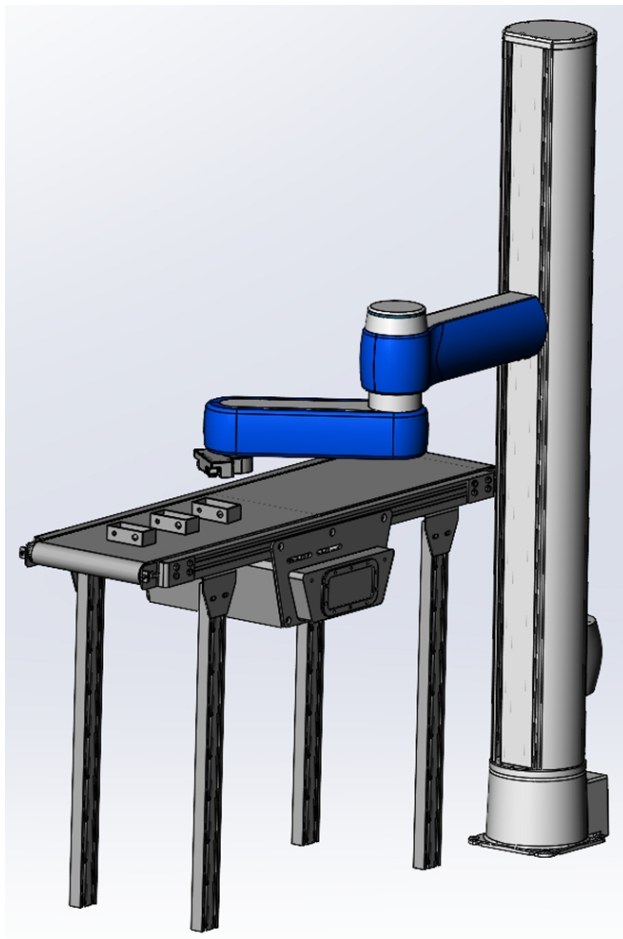

Contact Hazards and Measuring Points: Contact Hazard 1

Pinch of the Hand When Robot Approaches Workpiece on the Station

If a misaligned workpiece on the station is about to disturb the process, a human operator can try to correct the position of the workpiece by hand as the robot approaches it. This event of foreseeable misuse can lead to unintended contact with human. Since the robot approaches the workpiece slowly and the station constitutes an obstacle that hinders movement of the human body, the type of contact constitutes a pinch (load profile = quasi-static; spatial config = constrained).

Body regions that can be affected by the impact are lower arms and wrist joints and hands and fingers. Measurement method is a force sensor.

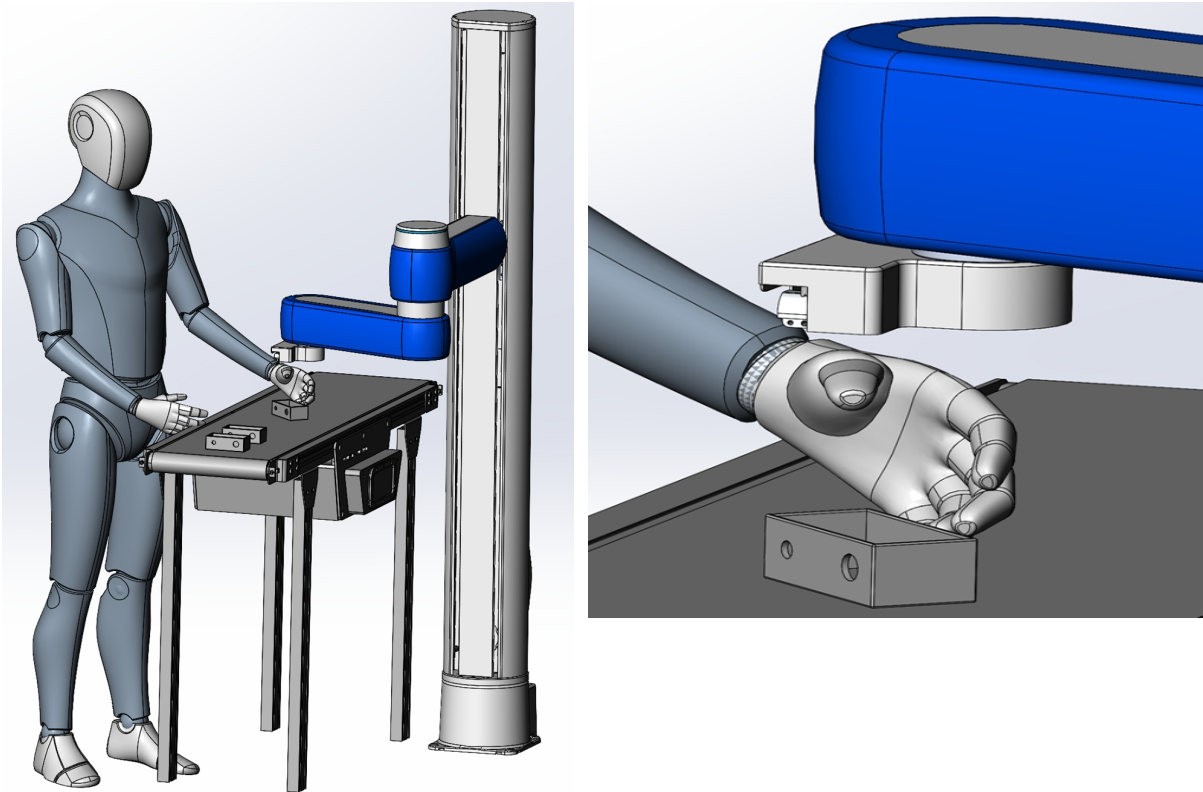



Possibly Endangered Body Locations

ID	Body Location	Force [N]		Contact type		
		QS	TR	Pinch	Impact	Crush
1	Lower arms and wrist joints	160 N	N /A	X	N/A	N/A
2	Hands and fingers	140 N	N/A	X	N/A	N/A

Measurement Results from Test of Body Location ID (1,2) – Height Detection Enabled. This method is done at the application level.

Speed	Auto adjusted by Z-Height detect functionality
Payload	4 kg
Notes	Default settings / Z-Height detection enabled
Start position	Angles(0,1100,215,-40)

End position	Angles(0,1001.5,215,-40)
Impact Position	Angles(0,981.5,215,-40)
Distance after impact	20 mm
Motion profile	Auto adjusted by Z-Height detect functionality

Criteria 1 (quality indicator for the measurement setup; ISO/PAS 5672:2023, 7.4)

Contact Phase	Relative Standard Deviation For	~ [%]	Threshold	Measurement Setup
Quasi-static	Force [N]	N/A	5	N/A
	Pressure [N/cm ²]	N/A	10	N/A
Transient	Force [N]	2.178	5	OK
	Pressure [N/cm ²]	N/A	10	N/A

Criteria 2 (Comparison of Sample Mean with the Biomechanical Limit for the Body Location Tested; ISO/PAS 5672:2023, 7.4)

Contact phase	Mean for	Units Measured (N)	Limit	Test
Quasi-static	Force [N]	N/A	N/A	N/A
	Pressure [N/cm ²]	N/A	...	N/A
Transient	Force [N]	131.7	280/320	Passed
	Pressure [N/cm ²]	N/A	...	N/A

Measurement Results from Test of Body Location ID (1,2) – Adjusted Negative Output Limit

Speed	10% (60 mm/sec)
--------------	-----------------

Payload	4 kg
Notes	Adjusted negative output level for Z axis
Start Position	Angles (0,1100,215,-40)
End Position	Angles (0,1001.5,215,-40)
Impact Position	Angles (0,981.5,215,-40)
Distance After Impact	20 mm
Motion Profile	Accel/Decel: 100%/50% RampUp/RampDown: 0.15 InRange: 10 System Speed: 100%

Criteria 1 (Quality Indicator for the Measurement Setup; ISO/PAS 5672:2023, 7.4)

Contact Phase	Relative Standard Deviation for	~ [%]	Threshold	Measurement Setup
Quasi-static	Force [N]	0	5	OK
	Pressure [N/cm ²]	N/A	10	OK / not OK
Transient	Force [N]	N/A	5	OK / not OK
	Pressure [N/cm ²]	N/A	10	OK / not OK

Criteria 2 (Comparison of Sample Mean with the Biomechanical Limit for the Body Location Tested; ISO/PAS 5672:2023, 7.4)

Contact Phase	Mean for	Units Measured (N)	Limit	Test
Quasi-static	Force [N]	138	140/160	Passed
	Pressure [N/cm ²]	N/A	N/A	N/A
Transient	Force [N]	N/A	N/A	N/A
	Pressure [N/cm ²]	N/A	N/A	N/A

Contact Hazards and Measuring Points: Contact Hazard 2

Impact with Upper Body Extremity When Robot Approaches Station Where Operator Task is Being Performed

A robot or operator drops a workpiece at the assembly/inspection station. The operator tries to remove it while the robot approaches the station with another part, leading to unintended contact with the operator's shoulder, back, or upper arms. Since the human body can move freely (no obstacles near the station), the type of contact will constitute an impact (load profile = dynamic; special config = unconstrained).

Body locations that can be affected by the impact are back, shoulders, chest, upper arms, and elbow joints. The cell must be designed with a spatial configuration resulting in the human body being able to recoil at impact and being unconstrained. Robot lateral motion shall be at or below the shoulder level. Pinch and crush contact types are not considered for this contact hazard. Measurement method is a force sensor.

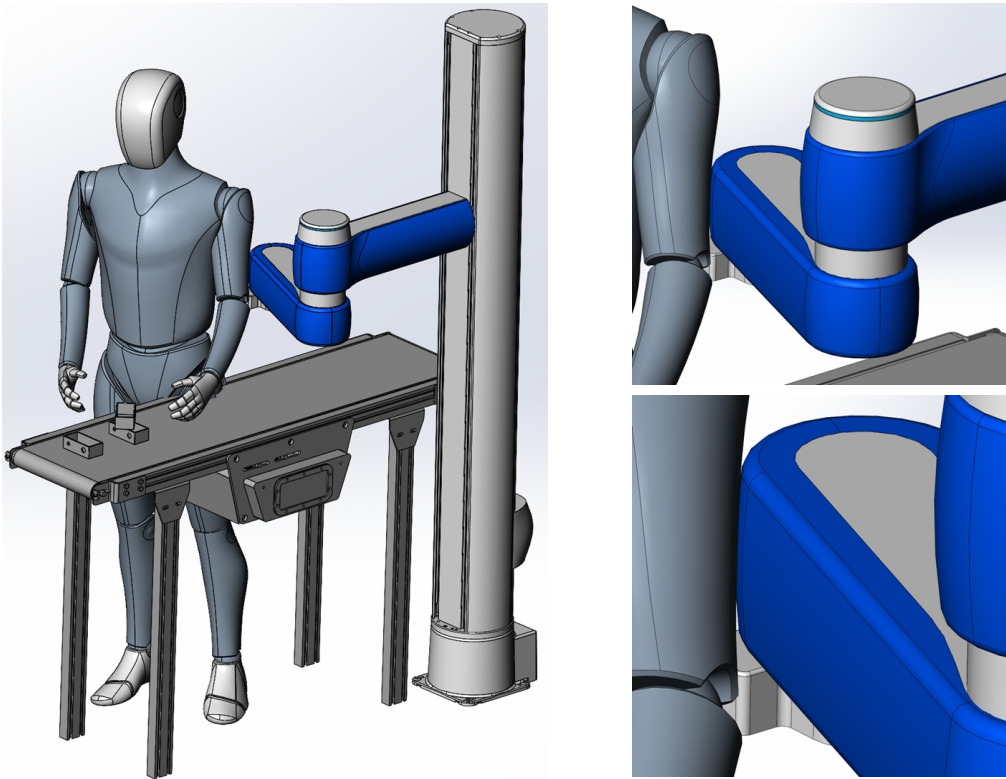

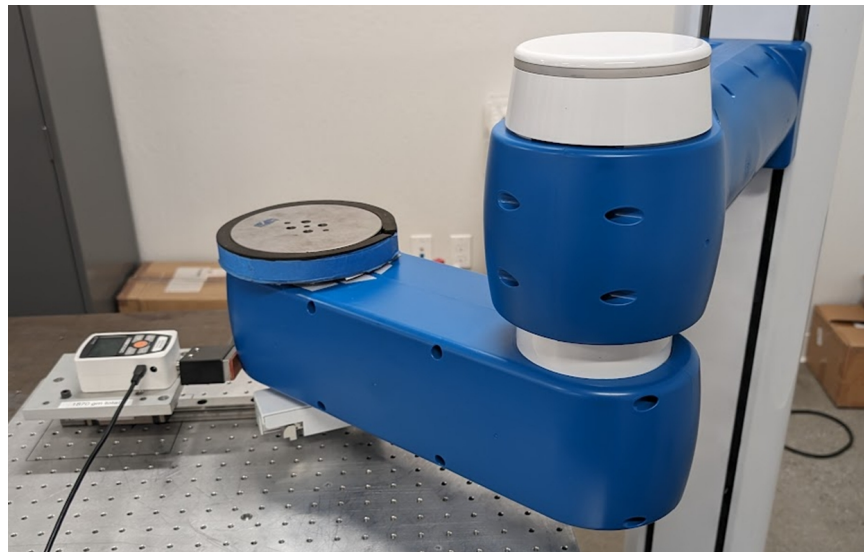

Possibly Endangered Body Locations

ID	Body Location	Force [N]		Contact Type		
		QS	TR	Pinch	Impact	Crush
1	Back & shoulder	N/A	$F_T = 210 \times 2$	N/A	X	N/A
2	Chest	N/A	$F_T = 140 \times 2$	N/A	X	N/A
3	Upper arms & elbow joints	N/A	$F_T = 150 \times 2$	N/A	X	N/A

Measurement Results from Test of Body Location ID (1,2,3) – X Axis Cartesian Motion.

Speed	100% (600 mm/sec)
Payload	4 kg
Notes	X Axis Cartesian motion / Default settings
Start position	XYZ(250,-250,855,5,90,-180)
End position	XYZ(680,-250,855,5,90,-180)
Impact Position	XYZ(730,-250,855,5,90,-180)

Distance after impact	50 mm
Motion profile	Accel/Decel: 100%/100% RampUp/RampDown: 0.15 InRange: 10 System Speed: 100%

Criteria 1 (Quality Indicator for the Measurement Setup; ISO/PAS 5672:2023, 7.4)

Contact phase	Relative standard deviation for	[%]	Threshold	Measurement Setup
Quasi-static	Force [N]	N/A	5	N/A
	Pressure [N/cm ²]	N/A	10	N/A
Transient	Force [N]	0.42	5	OK
	Pressure [N/cm ²]	N/A	10	N/A

Criteria 2 (Comparison of Sample Mean with the Biomechanical Limit for the Body Location Tested; ISO/PAS 5672:2023, 7.4)

Contact phase	Mean for	Units Measured (N)	Limit	Test
Quasi-static	Force [N]	N/A	N/A	N/A
	Pressure [N/cm ²]	N/A	...	N/A
Transient	Force [N]	113.33	280/300/420	Passed
	Pressure [N/cm ²]	N/A	...	N/A

Measurement Results from Test of Body Location ID (1,2,3) – Y Axis Cartesian Motion

Speed	100% (600 mm/sec)
Payload	4 kg
Notes	Y Axis Cartesian motion / Default settings

Start Position	XYZ (235,-150,950,-110,90,-180)
End Position	XYZ (235,-550,950,-110,90,-180)
Impact Position	XYZ (235,-600,950,-110,90,-180)
Distance after Impact	50 mm
Motion Profile	Accel/Decel: 100%/100% RampUp/RampDown: 0.15 InRange: 10 System Speed: 100%

Criteria 1 (Quality Indicator for the Measurement Setup; ISO/PAS 5672:2023, 7.4)

Contact Phase	Relative Standard Deviation for	[%]	Threshold	Measurement Setup
Quasi-Static	Force [N]	N/A	5	N/A
	Pressure [N/cm ²]	N/A	10	N/A
Transient	Force [N]	0.72	5	OK
	Pressure [N/cm ²]	N/A	10	N/A

Criteria 2 (Comparison of Sample Mean with the Biomechanical Limit for the Body Location Tested; ISO/PAS 5672:2023, 7.4)

Contact Phase	Mean for	Units Measured (N)	Limit	Test
Quasi-static	Force [N]	N/A	N/A	N/A
	Pressure [N/cm ²]	N/A	...	N/A
Transient	Force [N]	113	280/300/420	Passed
	Pressure [N/cm ²]	N/A	...	N/A

NOTE: Weight of the pressure-force measurement devices (PFMD) used for the impact force testing is 1.9 kg.

Appendix M: c8A - Test Methods for Measuring Forces and Pressures in Human-Robot Contact

Testing in this report is based on the publicly available specification [ISO/PAS 5672:2023 Robotics — Collaborative applications — Test methods for measuring forces and pressures in human-robot contacts](#). This document is modeled on the Reporting Template of that ISO specification, Annex E.

Application

This Pick and place application includes a robot shown in the figure below. The robot's task is to pick up workpieces from the conveyor and transfer them to a target station.

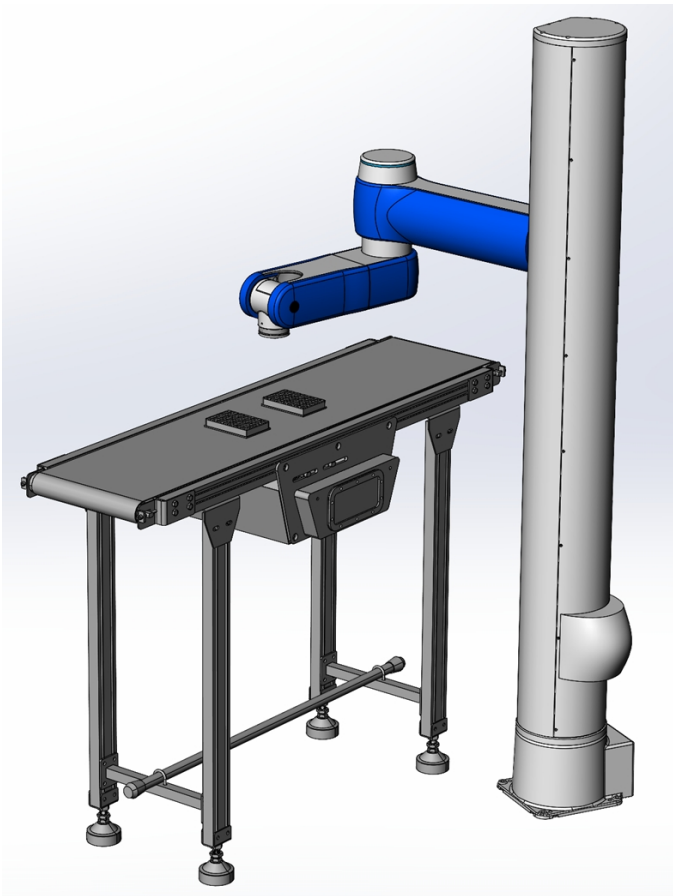

Contact Hazards and Measuring Points: Contact Hazard 1

Pinch of the Hand When Robot Approaches Workpiece on the Station

If a misaligned workpiece on the station is about to disturb the process, a human operator can try to correct the position of the workpiece by hand as the robot approaches it. This event of foreseeable misuse can lead to unintended contact with human. Since the robot approaches the workpiece slowly and the station constitutes an obstacle that hinders movement of the human body, the type of contact constitutes a pinch (load profile = quasi-static; spatial config = constrained).

Body regions that can be affected by the impact are lower arms and wrist joints and hands and fingers. Measurement method is a force sensor.

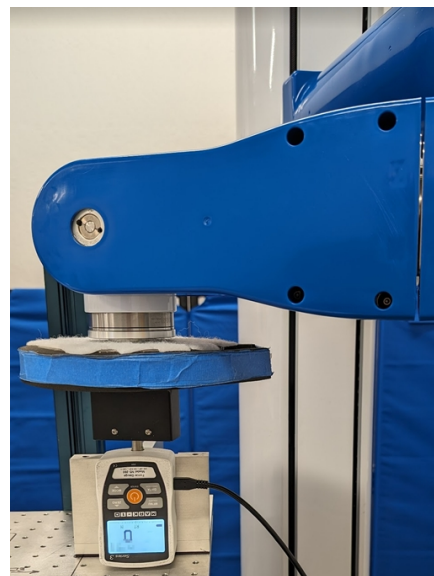
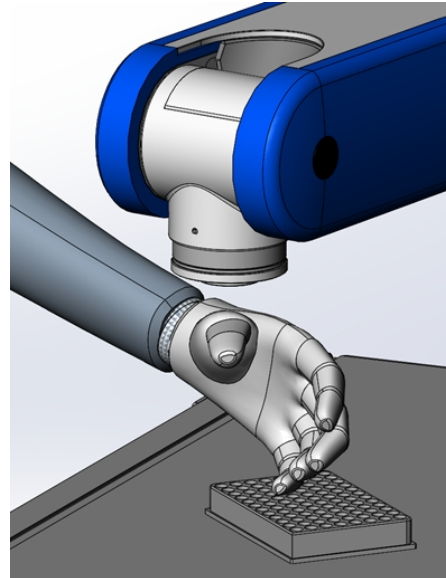
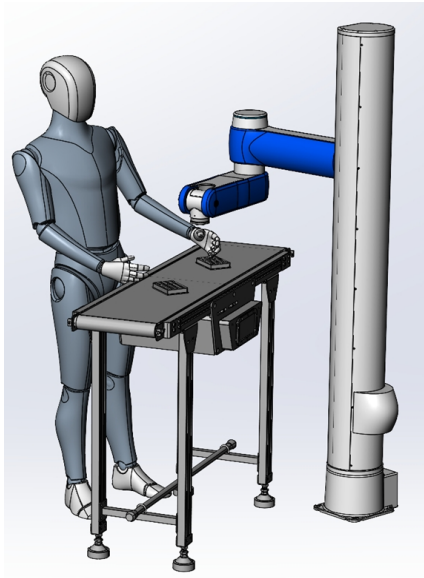

Possibly Endangered Body Locations

ID	Body Location	Force [N]		Contact type		
		QS	TR	Pinch	Impact	Crush
1	Lower arms and wrist joints	160 N	N/A	X	N/A	N/A
2	Hands and fingers	140 N	N/A	X	N/A	N/A

Measurement Results from Test of Body Location ID (1,2) – Height Detection Enabled.

Speed	Auto adjusted by Z-Height detect functionality
Payload	4 kg
Notes	Default settings / Z-Height detection enabled
Start position	XYZ(428,-200,1200,70, 180,-145)
End position	XYZ(428,-200,1106,70, 180,-145)
Impact Position	XYZ(428,-200,1086,70, 180,-145)
Distance after impact	20 mm
Motion profile	Auto adjusted by Z-Height detect functionality

Criteria 1 (quality indicator for the measurement setup; ISO/PAS 5672:2023, 7.4)

Contact Phase	Relative Standard Deviation For	~ [%]	Threshold	Measurement Setup
Quasi-static	Force [N]	1.43	5	OK
	Pressure [N/cm ²]	N/A	10	N/A
Transient	Force [N]	0.361	5	OK
	Pressure [N/cm ²]	N/A	10	N/A

Criteria 2 (Comparison of Sample Mean with the Biomechanical Limit for the Body Location Tested; ISO/PAS 5672:2023, 7.4)

Contact phase	Mean for	Units Measured (N)	Limit	Test
Quasi-static	Force [N]	118.33	140/160	Passed
	Pressure [N/cm2]	N/A	...	N/A
Transient	Force [N]	130.34	280/320	Passed
	Pressure [N/cm2]	N/A	...	N/A

Measurement Results from Test of Body Location ID (1,2) – Adjusted Negative Output Limit

Speed	10% (60 mm/sec)
Payload	4 kg
Notes	Adjusted negative output level for Z axis
Start Position	XYZ(428,-200,1200,70, 180,-145)
End Position	XYZ(428,-200,1106,70, 180,-145)
Impact Position	XYZ(428,-200,1086,70, 180,-145)
Distance After Impact	20 mm
Motion Profile	Accel/Decel: 100%/50% RampUp/RampDown: 0.15 InRange: 10 System Speed: 100%

Criteria 1 (Quality Indicator for the Measurement Setup; ISO/PAS 5672:2023, 7.4)

Contact Phase	Relative Standard Deviation for	~ [%]	Threshold	Measurement Setup
Quasi-static	Force [N]	0.70	5	OK
	Pressure [N/cm2]	N/A	10	N/A
Transient	Force [N]	N/A	5	N/A
	Pressure [N/cm2]	N/A	10	N/A

Criteria 2 (Comparison of Sample Mean with the Biomechanical Limit for the Body Location Tested; ISO/PAS 5672:2023, 7.4)

Contact Phase	Mean for	Units Measured (N)	Limit	Test
Quasi-static	Force [N]	133.34	140/160	Passed
	Pressure [N/cm ²]	N/A	...	N/A
Transient	Force [N]	N/A	N/A	N/A
	Pressure [N/cm ²]	N/A	...	N/A

Contact Hazards and Measuring Points: Contact Hazard 2

Impact with Upper Body Extremity When Robot Approaches Station Where Operator Task is Being Performed

A robot or operator drops a workpiece at the assembly/inspection station. The operator tries to remove it while the robot approaches the station with another part, leading to unintended contact with the operator’s shoulder, back, or upper arms. Since the human body can move freely (no obstacles near the station), the type of contact will constitute an impact (load profile = dynamic; special config = unconstrained).

Body locations that can be affected by the impact are back, shoulders, chest, upper arms, and elbow joints. The cell must be designed with a spatial configuration resulting in the human body being able to recoil at impact and being unconstrained. Robot lateral motion shall be at or below the shoulder level. Pinch and crush contact types are not considered for this contact hazard. Measurement method is a force sensor.

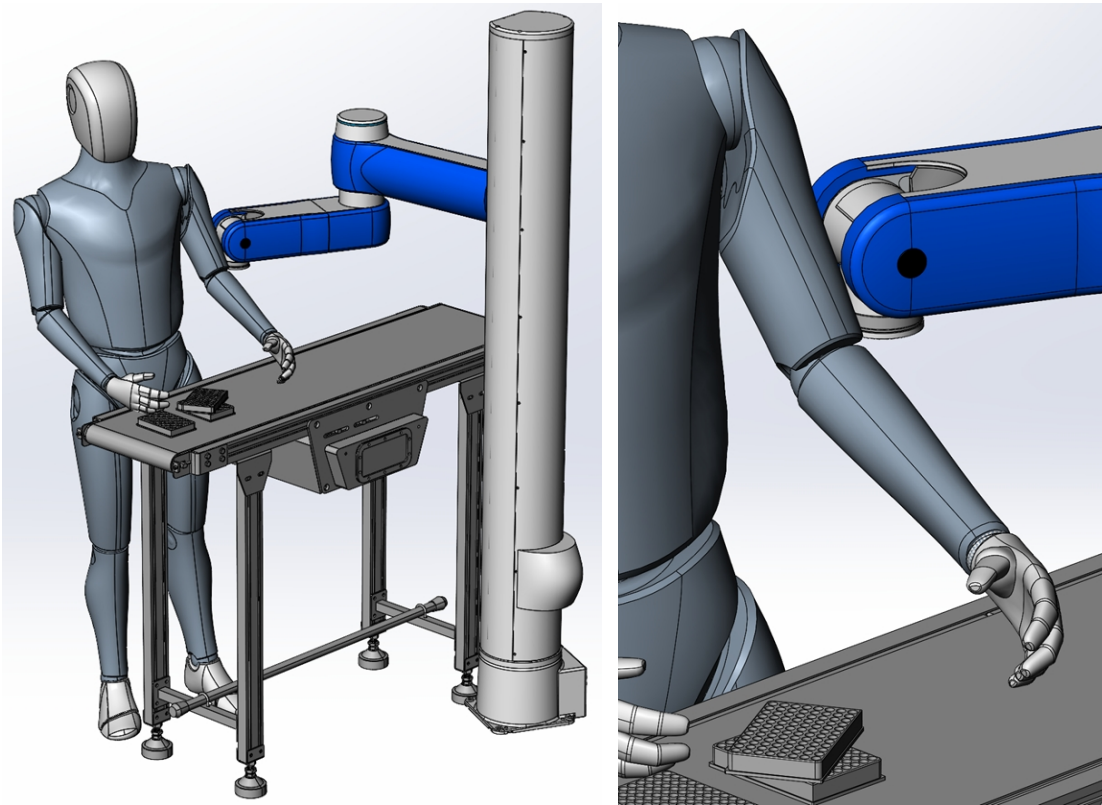

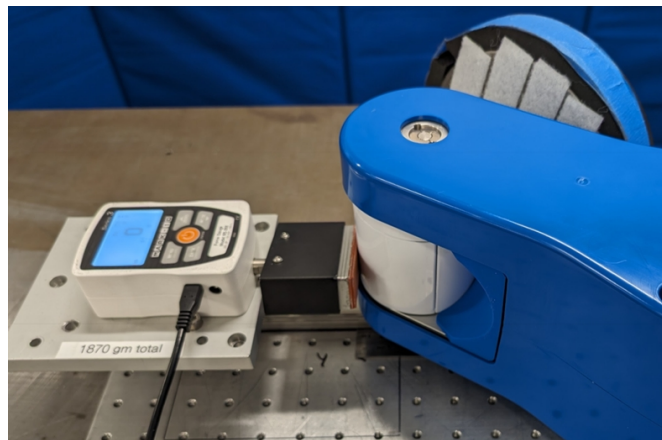
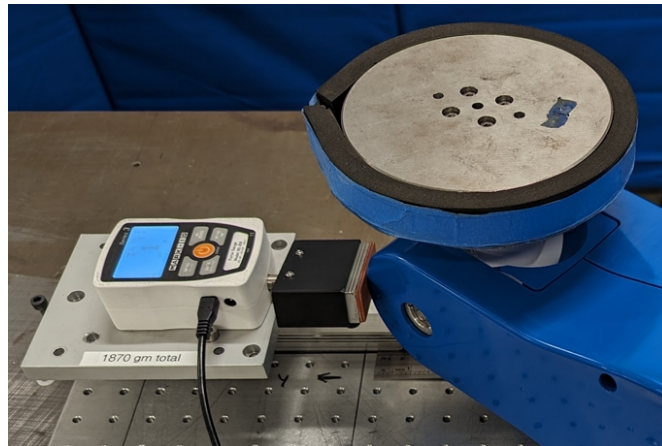

Possibly Endangered Body Locations

An X in one of the last three columns indicates the contact type that affects the associated body location.

ID	Body Location	Force [N]		Contact Type		
		QS	TR	Pinch	Impact	Crush
1	Back & shoulder	N/A	$F_T = 210 \times 2$	N/A	X	N/A
2	Chest	N/A	$F_T = 140 \times 2$	N/A	X	N/A
3	Upper arms & elbow joints	N/A	$F_T = 150 \times 2$	N/A	X	N/A

Measurement Results from Test of Body Location ID (1,2,3) – X Axis Cartesian Motion – Wrist Impact.

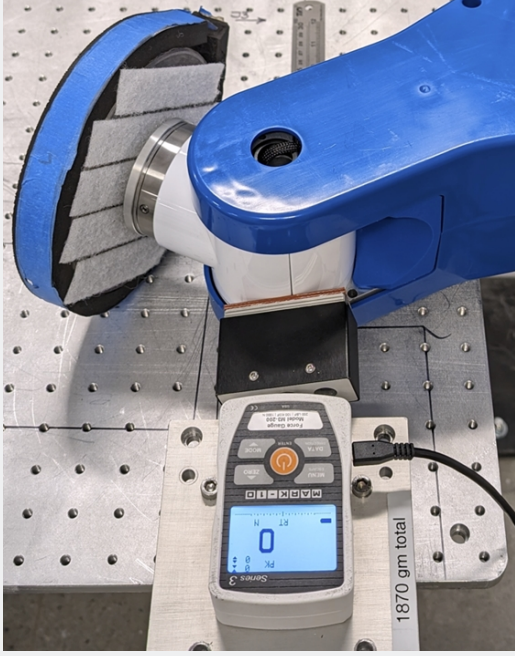
Speed	100% (600 mm/sec)
Payload	4 kg
Notes	X Axis Cartesian motion / Default settings
Start position	XYZ(400,-360,1024,-115,90,-50)
End position	XYZ.(660,-360,1024,-115,90,-50)
Impact Position	XYZ(610,-360,1024,-115,90,-50)
Distance after impact	50 mm
Motion profile	Accel/Decel: 100%/100% RampUp/RampDown: 0.15 InRange: 10 System Speed: 100%
Image	

Criteria 1 (Quality Indicator for the Measurement Setup; ISO/PAS 5672:2023, 7.4)

Contact phase	Relative standard deviation for	[%]	Threshold	Measurement Setup
Quasi-static	Force [N]	N/A	5	N/A
	Pressure [N/cm ²]	N/A	10	N/A
Transient	Force [N]	0.65	5	OK
	Pressure [N/cm ²]	N/A	10	N/A

Criteria 2 (Comparison of Sample Mean with the Biomechanical Limit for the Body Location Tested; ISO/PAS 5672:2023, 7.4)

Contact phase	Mean for	Units Measured (N)	Limit	Test
Quasi-static	Force [N]	N/A	N/A	N/A
	Pressure [N/cm ²]	N/A	...	N/A
Transient	Force [N]	125	280/300/420	Passed
	Pressure [N/cm ²]	N/A	...	N/A

Measurement Results from Test of Body Location ID (1,2,3) – X Axis Cartesian Motion – Cover Edge Impact.

Speed	100% (600 mm/sec)
Payload	4 kg
Notes	Y Axis Cartesian motion / Default settings
Start Position	XYZ(250,-250,1115,0,0,-70)
End Position	XYZ(730,-250,1115,0,0,-70)
Impact Position	XYZ(680,-250,1115,0,0,-70)
Distance after Impact	50 mm
Motion Profile	Accel/Decel: 100%/100% RampUp/RampDown: 0.15 InRange: 10 System Speed: 100%



Criteria 1 (Quality Indicator for the Measurement Setup; ISO/PAS 5672:2023, 7.4)

Contact Phase	Relative Standard Deviation for	[%]	Threshold	Measurement Setup
Quasi-Static	Force [N]	N/A	5	N/A
	Pressure [N/cm ²]	N/A	10	N/A
Transient	Force [N]	1.1	5	OK
	Pressure [N/cm ²]	N/A	10	N/A

Criteria 2 (Comparison of Sample Mean with the Biomechanical Limit for the Body Location Tested; ISO/PAS 5672:2023, 7.4)

Contact Phase	Mean for	Units Measured (N)	Limit	Test
Quasi-static	Force [N]	N/A	N/A	N/A
	Pressure [N/cm ²]	N/A	...	N/A
Transient	Force [N]	113.33	280/300/420	Passed
	Pressure [N/cm ²]	N/A	...	N/A

Measurement Results from Test of Body Location ID (1,2,3) – Y Axis Cartesian Motion – Wrist Impact.

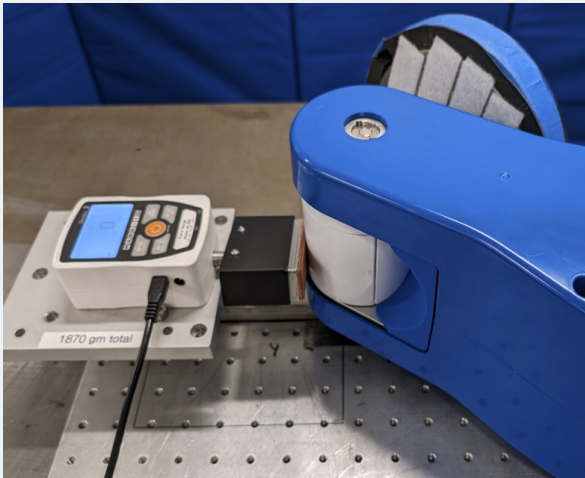
Speed	100% (600mm/sec)
Payload	4 kg
Notes	Y Axis Cartesian motion / Default settings
Start position	XYZ(140,-180,1025,135,90,-170)
End position	XYZ(140,-600,1025,135,90,-170)
Impact Position	XYZ(140,-550,1025,135,90,-170)
Distance after impact	50 mm
Motion profile	Accel/Decel: 100%/100% RampUp/RampDown: 0.15 InRange: 10 System Speed: 100%
Image	

Criteria 1 (Quality Indicator for the Measurement Setup; ISO/PAS 5672:2023, 7.4)

Contact phase	Relative standard deviation for	[%]	Threshold	Measurement Setup
Quasi-static	Force [N]	N/A	5	N/A
	Pressure [N/cm ²]	N/A	10	N/A
Transient	Force [N]	0	5	OK
	Pressure [N/cm ²]	N/A	10	N/A

Criteria 2 (Comparison of Sample Mean with the Biomechanical Limit for the Body Location Tested; ISO/PAS 5672:2023, 7.4)

Contact Phase	Mean for	Units Measured (N)	Limit	Test
Quasi-static	Force [N]	N/A	N/A	N/A
	Pressure [N/cm ²]	N/A	...	N/A
Transient	Force [N]	122	280/300/420	Passed
	Pressure [N/cm ²]	N/A	...	N/A

Measurement Results from Test of Body Location ID (1,2,3) – Y Axis Cartesian Motion – Cover Edge Impact.

Speed	100% (600 mm/sec)
Payload	4 kg
Notes	Y Axis Cartesian motion / Default settings
Start position	XYZ(215,-180,1115,40,0,-70)
End position	XYZ(215,-600,1115,40,0,-70)
Impact Position	XYZ(215,-550,1115,40,0,-70)
Distance after impact	50 mm

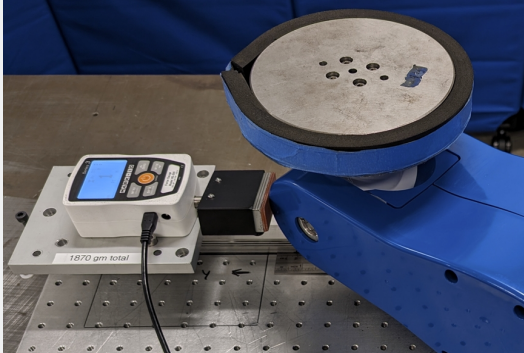
Motion profile	Accel/Decel: 100%/100% RampUp/RampDown: 0.15 InRange: 10 System Speed: 100%
Image	

Criteria 1 (Quality Indicator for the Measurement Setup; ISO/PAS 5672:2023, 7.4)

Contact Phase	Relative Standard Deviation for	[%]	Threshold	Measurement Setup
Quasi-static	Force [N]	N/A	5	N/A
	Pressure [N/cm ²]	N/A	10	N/A
Transient	Force [N]	0.40	5	OK
	Pressure [N/cm ²]	N/A	10	N/A

Criteria 2 (Comparison of Sample Mean with the Biomechanical Limit for the Body Location Tested; ISO/PAS 5672:2023, 7.4)

Contact Phase	Mean for	Units Measured (N)	Limit	Test
Quasi-static	Force [N]	N/A	N/A	N/A
	Pressure [N/cm ²]	N/A	...	N/A
Transient	Force [N]	117.67	280/300/420	Passed
	Pressure [N/cm ²]	N/A	...	N/A

NOTE: Weight of the pressure-force measurement devices (PFMD) used for the impact force testing is 1.9kg

Appendix N: Torque Values for Screws

Use these torque values for all screws and fasteners unless otherwise stated.

Torque Values in Newton-Meters

Screw Size M	Zinc	SS	Zinc	SS	Zinc	SS
	SHCS	SHCS	BHCS	BHCS	FHCS	FHCS
1.6	0.18	0.15	0.00	0.00	0.00	0.00
2	0.37	0.31	0.00	0.00	0.00	0.00
2.5	0.77	0.64	0.00	0.00	0.00	0.00
3	1.34	1.12	0.56	0.51	0.83	0.75
4	3.16	2.63	1.31	1.17	1.53	1.38
5	6.48	5.40	2.66	2.39	3.11	2.79
6	10.96	9.14	4.50	4.05	5.40	4.86

Appendix O: Conditions of Acceptability

For use only in (or with) complete equipment, when the acceptability of the combination is determined by UL Solutions. The following items should be evaluated to determine the acceptability for use in the end product:

- These devices shall be installed in compliance with the requirements for enclosure, mounting, electrical spacing, and segregation of the end-use equipment.
- The power supply and drives in this report have been evaluated as a system and they shall be installed accordingly. The suitability of any other installation manner shall be determined in the end product application.
- The front face has not been evaluated as an ultimate or part of the overall enclosure.
- Wait 7 minutes after removal of power before servicing equipment for the system capacitance to discharge below a 50 VDC level.
- The input and output connectors are suitable for factory wiring only.
- The spacings have been evaluated to Pollution Degree 2.
- These devices are intended for installation in a Pollution Degree 2 environment.
- These models are suitable for operation in a surrounding air temperature of 40°C.
- This system, power supply and motor drives, are suitable for use on a circuit capable of delivering not more than 1,500 rms symmetrical amperes, 250 VAC maximum.
- The Motor Drive Series 6000 shall be provided with complete instructions as to how to replace the battery cell ending with the statement: "Dispose of used cell promptly. Keep away from children. Do not disassemble and do not dispose of in fire."
- Peak currents indicated in the nomenclature are temporary over-currents only, not intended for use as continuous ratings.